Electronic Thesis and Dissertation Repository

8-18-2015 12:00 AM

Mechanistic Studies of Donor-Acceptor Cyclopropanes

Tristan Chidley
The University of Western Ontario

Supervisor
Brian L. Pagenkopf
The University of Western Ontario

Graduate Program in Chemistry
A thesis submitted in partial fulfillment of the requirements for the degree in Master of Science
© Tristan Chidley 2015

Follow this and additional works at: <https://ir.lib.uwo.ca/etd>

 Part of the [Organic Chemistry Commons](#)

Recommended Citation

Chidley, Tristan, "Mechanistic Studies of Donor-Acceptor Cyclopropanes" (2015). *Electronic Thesis and Dissertation Repository*. 3284.
<https://ir.lib.uwo.ca/etd/3284>

This Dissertation/Thesis is brought to you for free and open access by Scholarship@Western. It has been accepted for inclusion in Electronic Thesis and Dissertation Repository by an authorized administrator of Scholarship@Western. For more information, please contact wlsadmin@uwo.ca.

Mechanistic Studies of Donor-Acceptor Cyclopropanes

(Thesis Format: Monograph)

by

Tristan Chidley

Graduate Program in Chemistry

A thesis submitted in partial fulfillment
of the requirements for the degree of
Master of Science

School of Graduate and Postdoctoral Studies
The University of Western Ontario
London, Ontario, Canada

© Tristan Chidley 2015

Abstract and Keywords

Cyclopropane 1,1-diesters have been investigated as a source of donor-acceptor cyclopropanes, providing an understanding of the mechanism of reaction between these cyclopropanes and nitrosoarenes, as well as azo dicarboxylates. Cross-over experiments have been utilized to provide key pieces of experimental evidence that help generate a theoretical model of the reactions. By understanding these reactions with precision, the avenue to expand the reaction scope and develop other useful reactions is opened up. This allows the chemistry to be better utilized, providing easier access to important molecules when needed, and contributes to advancing the field of synthetic organic chemistry.

In addition, cyclobutane 1,1-diesters were also investigated as a source of donor-acceptor cyclobutanes. Specifically, their use in cycloaddition reactions has been developed to include the reaction of cyclobutanes with *cis*-diazenes, providing access to hexahydropyridazines. These compounds are synthesized in an efficient manner and are known to contain biologically active properties.

Keywords: donor-acceptor cyclopropane, donor-acceptor cyclobutane, cyclopropane, cyclobutane, tetrahydro-1,2-oxazine

For my parents, Ray and Dianne

Acknowledgements

I would like to acknowledge Dr. Brian L. Pagenkopf for accepting me into his research group, for which I am extremely grateful. I am also thankful to all the students who have worked, and are still working in the Pagenkopf group, especially Naresh Vemula for giving me valuable advice, interesting research ideas, and being a great friend. I would also like to thank Dr. Michael A. Kerr and the Kerr group for interesting research discussions during our shared super group meetings. Dr. Matthew Williams helped with NMR analysis, and Doug Hairsine helped with mass spectrometry and GC-MS data. I would finally like to thank Western University for financial support as a graduate student in the Chemistry Department.

During my time at Western University I had an enjoyable experience taking graduate level classes, which were extremely helpful in advancing my theoretical knowledge in the field of organic chemistry. I was grateful to have enthusiastic professors such as Dr. Hudson who taught me a deeper understanding of mechanisms, and Dr. Kerr who taught me heterocyclic chemistry and total synthesis.

I would like to thank my family for their unconditional love and support throughout my life and throughout my time at the University of Western Ontario. They have contributed so much to my life and I am happy to give back by dedicating this thesis to them.

Table of Contents

Abstract and Keywords	ii
Dedication	iii
Acknowledgments	iv
List of Schemes	vii
List of Figures	viii
List of Tables	ix
Abbreviations	x
Chapter 1 - General Introduction	1
1.1 Introduction	2
1.1.1 Donor-Acceptor (DA) Cyclopropanes	3
1.1.2 Cycloadditions of DA Cyclopropanes	4
1.1.3 Cycloadditions of DA Cyclopropanes with Nitrones	5
1.1.4 Tetrahydro-1,2-Oxazines	9
Chapter 2 - Cycloadditions of Donor-Acceptor Cyclopropanes with Nitrosoarenes	11
2.1 Introduction	11
2.1.1 Cycloadditions of DA Cyclopropanes with Nitrosoarenes	11
2.2 Results and Discussion	12
2.2.1 Synthesis of DA Cyclopropanes	16
2.2.2 Cross-Over Experiment #1	17
2.2.3 Reaction Scope	19
2.3 Experimental	22
2.4 Supporting Information	23

Chapter 3 - Cycloadditions of Donor-Acceptor Cyclopropanes with Azo Dicarboxylates ...	32
3.1 Introduction	32
3.2 Cycloadditions of DA Cyclopropanes with <i>trans</i> -Diazenes	32
3.2.1 Cross-Over Experiment #2	33
3.3 Cycloadditions of DA Cyclopropanes with <i>cis</i> -Diazenes	34
3.3.1 Cross-Over Experiment #3	38
3.3.2 Cross-Over Experiment #3 Reversed	41
3.4 Experimental	44
3.5 Supporting Information	45
Chapter 4 - Cycloadditions of Donor-Acceptor Cyclobutanes with <i>cis</i>-Diazenes	53
4.1 Introduction	53
4.1.1 Alkoxy-Activated Cyclobutane Diesters	54
4.1.2 Synthesis of DA Cyclobutanes	55
4.1.3 Cycloadditions of DA Cyclobutanes with <i>cis</i> -Diazenes	55
4.2 Results and Discussion	56
4.2.1 Reaction Scope	58
4.3 Post Modification of Hexahydropyridazine Products	59
4.4 Experimental	60
4.5 Supporting Information	61
Chapter 5 - Conclusions	65
References	66
Appendix 1 - NMR Data Chapter 2	68
Appendix 2 - NMR Data Chapter 3	85
Appendix 3 - NMR Data Chapter 4	99
Appendix 4 - GC-MS Data Chapter 2	105

Appendix 5 - GC-MS Data Chapter 3	111
Curriculum Vitae	126

List of Schemes

Scheme 1.1 General reactions of DA cyclopropanes	4
Scheme 1.2 Cycloaddition of nitrones with α,β -unsaturated systems and cyclopropanes	5
Scheme 1.3 Homo [3+2] cycloaddition of nitrones with DA cyclopropanes	6
Scheme 1.4 Mechanism of cycloaddition of DA cyclopropanes with nitrones	7
Scheme 1.5 Three-component homo [3+2] cycloaddition	7
Scheme 1.6 Mechanism studies on cycloadditions of DA cyclopropanes with nitrones	8
Scheme 2.1 [3+2] Cycloaddition of DA cyclopropanes with nitrosoarenes	11
Scheme 2.2 Reaction of DA cyclopropane with nitrosoarene	13
Scheme 2.3 Three component synthesis of tetrahydro-1,2-oxazine	14
Scheme 2.4 Proposed mechanism for the reaction of DA cyclopropanes with nitrosoarenes ...	16
Scheme 2.5 Cross-over experiment for the reaction of DA cyclopropanes with nitrosoarenes ..	19
Scheme 3.1 Cycloaddition of DA cyclopropanes with azo dicarboxylates	32
Scheme 3.2 Cycloaddition of DA cyclopropanes with <i>trans</i> -diazenes	33
Scheme 3.3 Cross-over experiment of DA cyclopropanes with <i>trans</i> -diazenes	34
Scheme 3.4 Cycloaddition of DA cyclopropanes with <i>cis</i> -diazenes	34
Scheme 3.5 Synthesis of PTAD	35
Scheme 3.6 Proposed mechanism for the formation of minor product 50a	36

Scheme 3.7 Proposed mechanism for the formation of major product 51a	36
Scheme 3.8 Formation of the two different pyrazolidine <i>regio</i> -isomers	37
Scheme 3.9 Cross-over experiment of DA cyclopropanes with <i>cis</i> -diazenes	38
Scheme 3.10 Reversed cross-over experiment of DA cyclopropanes with <i>cis</i> -diazenes	42
Scheme 3.11 Reaction of nitrosoarenes and <i>cis</i> -diazenes with DA cyclopropanes	43
Scheme 3.12 Mechanistic formation of 1,3-dipoles	43
Scheme 4.1 Reactivity of DA cyclobutanes	53
Scheme 4.2 Cycloaddition of DA cyclobutane with aldehydes or ketones	53
Scheme 4.3 Pagenkopf research of DA cyclobutanes	54
Scheme 4.4 Two-step synthesis of DA cyclobutanes	55
Scheme 4.5 General cycloaddition of DA cyclobutanes with <i>cis</i> -diazenes	56
Scheme 4.6 Cycloaddition of DA cyclobutanes with PTAD	56
Scheme 4.7 Potential post modifications of hexahydropyridazine 74b	59

List of Figures

Figure 1.1 Strain energies of small carbocycles	2
Figure 1.2 Examples of biologically active compounds containing a cyclopropane ring	3
Figure 1.3 Tetrahydro-1,2-oxazine motif in natural and synthetic compounds	9
Figure 2.1 Catalytic cycle of [3+2] cycloaddition of DA cyclopropanes with nitrosoarenes	12
Figure 2.2 ¹ H NMR of tetrahydro-1,2-oxazine 35a	13
Figure 2.3 ¹ H NMR of tetrahydro-1,2-oxazine 35a prepared from Kerr's method	14

Figure 3.1 Proposed mechanism for the cycloaddition of DA cyclopropane with <i>cis</i> -diazene ..	35
Figure 3.2 Expected products from the cross-over experiment	39
Figure 3.3 Proposed cross-over based products from the cross-over experiment	39
Figure 3.4 Results of cross-over experiment #3	41
Figure 3.5 Results of reversed cross-over experiment #3	42
Figure 4.1 Crystal structure of hexahydropyridazine 74c	57
Figure 4.2 Cycloadditions of different DA cyclobutanes with PTAD	58

List of Tables

Table 2.1 Optimization of Yb(OTf) ₃ catalyzed reaction of DA cyclopropanes with nitrosoarene	15
Table 2.2 Synthesis of DA cyclopropanes	17
Table 2.3 Synthesis of tetrahydro-1,2-oxazine standards	18
Table 2.4 Reaction scope with different nitrosoarenes	20
Table 2.5 Reaction scope with different DA cyclopropanes	21
Table 3.1 Cycloaddition of DA cyclopropanes with <i>trans</i> -diazenes	33
Table 3.2 Synthesis of pyrazolidine standards	40
Table 4.1 Cycloaddition of DA cyclobutane with <i>cis</i> -diazene	57

Abbreviations

A = Acceptor

Ac = Acetyl

Ar = Aryl

Boc = *tert*-butyloxycarbonyl

D = Donor

d = doublet

dd = doublet of doublets

DA = Donor-Acceptor

DCE = Dichloroethane

DCM = Dichloromethane

DMF = Dimethylformamide

DMSO = Dimethyl Sulfoxide

E = Electrophile

EDG = Electron Donating Group

EWG = Electron Withdrawing Group

GC-MS = Gas Chromatography-Mass Spectrometry

HPLC = High-Performance Liquid Chromatography

HRMS = High-Resolution Mass Spectra

m = multiplet

NMR = Nuclear Magnetic Resonance

Nu = Nucleophile

OTf = Trifluoromethanesulfonate

Ph = Phenyl

ppm = parts per million

ⁱPr = iso-propyl

PTAD = 4-Phenyl-1,2,4-triazoline-3,5-dione

q = quartet

rt = Room Temperature

R_f = Retention Factor

s = singlet

t = triplet

td = triplet of doublets

TLC = Thin Layer Chromatography

Chapter 1 - General Introduction

The use of cyclopropanes and cyclobutanes in synthetic organic chemistry has received a considerable amount of attention over the years, with multiple applications being continually developed. This chapter serves as an introduction to the chemistry of donor-acceptor (DA) cyclopropanes and cyclobutanes, and their utilization in the synthesis of heterocyclic ring systems. The focus of the reactions is on the use of 1,1-cyclopropanediester as a source of DA cyclopropanes. The work presented in this thesis was done entirely by me, and the information acquired will be published in peer-reviewed journals in the near future.

Chapter two investigated the reaction of DA cyclopropanes with nitrosoarenes with the use of a cross-over experiment to acquire key experimental data that were used to validate a potential reaction mechanism. The chemistry of DA cyclopropanes with nitrones is well known, but similar products were produced when the nitrone was switched with a nitroso functional group, so a complete mechanism would be valuable for not only understanding this reaction, but in the development of new reactions to come when utilizing DA cyclopropanes.

Chapter three investigated the reaction of DA cyclopropanes with both *cis* and *trans* azo dicarboxylates. The chemistry behind the unusual ring opening reaction of DA cyclopropanes with specifically *cis*-diazenes was a key component of this chapter. The use of cross-over experiments was used to gain a deeper understanding into these reactions and resulted in a new pattern of reactivity which showed similarities to the chemistry presented in chapter two as well.

Chapter four investigated the use of DA cyclobutanes in a new cycloaddition reaction with *cis* azo dicarboxylates. It was shown that DA cyclobutanes are able to react with *cis*-diazenes and form hexahydropyridazines ring systems which are a rare type of heterocycle, which have only a limited number of synthetic procedures available.

The chemistry learned throughout these chapters has shown new procedures to construct heterocyclic compounds from DA cyclopropanes and cyclobutanes, and answer mechanistically related questions into how these compounds form. These experimental observations have shown repeating patterns of reactivity that potentially could be adjusted to include the incorporation of new elements, and hopefully help in the discovery or design of new reactions.

1.1 Introduction

Cyclopropanes and cyclobutanes have been shown to play an important and useful role in synthetic organic chemistry with an array of various reaction partners.¹ Comparison of the properties of carbocycles show cyclopropane and cyclobutane to have a higher ring strain energy due to the distortion of the bond angles away from the ideal 109° angle of the tetrahedron. Figure 1.1 describes the higher ring strain energy of cyclic compounds when the carbon-carbon bond angles in cyclopropane (**1**) and cyclobutane (**2**) are not able to adopt an ideal conformation such as the lower energy chair form of cyclohexane (**4**).² When smaller carbocycles are prepared, their inherent ring strain functions as a built-in energy source which can be used as a driving force to produce compounds with various uses in chemical synthesis. The unique properties of cyclopropanes allow for a very useful activation of sp^3 C-C bonds within the cycle, which has contributed to an array of different reaction types. These properties are also useful in biological settings with many cyclopropane ring-opening reactions occurring in nature.

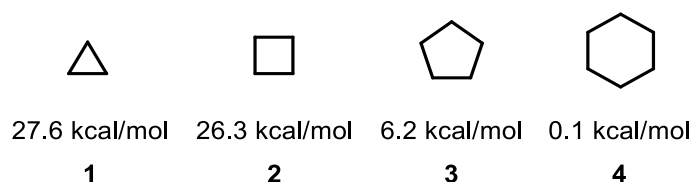

Figure 1.1 Strain energies of small carbocycles

Cyclopropanes are found in natural products and biological settings, including lipids, pheromones, terpenes, and steroids.³ Examples include the anti-HIV drug Nevirapine (**5**), and the potent antibiotics Ciprofloxacin (**6**) and Vigamox (**7**) as seen in Figure 1.2. Vigamox was ranked in the top 200 brand-name drugs by U.S. retail dollars in 2010 with a profit that year of \$0.25 billion.⁴

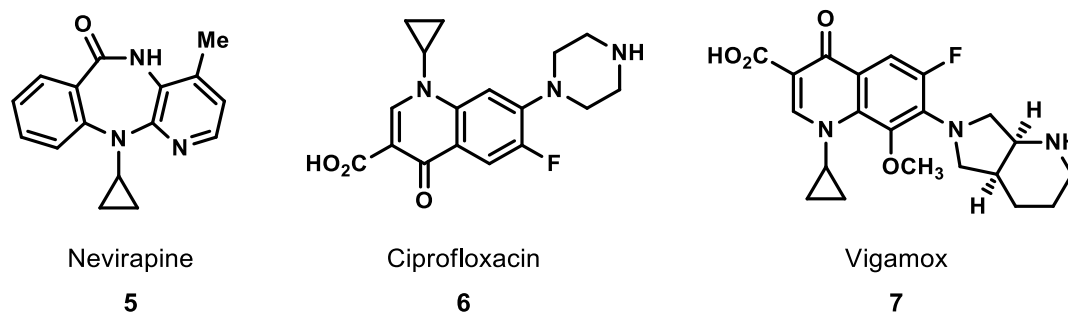

Figure 1.2 Examples of biologically active compounds containing a cyclopropane ring

Cyclopropanes have had many uses in synthetic chemistry, such as in total synthesis, and in the preparation of many useful compounds. In order to make use of the cyclopropane ring and control which bonds will break to undergo reaction, activating groups are strategically used. The cyclopropane ring is reactive due to its high ring strain, but activating groups are commonly present on the ring to selectively increase, and control reactivity. The effects of activating groups can also be enhanced or activated using thermal or catalytic conditions.

1.1.1 Donor-Acceptor (DA) Cyclopropanes

Increased reactivity can be achieved when donor and acceptor groups are arranged in a *vicinal* relationship on the carbocycle to activate the bond between the two groups and allow for different reaction types.⁵ Common examples of electron donating groups (EDG) include: alkoxy, amino, aryl, vinyl, and other groups that can stabilize carbocations. Examples of electron withdrawing groups (EWG) commonly include: esters, carbonyls, and other groups that can stabilize carbanions.⁶

Activation of donor-acceptor (DA) cyclopropanes (**8**) and cyclobutanes with Lewis acids allow formation of 1,3-dipole (**9**) and 1,4-dipole intermediates, respectively. Scheme 1.1 shows how DA cyclopropanes are able to react with various electrophiles, nucleophiles, or dipolarophiles.

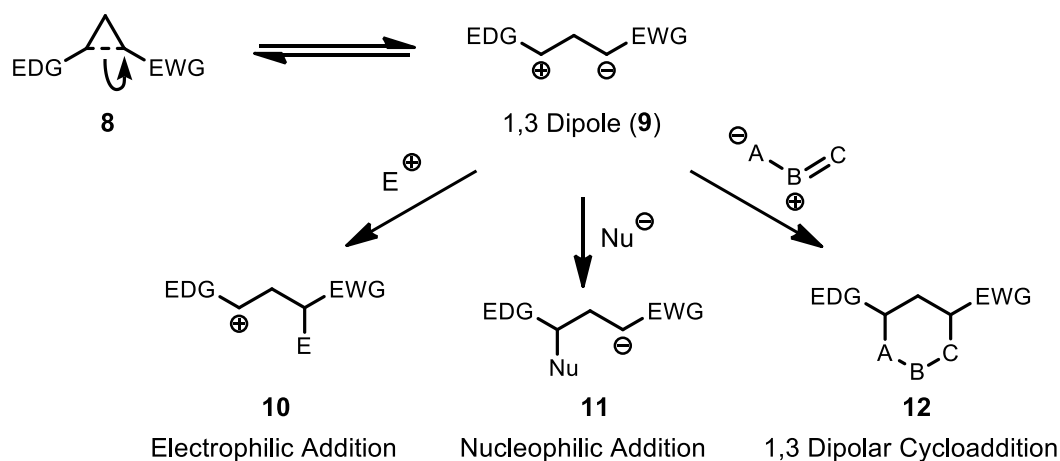

Scheme 1.1 General reactions of DA cyclopropanes

DA cyclopropanes have been extensively studied over the last 50 years and serve as a synthetically useful 1,3 carbon dipolarophile. This allows for multiple applications such as serving as starting materials for the synthesis of highly substituted 5- and 6-membered carbocycles and heterocycles via annulation (cycloaddition) reactions.

1.1.2 Cycloadditions of DA Cyclopropanes

Cycloaddition chemistry has the ability to produce a wide range of molecular architecture often with high levels of control and efficiency.⁷ Cycloadditions have also proven to be an effective method for the construction of heterocyclic compounds. The ability to efficiently access different heterocyclic motifs has great importance because of the interesting biological activities that are often associated with the systems when found in living organisms. Active heterocycles have shown considerable biological actions, such as antifungal, anti-inflammatory, antibacterial, anticonvulsant, anti-allergic, herbicidal, anticancer activity.⁸ A main focus of this thesis is on cycloadditions of DA cyclopropanes with different dipolarophiles, and understanding their mechanism of action in the creation of heterocyclic compounds.

Cycloadditions belong to a broader class of reactions known as pericyclic reactions. Pericyclic reactions are often characterized by a simultaneous event of bond breaking and bond creating in the reaction process. This attribute often provides a way of controlling the

stereochemistry for a specific reaction. In some cases, the stereochemistry of the starting material can control the stereochemical outcome of the product. This type of prediction is made more accurately when a complete understanding of the reaction mechanism and transition states are known.

Typical cycloadditions often occur through tightly held or compact transition states which is governed by maximum orbital overlap between reaction partners.⁹ These so-called “closed” transition states are powerful tools in the asymmetric synthesis field for analyzing enantioselective and diastereo-selective reactions. Acquiring accurate models of transition states is therefore of utmost importance in the understanding of stereo-selective reactions. In addition to understanding transition states, it may also be of equal importance to understand the overall mechanism of a reaction.

DA cyclopropanes, such as 1,1-cyclopropane diesters react in a similar way to alkenes substituted with an electron withdrawing group (EWG), such as α,β -unsaturated carbonyl systems.¹⁰ The difference is the additional carbon in the cyclopropane ring, which makes the reaction a one carbon homologation as seen in the [3+2], and homo [3+2] cycloaddition (Scheme 1.2).

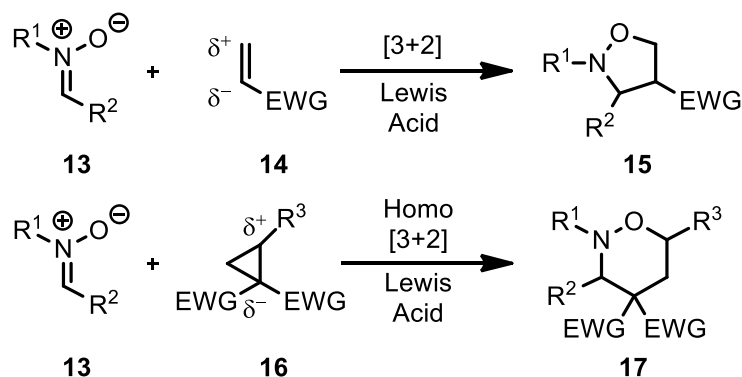

Scheme 1.2 Cycloaddition of nitrones with α,β -unsaturated systems and cyclopropanes

1.1.3 Cycloadditions of DA Cyclopropanes with Nitrones

Nitrones (**13**) have been shown to react with 1,1-cyclopropane diesters (**18**) in the presence of $\text{Yb}(\text{OTf})_3$ to yield tetrahydro-1,2-oxazines (**19**) with a high degree of regio- and stereo-control, as seen in scheme 1.3.¹¹

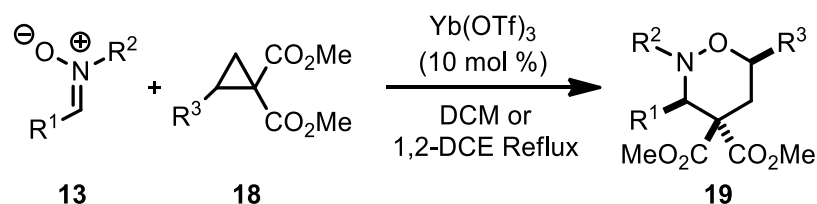

Scheme 1.3 Homo [3+2] cycloaddition of nitrones with DA cyclopropanes

Single-crystal X-Ray analysis has shown that the observed product always forms a single diastereomer in which the substituents at the C3 and C6 position are always in a *cis* relationship. This type of transformation is an example of a dipolar homo [3+2] cycloaddition, but is also considered a 1,3-dipolar cycloaddition, and was first reported by the Kerr group in 2003. Mechanistic studies have been carried out with quantum chemical DFT calculations and indicate that two very similar, but distinct, reaction pathways may account for the transformation, and can be seen in Scheme 1.4.¹² One pathway is an asynchronous concerted mechanism that involves an approximate half-chair-like transition state where the oxygen of the nitrone leads the attack on the cyclopropane ring (**I**). The second pathway is a stepwise mechanism which involves a zwitterionic imminium intermediate, with the oxygen of the nitrone again leading the attack on the cyclopropane ring (**II**). Understanding this transformation in detail has helped discover another transformation, where DA cyclopropanes are capable of reacting with nitrosoarenes.

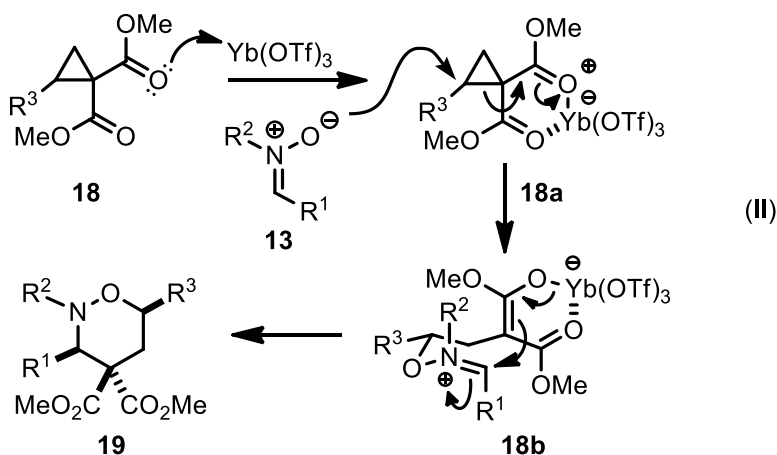
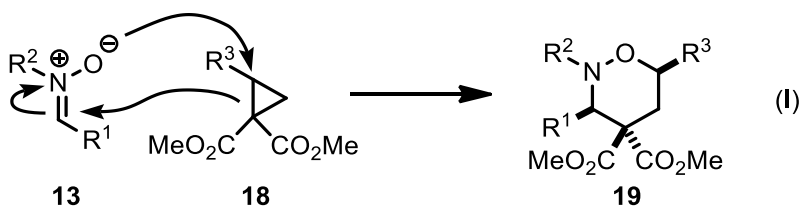

Scheme 1.4 Mechanism of cycloaddition of DA cyclopropanes with nitrones

In 2004 the Kerr group showed that this reaction could be carried out using a three-component coupling strategy between an aldehyde (**21**) and a hydroxylamine (**20**) as seen in Scheme 1.5. In this strategy, the nitron (**13**) is formed *in situ*, which is useful when dealing with nitrones that are difficult to prepare or are unstable due to oligomerization under the required Lewis acidic conditions.¹³

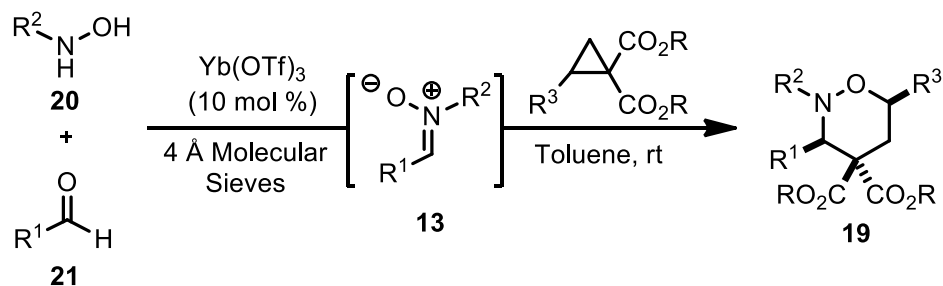

Scheme 1.5 Three-component homo [3+2] cycloaddition

In order to address the issue as to whether this reaction mechanism is going through a concerted or step-wise pathway, extensive studies were performed using enantio-pure starting materials. Therefore the reaction of enantiomerically enriched 3-methyl-2-phenylcyclopropane-1,1-dicarboxylates with nitrones was performed by Dr. Michael Kerr in 2007¹⁴, as shown in scheme 1.6.

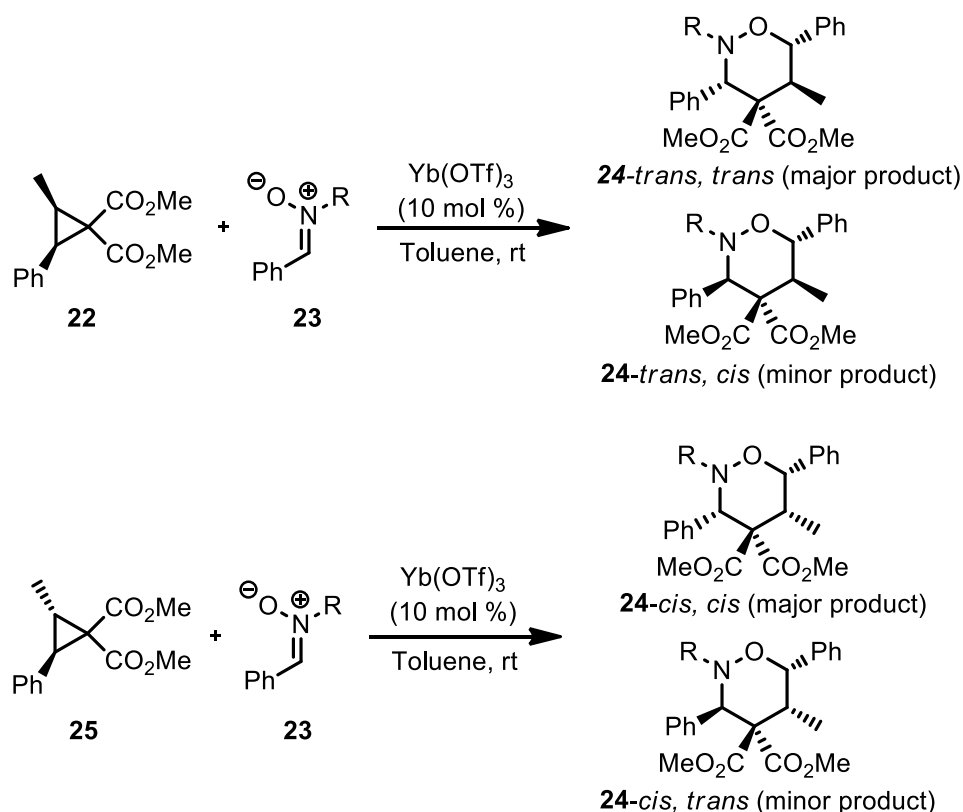

Scheme 1.6 Mechanism studies on cycloadditions of DA cyclopropanes with nitrones

A key piece of information discovered in this study is the inversion of stereochemistry at C2 for both *cis* and *trans* diastereomers of the starting material. The results provided experimental evidence that supports the idea of a step-wise pathway and not a concerted pathway. In the step-wise pathway, there is an inversion of stereochemistry when the oxygen from the nitrone acts as a nucleophile and opens the cyclopropane ring.

Experimental evidence that also helps support the mechanism proposed by Dr. Michael Kerr was provided when optically active cyclopropanes were reacted with nitrones in the presence

of a catalytic amount of $\text{Ni}(\text{ClO}_4)_2$ without a chiral ligand to give the tetrahydro-1,2-oxazine in a high yield with the same level of enantiomeric purity as that of the starting material.¹⁵

This work by Tang *et al* shows how understanding the proposed mechanism of a reaction can lead to other discoveries, in this case, applications for kinetic resolution was developed. This was made possible because of the diligent mechanistic studies performed by Dr. Michael Kerr to understand the reaction with a high level of understanding.

1.1.4 Tetrahydro-1,2-Oxazines

The tetrahydro-1,2-oxazine motif is rarely found in nature, appearing in only a small number of natural products. Examples of these natural products include FR900482 (**27**) and FR66979 (**28**) as seen in Figure 1.3, which exhibit antitumor and antibiotic properties.¹⁶ Both of these natural products are structurally similar to the mitomycins, including mitomycin C, which has been in widespread clinical use for more than 20 years. The biological activities of FR900482 and FR66979 are also similar to the mitomycins, which are both reductively activated *in vivo* and covalently cross-link DNA in a fashion analogous to the mitomycins. The difference in structures that ultimately causes a different mechanism of bio-reductive activation between the mitomycins and FR900482, cause FR900482 to not exhibit oxidative strand scission of DNA and to not produce a superoxide radical anion during activation. The FR900482 class of compounds represents a compelling clinical replacement for mitomycin C, given its greatly reduced host toxicity and superior DNA interstrand cross-linking efficacy.

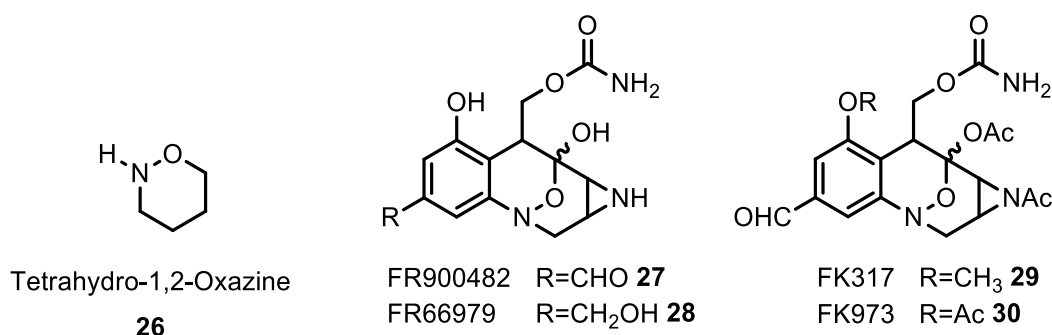

Figure 1.3 Tetrahydro-1,2-oxazine motif in natural and synthetic compounds

FK317 (**29**) and FK973 (**30**) are synthetic analogs of the natural products FR900482 and FR66979, and also contain the tetrahydro-1,2-oxazine system. The antitumor activity of FK317 was found to be equivalent to, or stronger than cisplatin, mitomycin C, and Taxol. Because of compounds such as FR900482 and FR66979 which contain the tetrahydro-1,2-oxazine system and show interesting biological features, new synthetic routes to the tetrahydro-1,2-oxazine core are useful because of the limited ways in which these systems can be created. These limitations have made the tetrahydro-1,2-oxazine ring difficult to synthesize in the past, so having the ability to form the system in a controlled manner is definitely beneficial to the synthetic community. This project looks at how cycloaddition chemistry can be utilized as an effective method for heterocyclic ring construction, and how understanding the process mechanistically may lead to the discovery of other reaction types. It is already known that DA cyclopropanes react with nitrones to form the tetrahydro-1,2-oxazine ring, and a goal of this project is to discover other partners that are compatible with DA cyclopropanes to form these systems as well as other interesting heterocycles.

The post modification of tetrahydro-1,2-oxazines has been examined by Dr. Michael Kerr and has led to some interesting and important uses for the ring system. Selective N-O cleavage of the tetrahydro-1,2-oxazine ring has been utilized in the synthesis of amino alcohols. The amino alcohols have then been used to construct pyrrolidines which has applications in the total synthesis of Nakadomarin A for example.¹⁷ Pyrrole synthesis has also emerged as a tool made possible from post modification of the ring system.¹⁸ These useful applications showcase how important these molecules are, and how important it is to obtain these compounds in an efficient and controllable manner.

Chapter 2 - Cycloadditions of Donor-Acceptor Cyclopropanes with Nitrosoarenes

2.1 Introduction

Nitrosoarenes have been coupled with DA cyclopropanes in the synthesis of various heterocyclic ring systems.¹⁹ Although reactions of nitrosoarenes and DA cyclopropanes have been reported, their potential has still yet to be reached. The discovery of new reactions utilizing the nitroso functional group is still ongoing and demonstrates the versatility in the construction of heterocyclic systems. The nitrogen-oxygen single bond that forms when nitrosoarenes are used in ring construction, has been shown to be a site of functionalization for the production of important molecules such as amino alcohols.²⁰

2.1.1 Cycloadditions of DA Cyclopropanes with Nitrosoarenes

Previous research in the Studer group²¹ has shown DA cyclopropanes to be a compatible reaction partner with nitrosoarenes, which undergo a [3+2] cycloaddition forming isoxazolidines when catalyzed with MgBr₂ as seen in scheme 2.1. The successful use of DA cyclopropanes with nitrosoarenes in cycloaddition reactions encouraged the Pagenkopf group to determine if these reaction partners were able to undergo other transformations.

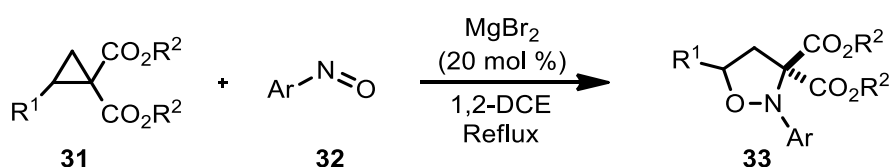

Scheme 2.1 [3+2] Cycloaddition of DA cyclopropanes with nitrosoarenes

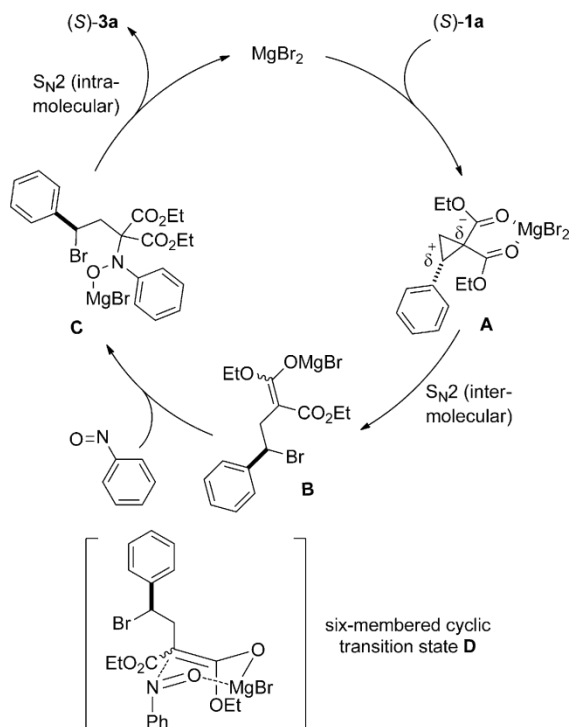

Figure 2.1 Catalytic cycle of [3+2] cycloaddition of DA cyclopropanes with nitrosoarenes

The mechanism (Figure 2.1) shows a bromide ion attacking and opening the cyclopropane ring, which drew my attention because of the Pagenkopf group's interest in $\text{Yb}(\text{OTf})_3$ catalyzed DA cyclopropane cycloaddition chemistry. Under $\text{Yb}(\text{OTf})_3$ catalytic conditions, only the triflate ion would be present as a counter-ion and would presumably be less nucleophilic towards the cyclopropane, allowing the nitrosoarene a chance to act as the nucleophile and perhaps open the cyclopropane ring in a [3+2] annulation to yield an isooxazolidinone. The initial hope was in opening of the DA cyclopropane in a manner that would yield the opposite *regio*-isomer as the Studer group. Instead of observing an isooxazolidinone, a tetrahydro-1,2-oxazine motif was formed.

2.2 Results and Discussion

Interestingly, it was discovered that when nitrosoarenes were allowed to react with DA cyclopropanes, the tetrahydro-1,2-oxazine motif was formed when catalyzed with $\text{Yb}(\text{OTf})_3$ under refluxing conditions. The observed *cis* stereochemical outcome of the tetrahydro-1,2-oxazine ring

is consistent with Kerr's reaction of DA cyclopropanes with nitrones. A nitron intermediate may account for the formation of the tetrahydro-1,2-oxazine system. This assumption was backed up by experimental evidence when considering the yield of the reaction. When both starting materials were used in a 1:1 ratio of equivalents, a yield of 44% was observed (Scheme 2.2). When using a 2:1 ratio of cyclopropane to nitrosoarene, a yield of 87% was observed. This observation shows how two equivalents of the cyclopropane may be combining to form a nitron *in situ*, which then reacts with the nitrosoarene. Understanding the mechanics of this unprecedented reaction may lead to the discovery of other reaction types and reaction partners for DA cyclopropanes.

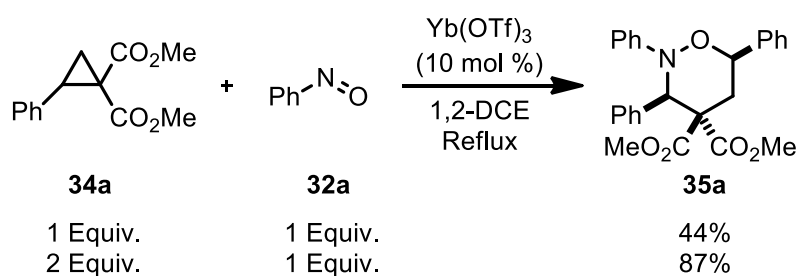

Scheme 2.2 Reaction of DA cyclopropane with nitrosoarene

The physical properties of the tetrahydro-1,2-oxazine produced by this method are an exact match to the tetrahydro-1,2-oxazine produced from Kerr's methodology. The ^1H NMR of compound **35a** prepared from DA cyclopropane **34a** and nitrosobenzene **32a** is shown in Figure 2.2.

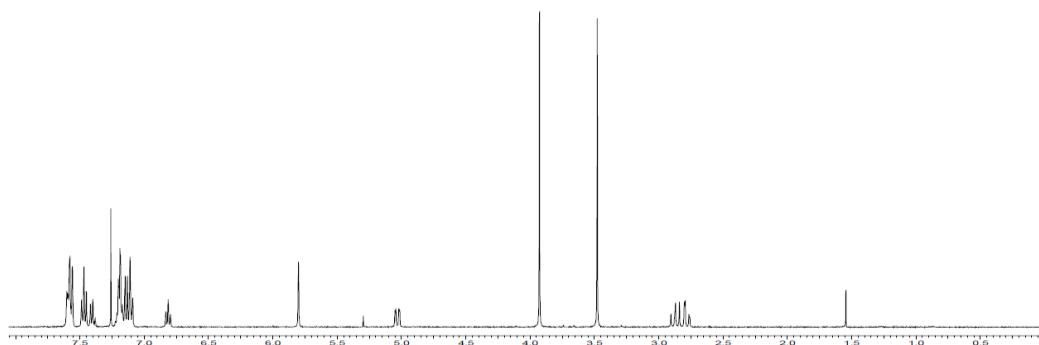

Figure 2.2 ^1H NMR of tetrahydro-1,2-oxazine **35a**

The NMR of the product from scheme 2.2 was compared to the identical compound synthesized using Kerr's three-component coupling strategy and is shown in Scheme 2.3 and Figure 2.3.

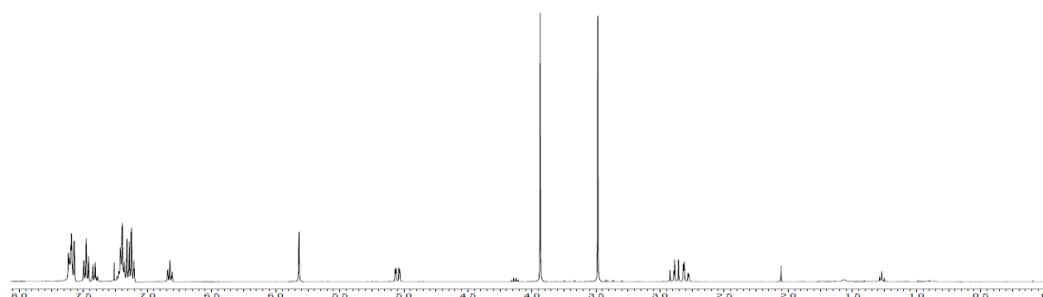
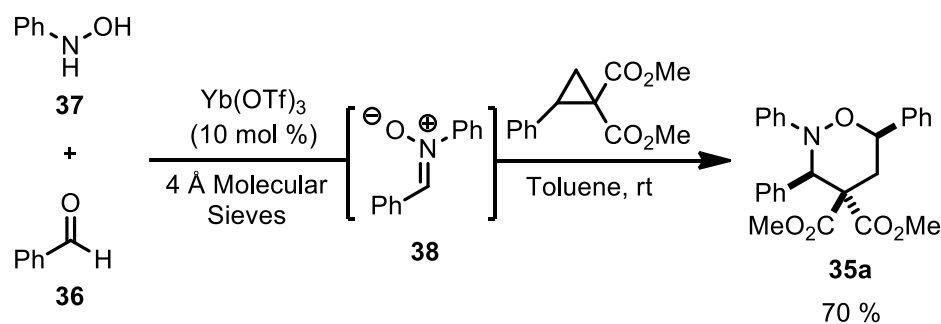
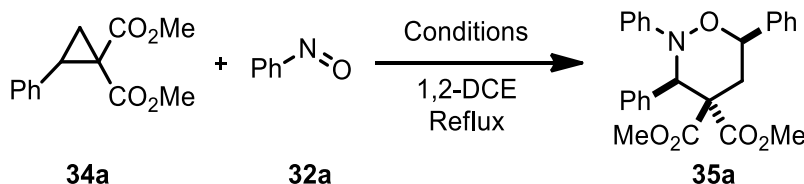

Figure 2.3 ^1H NMR of tetrahydro-1,2-oxazine **35a** prepared from Kerr's method

The matching NMR data provided experimental evidence that both methods lead to the same compound and, therefore, access to tetrahydro-1,2-oxazine is possible when reacting 1,1-cyclopropane diesters with nitrosoarene compounds.

To find reaction conditions that produce the highest yields and come to a better understanding of this reaction, an optimization experiment was carried out (Table 2.1). The reaction of DA cyclopropanes with nitrosoarenes was performed under different conditions until the production of tetrahydro-1,2-oxazine was achieved in an efficient and reproducible manner.

Table 2.1 Optimization of Yb(OTf)₃ catalyzed reaction of DA cyclopropanes with nitrosoarene

Entry ^a	Cyclopropane (Equivalents)	Nitrosoarene (Equivalents)	Time (Hours)	Yb(OTf) ₃ (mol %)	Yield (%) ^b
1	1	2	20	10	42
2	1	1	20	10	44
3	2	1	18	10	87
4	4	1	16	10	76
5	2	1	15	5	72
6	2	1	9	20	80

^a Typical reaction conditions: Cyclopropane and nitrosoarene were added to a solution of Yb(OTf)₃ in 1,2-DCE (3 mL) at room temperature. Reactions were monitored by thin layer chromatography (TLC) until cyclopropane was consumed. ^b Isolated yield.

A cross-over experiment, which is a method used to study the mechanism of a chemical reaction, was used to address this reaction and the experimental evidence gained would help develop a rational reaction mechanism. A mechanism that would account for this overall transformation is shown in Scheme 2.4, and demonstrates how the nitrosoarene starts by attacking the first equivalent of cyclopropane, then forming a nitronne *in situ*. The nitronne would then react with the second equivalent of cyclopropane, in a known homo [3+2] cycloaddition, shown in a step-wise sequence.

Table 2.2 Synthesis of DA cyclopropanes

Entry ^a	Cyclopropane	Product	Yield (% over 2 steps) ^b
1	Ar = C ₆ H ₅ , R = Me	34a	76
2	Ar = 4-MeC ₆ H ₄ , R = Me	34b	87
3	Ar = C ₆ H ₅ , R = Et	34c	82
4	Ar = 4-MeC ₆ H ₄ , R = Et	34d	83
5	Ar = 2-thienyl, R = Me	34e	70

^a Typical reaction conditions: L-Proline (1.88 mmol) was added to a solution of aldehyde (18.8 mmol) in DMSO (6 mL) followed by dialkyl malonate (37.6 mmol) and stirred for 24 h at room temperature. NaH (1.7 mmol) was added to trimethylsulfoxonium iodide (1.7 mmol) in DMF (3 mL) and stirred for 1 h at room temperature before adding the Knoevenagel product (1.4 mmol). Reactions were monitored by TLC until cyclopropane was consumed. ^b Isolated yield.

2.2.2 Cross-Over Experiment #1

Using starting material that consisted of two different DA cyclopropanes (**34a**, **34d**) would, in theory, generate two different nitron intermediates (**38**, **43**) as seen in Scheme 2.5. Nitron intermediate **38** would react with cyclopropane **34a** and cyclopropane **34d** giving rise to products **35a** and **35c**. The other nitron intermediate (**43**) would react again with cyclopropane **34a** and cyclopropane **34d**, giving rise to products **35b** and **35d**. Identification of all four products in the reaction mixture would confirm that a reaction is taking place in which there is cross-over between the two different cyclopropanes and the two different nitron intermediates.

The four expected products were synthesized individually from a three component coupling, homo [3+2] dipolar cycloaddition. Once each tetrahydro-1,2-oxazine product was

synthesized, they were used as standards and compared against the reaction mixture of the cross-over experiment. The three component coupling reaction was performed by making a nitron *in situ* from the respective aldehyde and hydroxylamine as seen in Table 2.3.

Table 2.3 Synthesis of tetrahydro-1,2-oxazine standards

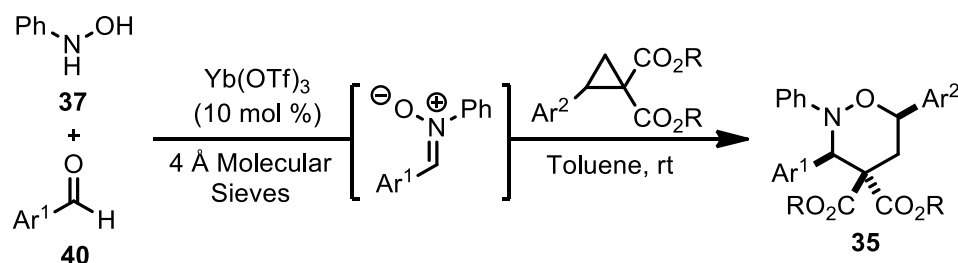

Entry ^a	Aldehyde	Cyclopropane	Product	Yield (%) ^b
1	Ar ¹ = C ₆ H ₅	Ar ² = C ₆ H ₅ , R = Me	35a	64
2	Ar ¹ = 4-MeC ₆ H ₄	Ar ² = C ₆ H ₅ , R = Me	35b	81
3	Ar ¹ = C ₆ H ₅	Ar ² = 4-MeC ₆ H ₄ , R = Et	35c	77
4	Ar ¹ = 4-MeC ₆ H ₄	Ar ² = 4-MeC ₆ H ₄ , R = Et	35d	63

^a Typical reaction conditions: To a solution of hydroxylamine (0.46 mmol) and aldehyde (0.50 mmol) in toluene (2 mL) at room temperature, were added Yb(OTf)₃ and 4 Å molecular sieves. Reactions were monitored by TLC. ^b Isolated yield.

After synthesis and characterization, the standards with their respective R_f values were spotted against the reaction mixture of the cross-over experiment and developed in Hexanes:Ethyl Acetate (3:1) on a TLC plate. All four standards in the reaction mixture were identified. All four tetrahydro-1,2-oxazines (**35a** - **35d**) were isolated from the reaction mixture of cross-over experiment #1 to provide isolated yields as seen in Scheme 2.5. All four products in the reaction mixture (from cross-over experiment #1) was verified with NMR and GC-MS data, which were analyzed by comparison to the individual standards produced from Table 2.3

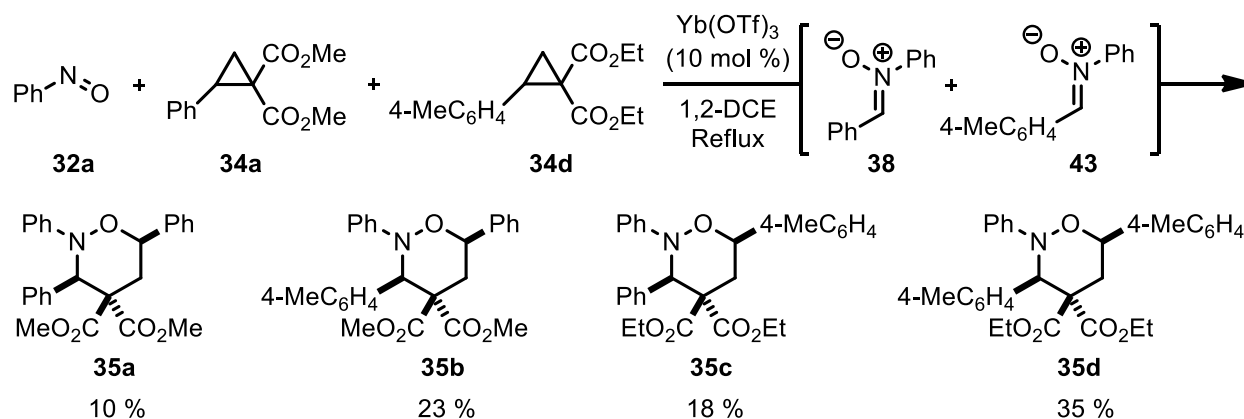

Scheme 2.5 Cross-over experiment for the reaction of DA cyclopropanes with nitrosoarenes

2.2.3 Reaction Scope

After gaining a better understanding and optimizing the reaction of DA cyclopropanes with nitrosoarenes, the optimal conditions were applied to other nitrosoarenes to investigate and expand the reactions scope, as seen in Table 2.4.

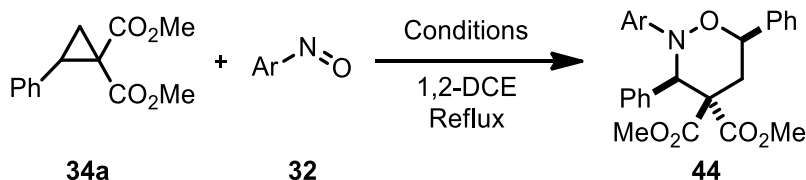
Table 2.4 Reaction scope with different nitrosoarenes

Entry ^a	Nitrosoarene	Product	Yield (%) ^b
1	Ar = 3-BrC ₆ H ₄	44a	73
2	Ar = 4-BrC ₆ H ₄	44b	75
3	Ar = 3-CO ₂ EtC ₆ H ₄	44c	80
4	Ar = 4-CO ₂ EtC ₆ H ₄	44d	78
5	Ar = 3,4-Cl ₂ C ₆ H ₃	44e	91
6	Ar = 3-C(O)MeC ₆ H ₄	44f	68
7	Ar = N-Boc-5-Indole	44g	55

^a Typical reaction conditions: To a solution of Yb(OTf)₃ in 1,2-DCE (3 mL) at room temperature, was added cyclopropane (0.43 mmol) and nitrosoarene (0.22 mmol). Reactions were monitored by TLC until cyclopropane was consumed. ^b Isolated yield.

After expansion of the reaction scope to include different nitrosoarenes, additional DA cyclopropanes were explored. Table 2.5 shows different DA cyclopropanes that are compatible with the reaction conditions in forming tetrahydro-1,2-oxazines.

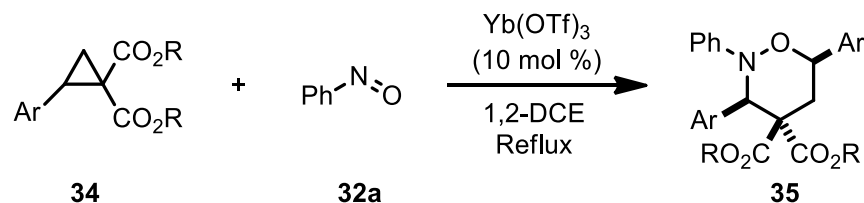
Table 2.5 Reaction scope with different DA cyclopropanes

Entry ^a	Cyclopropane	Product	Yield (%) ^b
1	Ar = C ₆ H ₅ , R = Me	35a	87
2	Ar = C ₆ H ₅ , R = Et	35e	62
3	Ar = 4-MeC ₆ H ₄ , R = Me	35f	46
4	Ar = 4-MeC ₆ H ₄ , R = Et	35d	70
5	Ar = 2-thienyl, R = Me	35g	69

^a Typical reaction conditions: To a solution of Yb(OTf)₃ in 1,2-DCE (3 mL) at room temperature, was added cyclopropane (0.43 mmol) and nitrosoarene (0.22 mmol). Reactions were monitored by TLC until cyclopropane was consumed. ^b Isolated yield.

A new method of synthesizing tetrahydro-1,2-oxazines from DA cyclopropanes and nitrosoarenes under Yb(OTf)₃ catalysis has been developed. A mechanism that accounts for this overall transformation has been presented and experimental data obtained from a cross-over experiment provided supporting evidence. The reaction scope was investigated and it was found that the reaction conditions were compatible with different nitrosoarenes and DA cyclopropanes.

2.3 Experimental

All reactions were performed in an atmosphere of dry argon unless otherwise noted. Flasks were oven-dried at approximately 110 °C overnight and cooled in a desiccator prior to use. Solvents and reagents were purified according to standard procedures. Dichloromethane was purified by passing the solvent through a column of activated alumina. 1,2-Dichloroethane was dried by stirring with CaH₂ for one hour prior to distillation. All other chemicals were of reagent quality and used as obtained from commercial sources unless otherwise noted. The progress of reactions was monitored by TLC performed on F254 silica gel plates. The plates were visualized using UV light (254 nm) or by staining with ceric ammonium molybdate (CAM) or KMnO₄. Column chromatography was performed with Silica Flash P60 60 Å silica gel (purchased from Silicycle) using flash column chromatography techniques.

¹H and ¹³C NMR data were obtained on Mercury 400 or Inova 600 MHz spectrometers and chemical shifts were reported in parts per million (ppm). All spectra were obtained in deuterated chloroform and referenced to residual chloroform at δ 7.26 ppm for ¹H spectra and the center peak of the triplet at δ 77.0 ppm for ¹³C spectra. When peak multiplicities are given, abbreviations are as follows: s, singlet; d, doublet; t, triplet; q, quartet; dd, doublet of doublets; dt, doublet of triplets; m, multiplet. EI high-resolution mass spectra (HRMS) were recorded on a Finnigan MAT 8200 mass spectrometer at an ionizing voltage of 70 eV.

2.4 Supporting Information

General Three Component Coupling Procedure

To a solution of hydroxylamine (0.46 mmol, 1.3 equiv) and aldehyde (0.50 mmol, 1.4 equiv), in toluene (2 mL) was added 4Å molecular sieves and Yb(OTf)₃ (0.04 mmol, 0.1 equiv) and stirred for 30 min. Cyclopropane (0.36 mmol, 1.0 equiv) was then added and stirred for 20 h at rt, then directly loaded onto a packed SiO₂ column. Product was purified by flash chromatography (9:1 hexanes/EtOAc) to afford the corresponding cycloadducts.

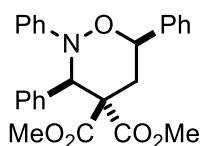

Dimethyl 2,3,6-triphenyl-1,2-oxazinane-4,4-dicarboxylate (35a)

The general three component coupling procedure was followed using hydroxylamine (50 mg, 0.46 mmol), aldehyde (0.05 mL, 0.50 mmol), Yb(OTf)₃ (22 mg, 0.036 mmol) and cyclopropane **34a** (84 mg, 0.36 mmol) to yield the compound as a yellow oil. The yellow oil was recrystallized with CH₂Cl₂/Hexane to give a white solid (100 mg, 64%). R_f 0.40 (3:1 Hexanes:EtOAc); ¹H NMR (400 MHz, CDCl₃) 7.56 - 7.60 (m, 4 H), 7.47 (app t, J = 7.4 Hz, 2 H), 7.38 - 7.42 (m, 1 H), 7.09 - 7.22 (m, 7 H), 6.81 (app t, J = 7.0 Hz, 1 H), 5.80 (s, 1 H), 5.03 (dd, J = 12.1, 2.3 Hz, 1 H), 3.93 (s, 3 H), 3.48 (s, 3 H), 2.86 (dd, J = 14.5, 12.1 Hz, 1 H), 2.78 (dd, J = 14.5, 2.3 Hz, 1 H); ¹³C NMR (100 MHz, CDCl₃) 170.1, 168.3, 148.5, 139.4, 135.0, 130.4, 128.6, 128.5, 128.3, 128.1, 128.0, 126.5, 121.6, 115.8, 78.8, 65.7, 59.5, 53.5, 52.6, 31.6; HRMS C₂₆H₂₅NO₅ Calculated = 431.1733, Found = 431.1736

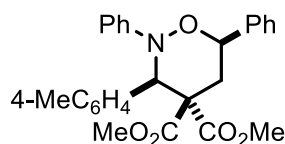

Dimethyl 2,6-diphenyl-3-(p-tolyl)-1,2-oxazinane-4,4-dicarboxylate (35b)

The general three component coupling procedure was followed using hydroxylamine (60 mg, 0.55 mmol), aldehyde (0.07 mL, 0.60 mmol), Yb(OTf)₃ (27 mg, 0.043 mmol) and cyclopropane **34a** (100 mg, 0.43 mmol) to yield the compound as a yellow oil. The yellow oil was recrystallized with CH₂Cl₂/Hexane to give a white solid (155 mg, 81%). R_f 0.45 (3:1 Hexanes:EtOAc); ¹H NMR (400 MHz, CDCl₃) 7.57 (app d, J = 7.4 Hz, 2 H), 7.45 - 7.49 (m, 4 H), 7.38 - 7.42 (m, 1 H), 7.09 - 7.17 (m, 4 H), 7.00 (app d, J = 7.8 Hz, 2 H), 6.79 - 6.83 (m, 1 H), 5.78 (s, 1 H), 5.03 (dd, J = 12.1, 2.3 Hz, 1 H), 3.92 (s, 3 H), 3.51 (s, 3 H), 2.87 (dd, J = 14.5, 12.1 Hz, 1 H), 2.78 (dd, J = 14.5, 2.3 Hz, 1 H), 2.23 (s, 3 H); ¹³C NMR (100 MHz, CDCl₃) 170.1, 168.3, 148.6, 139.5, 137.6, 131.9, 130.3, 121.5, 115.7, 78.8, 77.3, 76.7, 65.4, 59.6, 53.5, 52.7, 31.6, 21.1; HRMS C₂₇H₂₇NO₅ Calculated = 445.1889, Found = 445.1882

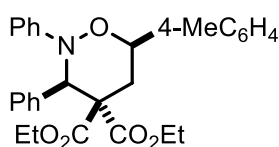

Diethyl 2,3-diphenyl-6-(p-tolyl)-1,2-oxazinane-4,4-dicarboxylate (35c)

The general three component coupling procedure was followed using hydroxylamine (50 mg, 0.46 mmol), aldehyde (0.05 mL, 0.50 mmol), Yb(OTf)₃ (22 mg, 0.036 mmol) and cyclopropane **34d** (100 mg, 0.36 mmol) to yield the compound as a yellow oil. The yellow oil was recrystallized with CH₂Cl₂/Hexane to give a white solid (132 mg, 77%). R_f 0.55 (3:1 Hexanes:EtOAc); ¹H NMR (400 MHz, CDCl₃) 7.57 - 7.59 (m, 2 H), 7.45 (app d, J = 8.2 Hz, 2 H), 7.28 (s, 1 H), 7.08 - 7.17 (m, 7 H), 6.80 (app t, J = 7.0 Hz, 1 H), 5.78 (s, 1 H), 5.00 (dd, J = 12.1, 2.3 Hz, 1 H), 4.38 (q, J = 7.0 Hz, 2 H), 3.87 - 3.94 (dddd, J = 7.0, 7.0, 7.0, 10.5 Hz, 2 H), 2.87 (dd, J = 14.5, 12.1 Hz, 1 H), 2.76 (dd, J = 14.5, 2.3 Hz, 1 H), 2.41 (s, 3 H), 1.36 (t, J = 7.2 Hz, 3 H), 1.03 (t, J = 7.0 Hz, 3 H); ¹³C NMR (100 MHz, CDCl₃) 169.6, 168.0, 148.7, 138.1, 136.6, 135.1, 130.6, 129.3, 128.5, 128.0, 127.9, 126.5, 121.4, 115.8, 78.7, 65.7, 62.3, 61.8, 59.4, 31.7, 21.3, 14.2, 13.7; HRMS C₂₉H₃₁NO₅ Calculated = 473.2202, Found = 473.2195

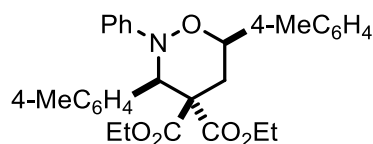

Diethyl 2-phenyl-3,6-di-p-tolyl-1,2-oxazinane-4,4-dicarboxylate (35d)

The general three component coupling procedure was followed using hydroxylamine (50 mg, 0.46 mmol), aldehyde (0.05 mL, 0.50 mmol), Yb(OTf)₃ (22 mg, 0.036 mmol) and cyclopropane **34d** (100 mg, 0.36 mmol) to yield the compound as a yellow oil. The yellow oil was recrystallized with CH₂Cl₂/Hexane to give a white solid (190 mg, 63%). R_f 0.58 (3:1 Hexanes:EtOAc); ¹H NMR (400 MHz, CDCl₃) 7.44 - 7.47 (app dd, J = 8.2, 6.6 Hz, 4 H), 7.27 (app d, J = 8.2 Hz, 2 H), 7.08 - 7.16 (m, 4 H), 6.97 (app d, J = 8.2 Hz, 2 H), 6.79 (app tt, J = 7.0, 1.6 Hz, 1 H), 5.75 (s, 1 H), 4.98 (dd, J = 14.5, 2.3 Hz, 1 H), 4.38 (q, J = 7.0 Hz, 2 H), 3.85 - 3.99 (dddd, J = 7.0, 7.0, 7.0, 10.5 Hz, 2 H), 2.86 (dd, J = 14.5, 12.5 Hz, 1 H), 2.74 (dd, J = 14.5, 2.3 Hz, 1 H), 2.41 (s, 3 H), 2.21 (s, 3 H), 1.35 (t, J = 7.0 Hz, 3 H), 1.06 (t, J = 7.0 Hz, 3 H); ¹³C NMR (100 MHz, CDCl₃) 169.7, 168.0, 148.7, 138.1, 137.5, 136.6, 131.9, 130.5, 129.3, 128.6, 128.5, 126.5, 121.3, 115.7, 78.7, 65.4, 62.2, 61.7, 59.4, 31.7, 21.2, 21.0, 14.2, 13.7; HRMS C₃₀H₃₃NO₅ Calculated = 487.2359, Found = 487.2348

General Lewis Acid Catalyzed Cycloaddition Procedure

To a solution of cyclopropane (0.43 mmol, 2.1 equiv) and nitrosoarene (0.20 mmol, 1.0 equiv) in DCE (3 mL) was added Yb(OTf)₃ (0.02 mmol, 0.1 equiv) and stirred for 15 min. The mixture was heated to reflux for 3 h then concentrated after consumption of cyclopropane (as indicated by TLC) and directly loaded onto a packed SiO₂ column. Product was purified by flash chromatography (9:1 hexanes/EtOAc) to afford the corresponding cycloadducts.

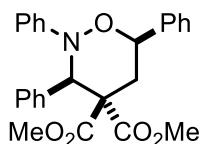

Dimethyl 2,3,6-triphenyl-1,2-oxazinane-4,4-dicarboxylate (35a)

The general Lewis acid cycloaddition procedure was followed using cyclopropane **34a** (100 mg, 0.43 mmol), nitrosobenzene (21 mg, 0.20 mmol) and Yb(OTf)₃ (12 mg, 0.020 mmol) to yield the compound as a yellow oil, which was recrystallized with CH₂Cl₂/Hexane to give a white solid (75 mg, 87%). R_f 0.40 (3:1 Hexanes:EtOAc); ¹H NMR (400 MHz, CDCl₃) 7.56 - 7.60 (m, 4 H), 7.47 (app t, J = 7.4 Hz, 2 H), 7.38 - 7.42 (m, 1 H), 7.09 - 7.22 (m, 7 H), 6.81 (app t, J = 7.0 Hz, 1 H), 5.80 (s, 1 H), 5.03 (dd, J = 12.1, 2.3 Hz, 1 H), 3.93 (s, 3 H), 3.48 (s, 3 H), 2.86 (dd, J = 14.5, 12.1 Hz, 1 H), 2.78 (dd, J = 14.5, 2.3 Hz, 1 H); ¹³C NMR (100 MHz, CDCl₃) 170.1, 168.3, 148.5, 139.4, 135.0, 130.4, 128.6, 128.5, 128.3, 128.1, 128.0, 126.5, 121.6, 115.8, 78.8, 65.7, 59.5, 53.5, 52.6, 31.6; HRMS C₂₆H₂₅NO₅ Calculated = 431.1733, Found = 431.1736

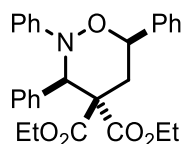

Diethyl 2,3,6-triphenyl-1,2-oxazinane-4,4-dicarboxylate (35e)

The general Lewis acid cycloaddition procedure was followed using cyclopropane **34c** (50 mg, 0.19 mmol), nitrosobenzene (10 mg, 0.095 mmol) and Yb(OTf)₃ (12 mg, 0.019 mmol) to yield the compound as a yellow oil, which was recrystallized with CH₂Cl₂/Hexane to give a white solid (28 mg, 62%). R_f 0.46 (3:1 Hexanes:EtOAc); ¹H NMR (400 MHz, CDCl₃) 7.55 - 7.60 (m, 4 H), 7.47 (app t, J = 7.2 Hz, 2 H), 7.38 - 7.41 (m, 1 H), 7.09 - 7.20 (m, 7 H), 6.81 (app tt, J = 7.0, 1.6 Hz, 1 H), 5.79 (s, 1 H), 5.03 (dd, J = 12.1, 2.3 Hz, 1 H), 4.40 (q, J = 7.0 Hz, 2 H), 3.83 - 3.99 (dddd, J = 7.0, 7.0, 7.0, 10.5 Hz, 2 H), 2.87 (dd, J = 14.5, 12.1 Hz, 1 H), 2.79 (dd, J = 14.5, 2.3 Hz, 1 H), 1.37 (t, J = 7.2 Hz, 3 H), 1.03 (t, J = 7.2 Hz, 3 H); ¹³C NMR (100 MHz, CDCl₃) 169.6, 167.9, 148.6, 139.6, 135.0, 130.6, 128.6, 128.5, 128.2, 128.0, 127.9, 126.4, 121.5, 115.8, 78.8, 65.8, 62.3, 61.8, 59.3, 31.9, 14.2, 13.7; HRMS C₂₈H₂₉NO₅ Calculated = 459.2046, Found = 459.2027

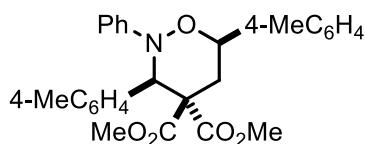

Dimethyl 2-phenyl-3,6-di-p-tolyl-1,2-oxazinane-4,4-dicarboxylate (35f)

The general Lewis acid cycloaddition procedure was followed using cyclopropane **34b** (50 mg, 0.20 mmol), nitrosobenzene (11 mg, 0.10 mmol) and Yb(OTf)₃ (12 mg, 0.020 mmol) to yield the compound as a yellow oil, which was recrystallized with CH₂Cl₂/Hexane to give a white solid (21 mg, 46%). R_f 0.60 (3:1 Hexanes:EtOAc); ¹H NMR (400 MHz, CDCl₃) 7.45 - 7.48 (m, 4 H), 7.27 (app d, J = 8.2 Hz, 2 H), 7.07 - 7.14 (m, 4 H), 6.99 (app d, J = 7.8 Hz, 2 H), 6.80 (app tt, J = 8.2, 1.2 Hz, 1 H), 5.76 (s, 1 H), 4.98 (dd, J = 12.1, 2.3 Hz, 1 H), 3.91 (s, 3 H), 3.50 (s, 3 H), 2.86 (dd, J = 14.5, 12.1 Hz, 1 H), 2.74 (dd, J = 14.5, 2.3 Hz, 1 H), 2.41 (s, 3 H), 2.22 (s, 3 H); ¹³C NMR (100 MHz, CDCl₃) 170.2, 168.4, 148.6, 143.0, 138.2, 137.6, 136.4, 131.9, 130.3, 129.7, 129.5, 129.3, 129.2, 128.7, 128.5, 126.6, 126.5, 121.4, 115.7, 78.7, 65.3, 59.6, 53.4, 52.6, 31.4, 21.3, 21.1; HRMS C₂₈H₂₉NO₅ Calculated = 459.2046, Found = 459.2027

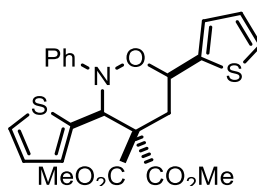

Dimethyl 2-phenyl-3,6-di(thiophen-2-yl)-1,2-oxazinane-4,4-dicarboxylate (35g)

The general Lewis acid cycloaddition procedure was followed using cyclopropane **34e** (100 mg, 0.42 mmol), nitrosobenzene (121 mg, 0.20 mmol) and Yb(OTf)₃ (12 mg, 0.020 mmol) to yield the compound as a yellow oil, which was recrystallized with CH₂Cl₂/Hexane to give a white solid (61 mg, 69%). R_f 0.39 (3:1 Hexanes:EtOAc); ¹H NMR (400 MHz, CDCl₃) 7.40 (app d, J = 5.1 Hz, 1 H), 7.25 (app d, J = 3.9 Hz, 1 H), 7.15 - 7.20 (m, 3 H), 7.06 - 7.13 (m, 3 H), 6.95 (app d, J = 3.5 Hz, 1 H), 6.88 (app t, J = 7.4 Hz, 1 H), 6.80 - 6.84 (m, 1 H), 6.09 (s, 1 H), 5.27 (dd, J = 12.1, 2.3 Hz, 1 H), 3.92 (s, 3 H), 3.59 (s, 3 H), 2.99 (dd, J = 14.5, 12.1 Hz, 1 H), 2.88 (dd, J = 14.5, 2.3 Hz, 1 H); ¹³C NMR (100 MHz, CDCl₃) 169.3, 167.7, 148.1, 141.5, 133.8, 129.2, 128.5, 127.2, 126.7, 126.0, 125.8, 125.4, 122.4, 116.3, 75.0, 64.3, 59.7, 53.6, 52.9, 32.3; HRMS C₂₂H₂₁NO₅S₂ Calculated = 443.0861, Found = 443.0864

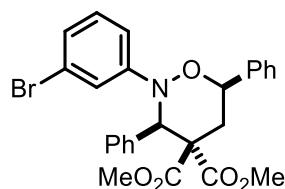

Dimethyl 2-(3-bromophenyl)-3,6-diphenyl-1,2-oxazinane-4,4-dicarboxylate (44a)

The general Lewis acid cycloaddition procedure was followed using cyclopropane **34a** (100 mg, 0.43 mmol), nitrosoarene (20 mg, 0.11 mmol) and Yb(OTf)₃ (6 mg, 0.010 mmol) to yield the compound as a yellow oil, which was recrystallized with CH₂Cl₂/Hexane to give a white solid (41 mg, 73%). R_f 0.38 (3:1 Hexanes:EtOAc); ¹H NMR (400 MHz, CDCl₃) 7.54 - 7.60 (m, 4 H), 7.46 - 7.50 (m, 2 H), 7.40 - 7.43 (m, 1 H), 7.22 - 7.24 (m, 3 H), 6.99 - 7.01 (m, 2 H), 6.91 - 6.94 (m, 1 H), 5.76 (s, 1 H), 4.99 (dd, J = 12.1, 2.3 Hz, 1 H), 3.92 (s, 3 H), 3.49 (s, 3 H), 2.87 (dd, J = 14.5, 12.1 Hz, 1 H), 2.76 (dd, J = 14.5, 2.3 Hz, 1 H); ¹³C NMR (100 MHz, CDCl₃) 169.9, 168.0, 138.9, 134.5, 130.2, 129.9, 128.7, 128.5, 128.3, 128.2, 126.6, 124.4, 122.7, 118.6, 114.0, 79.1, 59.4, 53.6, 52.7; HRMS C₂₆H₂₄BrNO₅ Calculated = 509.0838, Found = 509.0823

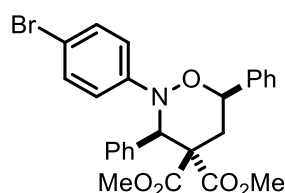

Dimethyl 2-(4-bromophenyl)-3,6-diphenyl-1,2-oxazinane-4,4-dicarboxylate (44b)

The general Lewis acid cycloaddition procedure was followed using cyclopropane **34a** (100 mg, 0.43 mmol), nitrosoarene (37 mg, 0.20 mmol) and Yb(OTf)₃ (12 mg, 0.020 mmol) to yield the compound as a yellow oil, which was recrystallized with CH₂Cl₂/Hexane to give a white solid (75 mg, 75%). R_f 0.34 (3:1 Hexanes:EtOAc); ¹H NMR (400 MHz, CDCl₃) 7.53 - 7.57 (m, 4 H), 7.45 - 7.47 (m, 2 H), 7.38 - 7.42 (m, 1 H), 7.18 - 7.20 (m, 5 H), 6.96 - 6.98 (m, 2 H), 5.73 (s, 1 H), 5.00 (dd, J = 12.1, 2.7 Hz, 1 H), 3.92 (s, 3 H), 3.48 (s, 3 H), 2.87 (dd, J = 14.5, 12.1 Hz, 1 H), 2.76 (dd, J = 14.5, 2.7 Hz, 1 H); ¹³C NMR (100 MHz, CDCl₃) 168.1, 147.6, 139.0, 134.6, 131.4, 130.3, 128.7, 128.5, 128.3, 128.1, 126.5, 117.5, 114.1, 79.0, 65.6, 59.4, 53.6, 52.7, 31.5; HRMS C₂₆H₂₄BrNO₅ Calculated = 509.0838, Found = 509.0830

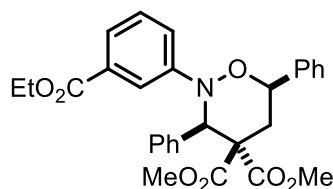

Dimethyl 2-(3-(ethoxycarbonyl)phenyl)-3,6-diphenyl-1,2-oxazinane-4,4-dicarboxylate (44c)

The general Lewis acid cycloaddition procedure was followed using cyclopropane **34a** (100 mg, 0.43 mmol), nitrosoarene (39 mg, 0.22 mmol) and Yb(OTf)₃ (12 mg, 0.020 mmol) to yield the compound as a yellow oil, which was recrystallized with CH₂Cl₂/Hexane to give a white solid (88 mg, 80%). R_f 0.29 (3:1 Hexanes:EtOAc); ¹H NMR (400 MHz, CDCl₃) 7.75 (app t, J = 1.6 Hz, 1 H), 7.55 - 7.62 (m, 4 H), 7.45 - 7.51 (m, 3 H), 7.39 - 7.43 (m, 1 H), 7.27 - 7.32 (m, 1 H), 7.17 - 7.22 (m, 4 H), 5.85 (s, 1 H), 5.02 (dd, J = 12.1, 2.3 Hz, 1 H), 4.32 (q, J = 7.0 Hz, 2 H), 3.93 (s, 3 H), 3.49 (s, 3 H), 2.90 (dd, J = 14.5, 12.1 Hz, 1 H), 2.77 (dd, J = 14.5, 2.3 Hz, 1 H), 1.35 (t, J = 7.2 Hz, 3 H); ¹³C NMR (100 MHz, CDCl₃) 170.0, 168.1, 166.6, 148.6, 139.1, 134.6, 130.4, 128.7, 128.6, 128.4, 128.2, 128.1, 126.5, 122.6, 120.1, 116.6, 79.0, 65.3, 60.9, 59.4, 53.6, 52.7, 31.6, 14.3; HRMS C₂₉H₂₉NO₇ Calculated = 503.1944, Found = 503.1943

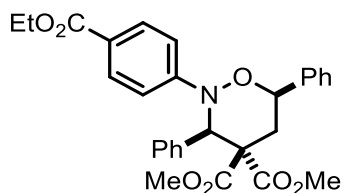

Dimethyl 2-(4-(ethoxycarbonyl)phenyl)-3,6-diphenyl-1,2-oxazinane-4,4-dicarboxylate (44d)

The general Lewis acid cycloaddition procedure was followed using cyclopropane **34a** (106 mg, 0.45 mmol), nitrosoarene (36 mg, 0.20 mmol) and Yb(OTf)₃ (17 mg, 0.027 mmol) to yield the compound as a yellow oil, which was recrystallized to give a white solid (78 mg, 78%). R_f 0.28 (3:1 Hexanes:EtOAc); ¹H NMR (400 MHz, CDCl₃) 7.82 - 7.86 (m, 2 H), 7.54 - 7.61 (m, 4 H), 7.46 - 7.51 (m, 2 H), 7.40 - 7.45 (m, 1 H), 7.19 - 7.24 (m, 3 H), 7.09 - 7.13 (m, 2 H), 5.91 (s, 1 H), 5.00 (dd, J = 12.1, 2.3 Hz, 1 H), 4.27 (q, J = 7.0 Hz, 2 H), 3.92 (s, 3 H), 3.50 (s, 3 H), 2.90 (dd, J = 14.5, 12.1 Hz, 1 H), 2.77 (dd, J = 14.5, 2.3 Hz, 1 H), 1.32 (t, J = 7.2 Hz, 3 H); ¹³C NMR (100 MHz, CDCl₃) 169.9, 168.0, 166.4, 151.9, 138.7, 134.7, 130.6, 130.0, 128.8, 128.6, 128.4, 128.2, 126.6,

122.8, 114.2, 79.1, 64.4, 60.5, 53.6, 52.8, 31.5, 14.3; HRMS C₂₉H₂₉NO₇ Calculated = 503.1944, Found = 503.1943

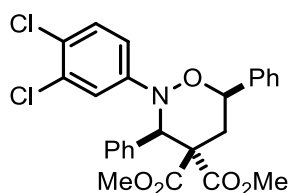

Dimethyl 2-(3,4-dichlorophenyl)-3,6-diphenyl-1,2-oxazinane-4,4-dicarboxylate (44e)

The general Lewis acid cycloaddition procedure was followed using cyclopropane **34a** (57 mg, 0.24 mmol), nitrosoarene (19 mg, 0.11 mmol) and Yb(OTf)₃ (6 mg, 0.010 mmol) to yield the compound as a yellow oil, which was recrystallized with CH₂Cl₂/Hexane to give a white solid (50 mg, 91%). R_f 0.55 (3:1 Hexanes:EtOAc); ¹H NMR (400 MHz, CDCl₃) 7.53 - 7.58 (m, 4 H), 7.46 - 7.50 (m, 2 H), 7.40 - 7.44 (m, 1 H), 7.22 - 7.25 (m, 3 H), 7.17 - 7.19 (m, 2 H), 6.89 - 6.92 (app dd, J = 9.0, 2.7 Hz, 1 H), 5.72 (s, 1 H), 4.98 (dd, J = 12.3, 2.4 Hz, 1 H), 3.92 (s, 3 H), 3.48 (s, 3 H), 2.87 (dd, J = 14.7, 12.3 Hz, 1 H), 2.74 (dd, J = 14.7, 2.4 Hz, 1 H); ¹³C NMR (100 MHz, CDCl₃) 167.9, 147.9, 138.7, 134.3, 132.5, 130.2, 130.1, 128.8, 128.7, 128.5, 128.3, 126.6, 124.5, 117.5, 114.9, 79.3, 65.3, 59.2, 53.6, 52.8, 31.4; HRMS C₂₆H₂₃Cl₂NO₅ Calculated = 499.0953, Found = 499.0952

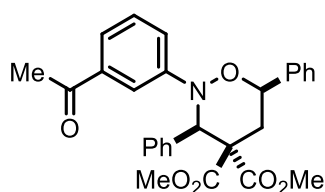

Dimethyl 2-(3-acetylphenyl)-3,6-diphenyl-1,2-oxazinane-4,4-dicarboxylate (44f)

The general Lewis acid cycloaddition procedure was followed using cyclopropane **34a** (100 mg, 0.43 mmol), nitrosoarene (32 mg, 0.21 mmol) and Yb(OTf)₃ (12 mg, 0.020 mmol) to yield the compound as a yellow oil, which was recrystallized with CH₂Cl₂/Hexane to give a white solid (68 mg, 68%). R_f 0.25 (3:1 Hexanes:EtOAc); ¹H NMR (400 MHz, CDCl₃) 7.64 - 7.67 (m, 1 H), 7.55 - 7.62 (m, 4 H), 7.46 - 7.50 (m, 2 H), 7.39 - 7.43 (m, 2 H), 7.30 - 7.34 (m, 1 H), 7.24 - 7.26 (m, 1 H), 7.18 - 7.22 (m, 3 H), 5.85 (s, 1 H), 5.03 (dd, J = 12.1, 2.3 Hz, 1 H), 3.93 (s, 3 H), 3.49 (s, 3 H), 2.89 (dd, J = 14.5, 12.1 Hz, 1 H), 2.79 (dd, J = 14.5, 2.3 Hz, 1 H), 2.50 (s, 3 H); ¹³C NMR (100

MHz, CDCl₃) 170.0, 168.1, 148.8, 137.5, 134.6, 130.3, 128.8, 128.7, 128.5, 128.3, 128.1, 126.5, 121.7, 120.5, 115.1, 79.1, 65.3, 59.4, 53.6, 52.7, 31.6, 26.7; HRMS C₂₈H₂₇NO₆ Calculated = 473.1838, Found = 473.1829

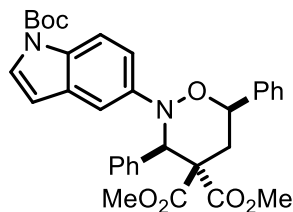

Dimethyl 2-(1-(tert-butoxycarbonyl)-1H-indol-5-yl)-3,6-diphenyl-1,2-oxazinane-4,4-dicarboxylate (44g)

The general Lewis acid cycloaddition procedure was followed using cyclopropane **34a** (50 mg, 0.21 mmol), nitrosoarene (27 mg, 0.11 mmol) and Yb(OTf)₃ (12 mg, 0.020 mmol) to yield the compound as a yellow oil, which was recrystallized with CH₂Cl₂/Hexane to give a white solid (35 mg, 55%). R_f 0.40 (3:1 Hexanes:EtOAc); ¹H NMR (400 MHz, CDCl₃) 8.04 - 8.06 (m, 1 H), 7.56 - 7.61 (m, 4 H), 7.46 - 7.50 (m, 4 H), 7.39 - 7.42 (m, 1 H), 7.26 - 7.27 (m, 1 H), 7.14 - 7.18 (m, 2 H), 7.10 - 7.13 (app dd, J = 9.0, 2.3 Hz, 1 H), 6.38 (app d, J = 3.5 Hz, 1 H), 5.78 (s, 1 H), 5.10 (dd, J = 12.1, 2.3 Hz, 1 H), 3.96 (s, 3 H), 3.47 (s, 3 H), 2.90 (dd, J = 14.5, 12.1 Hz, 1 H), 2.80 (dd, J = 14.5, 2.3 Hz, 1 H), 1.61 (s, 9 H); ¹³C NMR (100 MHz, CDCl₃) 170.2, 168.3, 166.2, 144.5, 139.6, 134.9, 131.0, 130.5, 128.8, 128.6, 128.4, 128.3, 128.0, 127.9, 126.6, 114.9, 107.4, 78.8, 67.3, 59.6, 53.8, 53.5, 52.6, 31.7, 28.2; HRMS C₃₃H₃₄N₂O₇ Calculated = 570.2366, Found = 570.2347

General Lewis Acid Catalyzed Cross-Over Experiment Procedure

To a solution of cyclopropane **34a** (0.43 mmol, 1.0 equiv) and cyclopropane **34d** (0.43 mmol, 1.0 equiv) and nitrosobenzene **32a** (0.43 mmol, 1.0 equiv) in DCE (3 mL) was added Yb(OTf)₃ (0.043 mmol, 0.1 equiv) and stirred for 15 min. The mixture was heated to reflux for 3 h then concentrated after consumption of cyclopropane (as indicated by TLC) and directly loaded onto a packed SiO₂ column. The products were purified by flash chromatography (9:1 hexanes/EtOAc).

Chapter 3 - Cycloadditions of Donor-Acceptor Cyclopropanes with Azo Dicarboxylates

3.1 Introduction

In 2007, Armin de Meijer reported the successful reaction between cyclopropanes and azo dicarboxylates, which give rise to pyrazolidine derivatives (Scheme 3.1). After testing several Lewis acids, GaCl₃ was found to catalyze the reaction, and only trace amounts of product were formed using Yb(OTf)₃. When *trans*-configured diazenes are used, insertion into the cyclopropane ring proceeds with complete regioselectivity to produce the expected 5-arylpyrazolidine-1,2,3,3-tetracarboxylates. The *trans*-configured diazenes used were naturally existing mixtures of minor amounts of *cis*- and major amounts of the thermodynamically favoured *trans*-diastereomers. The reactivity of cyclopropanes towards a fixed *cis*-configuration of the N,N double bond was also investigated. Interestingly, when 4-phenyl-1,2,4-triazoline-3,5-dione (PTAD) was used as a *cis*-configured diazene, two possible regioisomeric pyrazolidine derivatives were formed in ratios varying from 1:1.5 to 1:3.²²

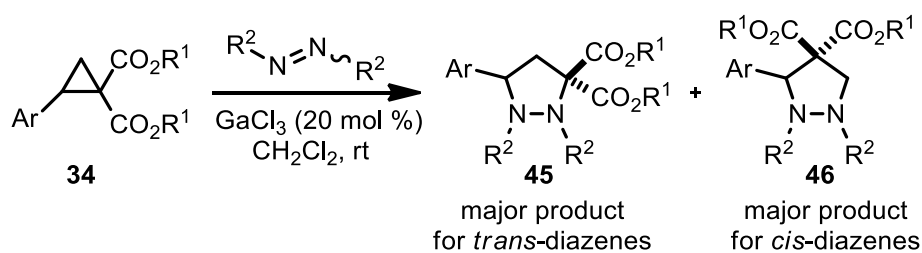

Scheme 3.1 Cycloaddition of DA cyclopropanes with azo dicarboxylates

3.2 Cycloadditions of DA Cyclopropanes with *trans*-Diazenes

The [3+2] cycloaddition reaction of cyclopropanes with *trans*-configured diazenes as seen in Scheme 3.2 was examined in order to investigate the mechanism and hopefully provide a deeper understanding of how cyclopropanes react with nitrogen-heteroatom double bonded compounds. This mode of reactivity may show resemblance to the opening of cyclopropanes with nitrosoarenes, so a cross-over experiment was performed in order to probe the mechanism of the following reaction.

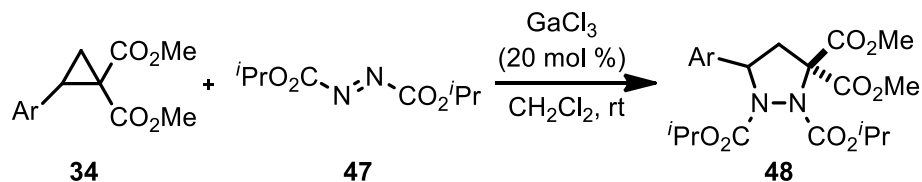

Scheme 3.2 Cycloaddition of DA cyclopropanes with *trans*-diazenes

3.2.1 Cross-Over Experiment #2

To obtain experimental evidence that *trans*-configured diazenes open the cyclopropane ring in a nucleophilic manner, paralleling what happens with nitrosoarenes, a cross-over experiment would have to contain two different cyclopropanes in order to show that a cross-over event occurred. For this cross-over experiment, four different cyclopropanes were used so that four different pyrazolidine standards could be generated, accounting for the possible cross-over based products (Table 3.1). After obtaining the four pyrazolidine standards, the cross-over experiment was performed and the reaction mixture was analyzed.

Table 3.1 Cycloaddition of DA cyclopropanes with *trans*-diazenes

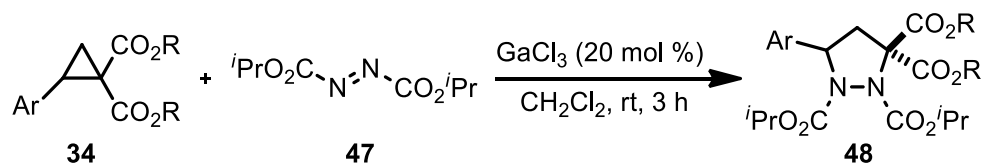

Entry ^a	Cyclopropane	Product	Yield (%) ^b
1	Ar = C ₆ H ₅ , R = Me	48a	58
2	Ar = 4-MeC ₆ H ₄ , R = Me	48b	50
3	Ar = C ₆ H ₅ , R = Et	48c	23
4	Ar = 4-MeC ₆ H ₄ , R = Et	48d	52

^a Typical reaction conditions: To a solution of GaCl₃ in CH₂Cl₂ (0.8 mL) at room temperature, was added cyclopropane (0.21 mmol) and *trans*-diazene (0.29 mmol). Reactions were monitored by TLC until cyclopropane was consumed. ^b Isolated yield.

Separation of the reaction mixture was performed using column chromatography and only two products had formed, as seen in Scheme 3.3.

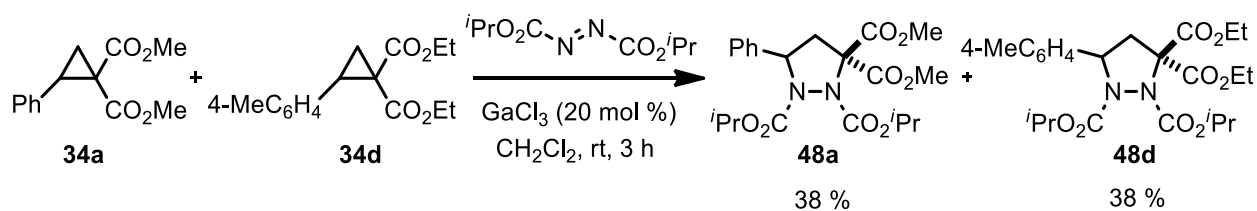

Scheme 3.3 Cross-over experiment of DA cyclopropanes with *trans*-diazenes

The expected [3+2] cycloaddition products were observed with no cross-over. This provides evidence of a straight forward [3+2] cycloaddition with nothing unusual observed with *trans*-diazenes.

3.3 Cycloadditions of DA Cyclopropanes with *cis*-Diazenes

The cycloaddition product from DA cyclopropane and *cis*-configured diazene PTAD produces an unusual pyrazolidine derivative, which may have arisen from insertion into the C(2)-C(3) bond of the cyclopropane (Scheme 3.4). Because of this surprisingly different mode of cyclopropane reactivity, the reaction of DA cyclopropanes with *trans*-diazenes must operate through a different type of mechanism than *cis*-diazenes. A cross-over experiment was performed to investigate how this unusual pyrazolidine derivative product was formed. Understanding how cyclopropanes can undergo this rare insertion into the C(2)-C(3) bond would be useful for its application in synthesis.

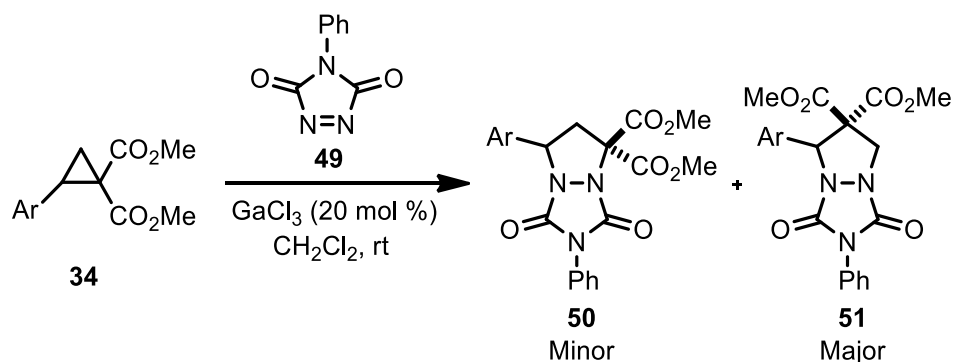

Scheme 3.4 Cycloaddition of DA cyclopropanes with *cis*-diazenes

A mechanism was proposed by de Meijer to account for the unusual reactivity of the DA cyclopropane when it encounters the Lewis activated *cis*-diazene (Figure 3.1). It would be very difficult to prove how this reaction proceeds without the use of a cross-over experiment.

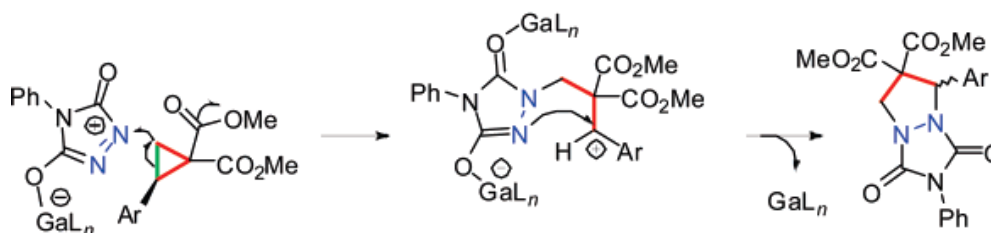
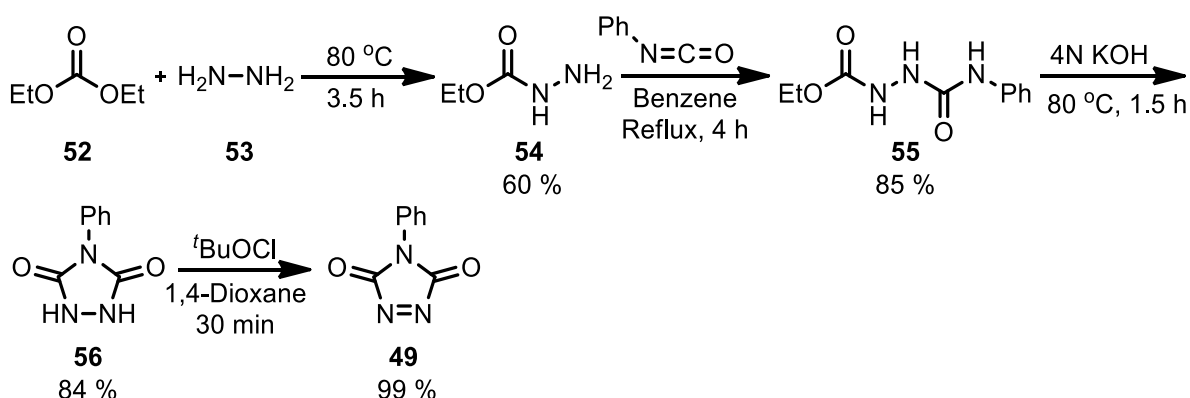

Figure 3.1 Proposed mechanism for the cycloaddition of DA cyclopropane with *cis*-diazene

PTAD was synthesized according to Scheme 3.5 for use in a cross-over experiment and also to generating standards used to analyze the reaction mixture.



Scheme 3.5 Synthesis of PTAD

The cycloaddition of DA cyclopropanes with *cis*-diazenes was investigated so that it may be applied to understanding and advancing the nitrosoarene chemistry if experimental evidence suggests similarities. Possible reaction mechanisms that accounts for both products are shown in Scheme 3.6 and 3.7, demonstrating a possible resemblance to the cycloaddition of DA cyclopropanes with nitrosoarene mechanism. The first mechanism shows the cycloaddition leading to the minor product operating through a step-wise sequence.

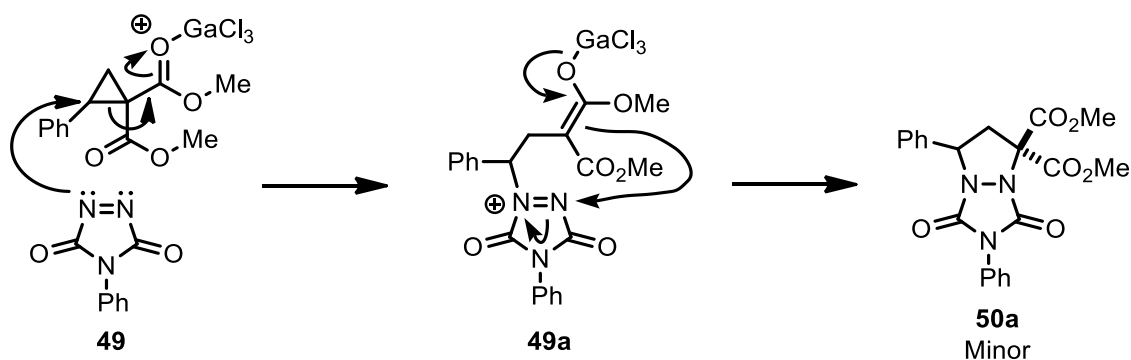

Scheme 3.6 Proposed mechanism for the formation of minor product **50a**

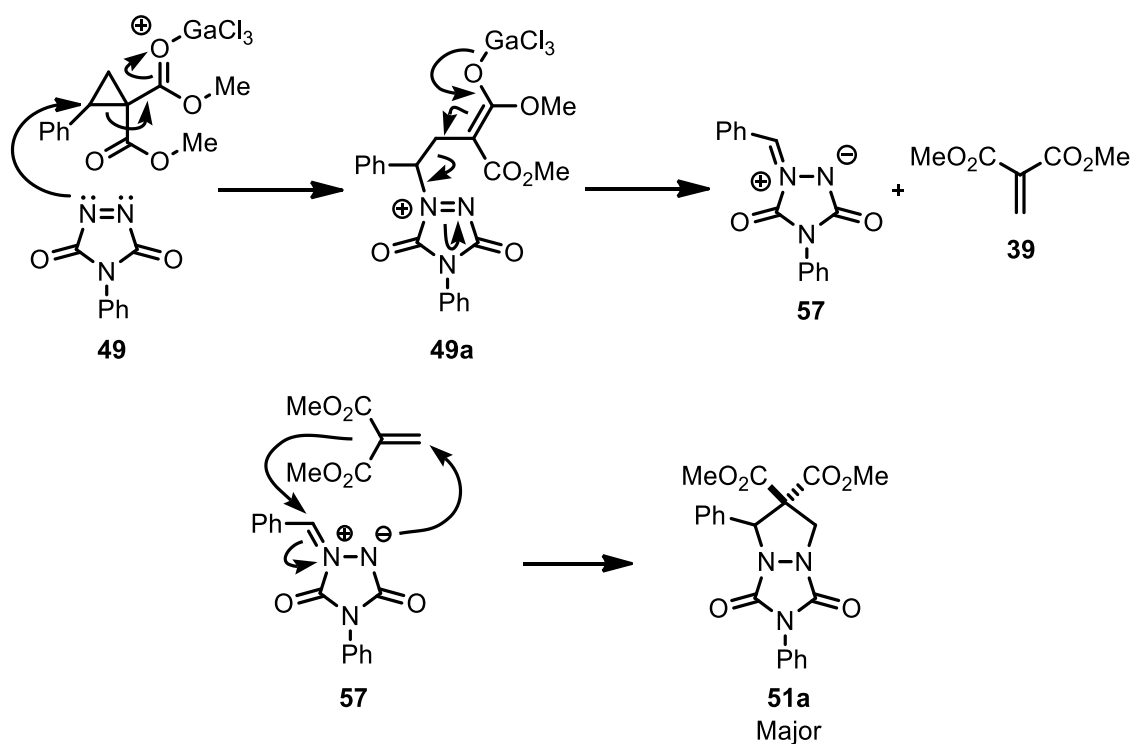

Scheme 3.7 Proposed mechanism for the formation of major product **51a**

Co-ordination of $\text{Yb}(\text{OTf})_3$ to the di-ester group on the cyclopropane may allow for a nucleophilic ring opening attack from a nitrogen in PTAD. The mechanism in scheme 3.6 shows formation of the minor product going through a step-wise cyclization, once the acyclic zwitterionic intermediate is formed. Because the presented cyclization is going through a 5-Endo-Trig reaction,

which is disallowed according to Baldwin's rules, the cyclization may be going through a concerted cycloaddition. Scheme 3.7 and 3.8 illustrate that production of the major product may occur through the formation of an azomethine imine intermediate (**57**).

The formation of azomethine imines through the reaction of DA cyclopropanes with *cis*-diazenes has been of interest in the Pagenkopf group and experimental evidence supporting this theory would be of interest not only for understanding the reaction, but in the future development of new reaction types and reaction partners with DA cyclopropanes.

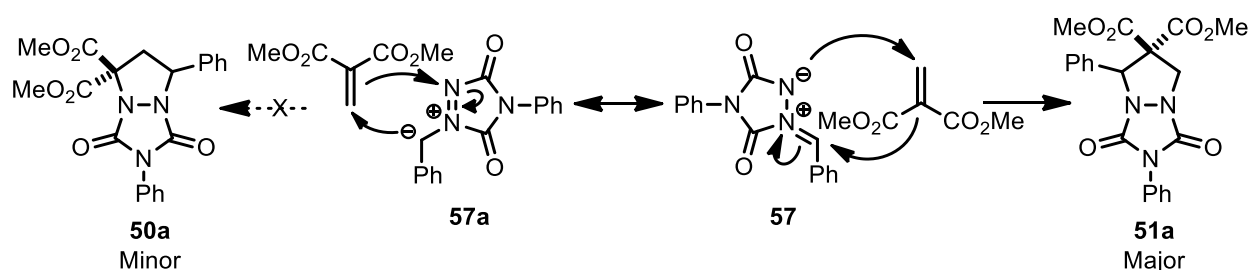

Scheme 3.8 Formation of the two different pyrazolidine *regio*-isomers

Major product **51a** must be coming from azomethine imine **57**, which would have a slightly higher degree of stability or population in comparison to the resonance structure **57a** (Scheme 3.8). The resonance structure, in which the negative charge ends up on nitrogen instead of carbon, would be the more favoured intermediate (**57**) and would therefore contribute to the major product, which is observed to be the case. A resonance structure that places a negative charge on carbon of the azomethine imine (**57a**) is possible, but is not considered to be a nucleophilic centre based on the *regio*-selectivity of other observed azomethine imine reactions. It is therefore highly unlikely that the minor product would be occurring through this type of pathway, and is most likely the result of a formal [3+2] cycloaddition with azomethine imine **57**.

This mode of reactivity would require only one equivalent of DA cyclopropane to one equivalent of the *cis*-diazene because the α,β -unsaturated di-ester may be incorporated into the product. This is slightly different than the nitrosoarene reaction with DA cyclopropanes, because the α,β -unsaturated di-ester is just a by-product and is not incorporated into the tetrahydro-1,2-oxazine product. It is worth determining if the minor product is formed from incorporation of the α,β -unsaturated di-ester unit, or if it is simply a straight-forward cyclization as presented in scheme

2.6. The use of a cross-over experiment would be of great benefit in helping to answer how the two different *regio*-isomers are formed.

Understanding the different ways that DA cyclopropanes react with various dipolarophiles has been undertaken with the hope of developing better and more efficient methods of generating diverse heterocycles. Developing reactions that are able to insert different functional groups into the C(2)-C(3) bond of the cyclopropane ring would have many advantages, and understanding this rare type of reactivity is currently being investigated with the use of cross-over experiments. Being able to open the cyclopropane ring in a controlled manner that allows for different regio-isomers to form is attractive and expands the use of DA cyclopropanes in synthetic chemistry.

3.3.1 Cross-over Experiment #3

Two different cyclopropanes were used as starting material and reacted with PTAD under GaCl₃ catalytic conditions (Scheme 3.9). The production of a cross-over based pyrazolidine product would give information about how this reaction mechanism is happening. If results show the presence of a pyrazolidine product, in which cross-over has occurred, then the reaction may be taking place in a way that is similar to the cycloaddition of DA cyclopropanes with nitrosoarenes reaction.

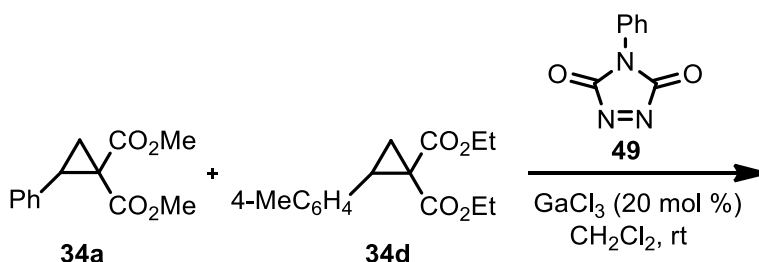

Scheme 3.9 Cross-over experiment of DA cyclopropanes with *cis*-diazene

The four products shown in Figure 3.2 are expected to be in the reaction mixture of the cross-over experiment. These products would arise from the known reactivity of the two DA cyclopropanes reacting with PTAD, and show no crossing-over.

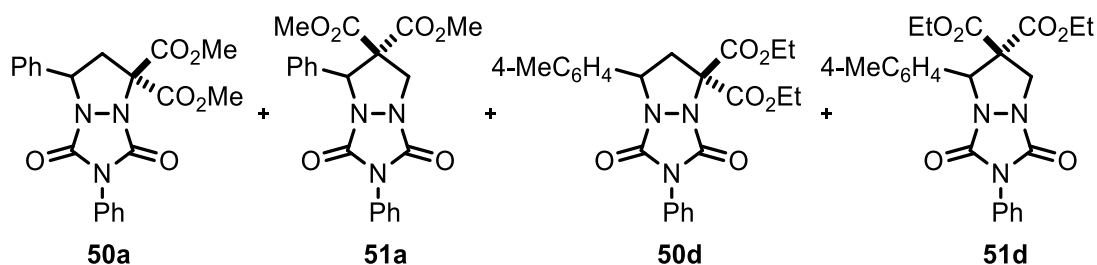

Figure 3.2 Expected products from the cross-over experiment

If additional products are formed, showing that cross-over had occurred, then this provides mechanistic information that would be helpful in generating a theoretical mechanism with supporting evidence. Formation of any of the products shown in Figure 3.3 would be the result of a cross-over event happening in the reaction.

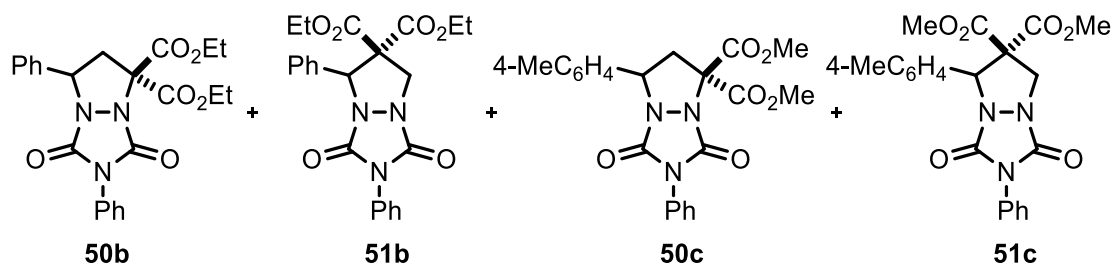
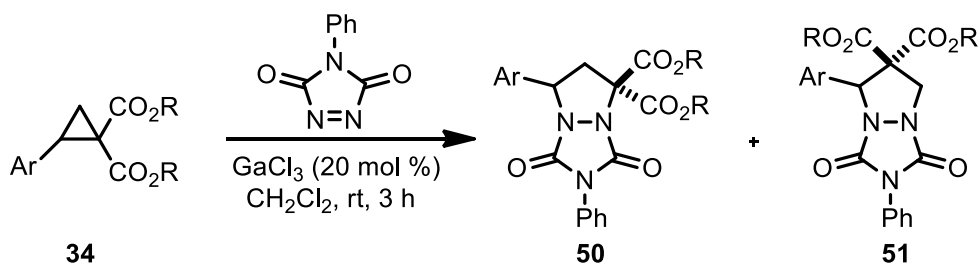

Figure 3.3 Proposed cross-over based products from the cross-over experiment

If DA cyclopropanes react with nitrosoarenes and *cis*-diazenes in a similar fashion, in which a nitrogen-heteroatom double bond opens up the cyclopropane ring, and can be reinforced with experimental evidence, then other reaction types may be discovered by investigating this mode of reactivity. I synthesized the required pyrazolidine standards individually using the methodology presented in de Meijer's study. Table 3.2 shows the synthesis of 8 pyrazolidine standards, which were then used as authentic standards in cross-over experiment #3.

Table 3.2 Synthesis of pyrazolidine standards

Entry ^a	Cyclopropane	Product	Yield (%) ^b
1	Ar = C ₆ H ₅ , R = Me	50a	13
2	Ar = C ₆ H ₅ , R = Me	51a	20
3	Ar = C ₆ H ₅ , R = Et	50b	19
4	Ar = C ₆ H ₅ , R = Et	51b	22
5	Ar = 4-MeC ₆ H ₄ , R = Me	50c	21
6	Ar = 4-MeC ₆ H ₄ , R = Me	51c	12
7	Ar = 4-MeC ₆ H ₄ , R = Et	50d	12
8	Ar = 4-MeC ₆ H ₄ , R = Et	51d	12

^a Typical reaction conditions: GaCl₃ was added to a solution of cyclopropane (0.21 mmol) and PTAD (0.21 mmol) in CH₂Cl₂ (0.2 mL). Reactions were monitored by TLC. ^b Isolated yield.

A detailed analysis of the products from cross-over experiment #3, as seen in Figure 3.4, was achieved with the use of NMR and GC-MS. After carefully analyzing the reaction mixture of the cross-over experiment, it was revealed that all four expected products were formed and, in addition, two of the cross-over products were also formed, yielding six products in total.

		+		+		+	
Product	50a		51a		50d		51d
Retention Time (min): Standard	17.497		17.073		19.438		19.159
Retention Time (min): Cross-Over Exp.	17.572		17.122		19.574		19.267
		+		+		+	
Product	Not Formed		51c		Not Formed		51b
Retention Time (min): Standard	-		18.173		18.297		18.096
Retention Time (min): Cross-Over Exp.	-		18.271		-		18.142

Figure 3.4 Results of cross-over experiment #3

Formation of the cross-over based products provide key mechanistic information that is in agreement with the reaction proceeding via an azomethine imine as illustrated in Scheme 3.7. The azomethine imine can react with either the dimethyl or diethyl α,β -unsaturated ester to yield **51c** or **51b**, respectively. The absence of the other cross-over based products from the reaction mixture is in agreement with the proposed mechanism.

3.3.2 Cross-over Experiment #3 Reversed

To achieve additional supporting evidence, the reaction was run in reverse, starting with cross-over based cyclopropanes (Scheme 3.10) and observing the reaction mixture to see if cross-over was happening in a reproducible event. The reverse cross-over experiment was repeated three times to provide reinforcing data, as seen in Figure 3.5. This generated reproducible results that are in agreement with the original proposed mechanism.

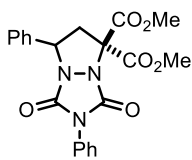
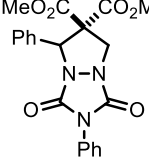
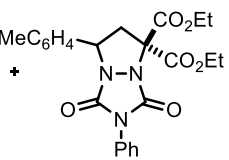
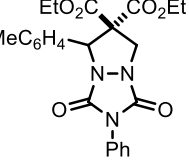
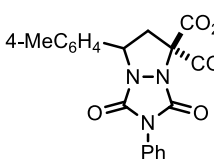
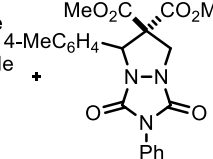
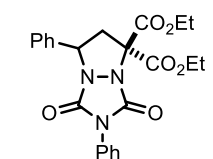
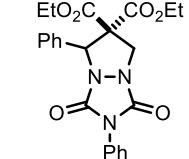
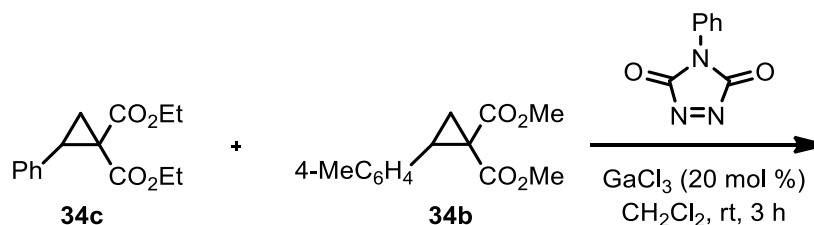

Scheme 3.10 Reversed cross-over experiment of DA cyclopropanes with *cis*-diazenes

Product	50b	51b	50c	51c
Retention Time (min): Cross-Over Exp.	18.2	18.1	18.8	18.3
Run #2	18.230	18.059	18.778	18.230
Run #3	18.196	18.049	18.754	18.196
Product	Not Formed	51d	Not Formed	51a
Retention Time (min): Cross-Over Exp.	50d	19.1	50a	17.1
Run #2	-	19.118	-	17.038
Run #3	-	19.109	-	17.032

Figure 3.5 Results of reversed cross-over experiment #3

The results from cross-over experiments 1 and 3 (Scheme 3.11 and 3.12) show similarities in the reaction of 1,1-cyclopropane diesters with nitrosoarenes and *cis*-diazenes. The overall pattern of reactivity is the same as both reactions led to the production of a 1,3-dipole intermediate. In the case of nitrosoarenes, a nitrone was produced. In the case of *cis*-diazenes, an azomethine imine was produced. In both cases the functional group is a nitrogen-heteroatom double bond, with a lone pair on nitrogen attacking as a nucleophile to open up the activated DA cyclopropane. The

resulting intermediate undergoes fragmentation forming a 1,3-dipole and an α,β -unsaturated diester.

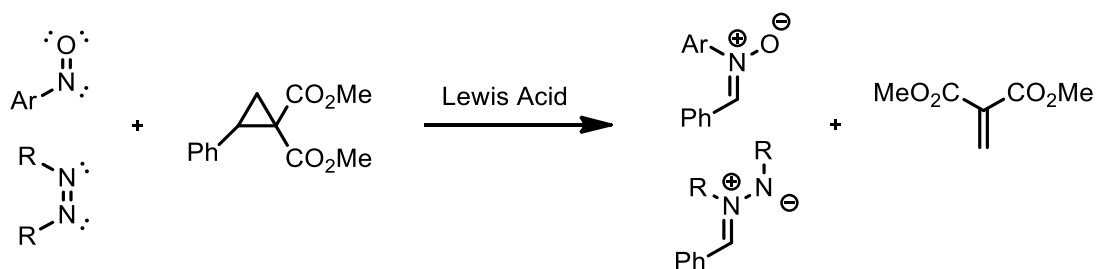

Scheme 3.11 Reaction of nitrosoarenes and *cis*-diazenes with DA cyclopropanes

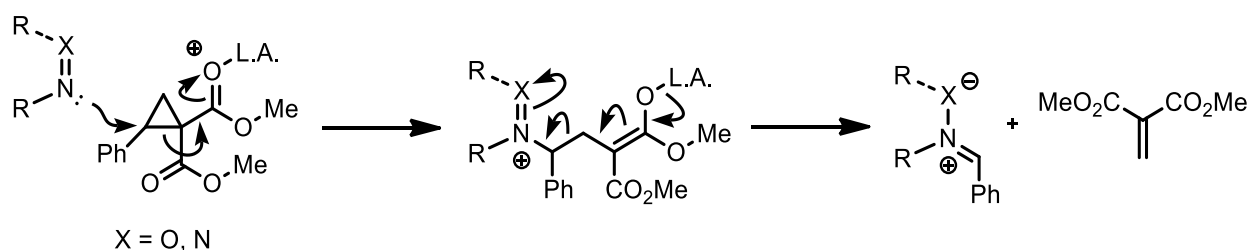

Scheme 3.12 Mechanistic formation of 1,3-dipoles

Additional experimentation may show that other heteroatoms could react in a similar fashion, paving the way for new reactions and other reaction partners for DA cyclopropanes. In the case of nitrogen, which is a Group 5 element, trying elements in the same column such as phosphorus, may lead to new reactions because of similarities in the electronic structure of the two elements.

A potential avenue for investigation could include obtaining a compound with a nitrogen-phosphorus double bond and observing the ability of the sp^2 hybridized nitrogen to undergo nucleophilic opening of a DA cyclopropane ring, followed by fragmentation into a 1,3-dipole and an α,β -unsaturated diester. A proper Lewis Acid would be needed to activate the DA cyclopropane, with the idea of undergoing a reaction similar to Scheme 3.12, except using X = phosphorus.

Another experiment could attempt trying elements in the same column as oxygen, such as sulfur. Obtaining a compound with a nitrogen-sulfur double bond would allow for reactions to study the nucleophilicity of the sp^2 hybridized nitrogen towards the opening of DA cyclopropane rings upon activation by Lewis Acids, similar to Scheme 2.12, except using X = sulfur.

3.4 Experimental

The procedures and conditions were the same as described in section 2.3.

3.5 Supporting Information

General *trans*-Diazene Cycloaddition Procedure

To a solution of cyclopropane (0.21 mmol, 1.0 equiv) and diisopropyl azodicarboxylate (0.29 mmol, 1.4 equiv) in CH₂Cl₂ (0.2 mL) was added a solution of GaCl₃ (0.04 mmol, 0.2 equiv) in CH₂Cl₂ (0.8 mL). After stirring for 3 h, the crude mixture was concentrated and directly loaded onto a packed SiO₂ column. Product was purified by flash chromatography (8:1 hexanes/EtOAc) to afford the corresponding cycloadducts.

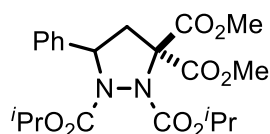

1,2-Diisopropyl 3,3-dimethyl 5-phenylpyrazolidine-1,2,3,3-tetracarboxylate (48a)

The general *trans*-diazene cycloaddition procedure was followed using cyclopropane **34a** (50 mg, 0.21 mmol), diisopropyl azodicarboxylate **47** (59 mg, 0.29 mmol) and GaCl₃ (7 mg, 0.040 mmol) to yield the compound as a yellow oil (53 mg, 58%). R_f 0.22 (3:1 Hexanes:EtOAc); ¹H NMR (400 MHz, CDCl₃) 7.39 (app d, J = 7.8 Hz, 2 H), 7.29 - 7.34 (m, 2 H), 7.22 - 7.26 (m, 1 H), 5.46 (dd, J = 8.2, 3.9 Hz, 1 H), 5.02 (hept, J = 6.3 Hz, 1 H), 4.97 (hept, J = 6.3 Hz, 1 H), 3.82 (s, 3 H), 3.47 (s, 3 H), 3.30 (dd, J = 13.3, 8.2 Hz, 1 H), 2.92 (dd, J = 13.3, 3.9 Hz, 1 H), 1.24 - 1.30 (m, 12 H); ¹³C NMR (100 MHz, CDCl₃) 168.8, 166.5, 156.9, 153.3, 139.5, 128.3, 127.3, 125.8, 72.4, 70.8, 70.5, 61.2, 53.4, 53.0, 44.7, 22.1, 21.9; HRMS C₂₁H₂₈N₂O₈ Calculated = 436.1846, Found = 436.1841

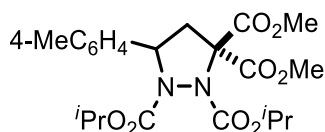

1,2-Diisopropyl 3,3-dimethyl 5-p-tolylpyrazolidine-1,2,3,3-tetracarboxylate (48b)

The general *trans*-diazene cycloaddition procedure was followed using cyclopropane **34b** (55 mg, 0.22 mmol), diisopropyl azodicarboxylate **47** (63 mg, 0.31 mmol) and GaCl₃ (7 mg, 0.040 mmol) to yield the compound as a yellow oil (50 mg, 50%). R_f 0.25 (3:1 Hexanes:EtOAc); ¹H NMR (400 MHz, CDCl₃) 7.27 (app d, J = 8.2 Hz, 2 H), 7.12 (app d, J = 8.2 Hz, 2 H), 5.40 (dd, J = 8.2, 4.3 Hz, 1 H), 5.01 (hept, J = 6.3 Hz, 1 H), 4.98 (hept, J = 6.3 Hz, 1 H), 3.82 (s, 3 H), 3.51 (s, 3 H), 3.27 (dd, J = 13.3, 8.2 Hz, 1 H), 2.90 (dd, J = 13.3, 4.3 Hz, 1 H), 2.32 (s, 3 H), 1.24 - 1.30 (m, 12 H); ¹³C NMR (100 MHz, CDCl₃) 168.8, 166.4, 156.9, 153.4, 136.9, 136.5, 129.0, 125.8, 72.5, 70.7, 70.5, 61.0, 53.4, 53.0, 44.7, 22.1, 21.9; HRMS C₂₂H₃₀N₂O₈ Calculated = 450.2002, Found = 450.1999

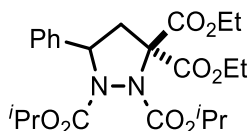

3,3-Diethyl 1,2-diisopropyl 5-phenylpyrazolidine-1,2,3,3-tetracarboxylate (48c)

The general *trans*-diazene cycloaddition procedure was followed using cyclopropane **34c** (50 mg, 0.19 mmol), diisopropyl azodicarboxylate **47** (55 mg, 0.27 mmol) and GaCl₃ (7 mg, 0.040 mmol) to yield the compound as a yellow oil (20 mg, 23%). R_f 0.30 (3:1 Hexanes:EtOAc); ¹H NMR (400 MHz, CDCl₃) 7.38 - 7.42 (m, 2 H), 7.29 - 7.33 (m, 2 H), 7.22 - 7.25 (m, 1 H), 5.50 (dd, J = 8.2, 3.5 Hz, 1 H), 5.02 (hept, J = 6.3 Hz, 1 H), 4.98 (hept, J = 6.3 Hz, 1 H), 4.29 (dddd, J = 7.0, 7.0, 7.0, 10.5 Hz, 2 H), 3.90 (dddd, J = 7.2, 7.2, 7.2, 10.8 Hz, 2 H), 3.33 (dd, J = 13.3, 8.6 Hz, 1 H), 2.90 (dd, J = 13.3, 3.1 Hz, 1 H), 1.24 - 1.34 (m, 15 H), 0.91 (t, J = 7.0 Hz, 3 H); ¹³C NMR (100 MHz, CDCl₃) 168.2, 166.2, 156.9, 153.1, 139.7, 128.3, 127.2, 125.8, 72.3, 70.8, 70.4, 62.4, 62.1, 61.2, 44.5, 22.1, 21.9, 21.7, 14.0, 13.3; HRMS C₂₃H₃₂N₂O₈ Calculated = 464.2159, Found = 464.2167

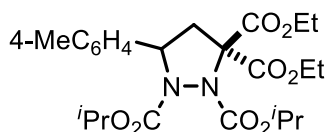

3,3-Diethyl 1,2-diisopropyl 5-(p-tolyl)pyrazolidine-1,2,3,3-tetracarboxylate (48d)

The general *trans*-diazene cycloaddition procedure was followed using cyclopropane **34d** (50 mg, 0.18 mmol), diisopropyl azodicarboxylate **47** (51 mg, 0.25 mmol) and GaCl₃ (6 mg, 0.036 mmol) to yield the compound as a yellow oil (45 mg, 52%). R_f 0.31 (3:1 Hexanes:EtOAc); ¹H NMR (400 MHz, CDCl₃) 7.28 (app d, J = 8.2 Hz, 2 H), 7.11 (app d, J = 8.2 Hz, 2 H), 5.45 (dd, J = 8.2, 3.5 Hz, 1 H), 5.01 (hept, J = 6.3 Hz, 1 H), 4.97 (hept, J = 6.3 Hz, 1 H), 4.28 (dddd, J = 7.0, 7.0, 7.0, 10.5 Hz, 2 H), 3.93 (dddd, J = 7.2, 7.2, 7.2, 10.8 Hz, 2 H), 3.29 (dd, J = 13.3, 8.2 Hz, 1 H), 2.88 (dd, J = 13.3, 3.5 Hz, 1 H), 2.31 (s, 3 H), 1.23 - 1.34 (m, 15 H), 0.95 (t, J = 7.0 Hz, 3 H); ¹³C NMR (100 MHz, CDCl₃) 168.2, 166.2, 156.9, 153.2, 136.8, 136.7, 128.9, 125.8, 72.4, 70.7, 70.3, 62.4, 62.2, 61.0, 44.5, 22.1, 21.9, 21.0, 14.0, 13.3; HRMS C₂₄H₃₄N₂O₈ Calculated = 478.2315, Found = 478.2321

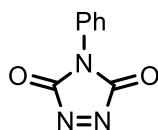

(PTAD) 4-Phenyl-1,2,4-triazoline-3,5-dione (49)

tert-Butyl hypochlorite (130 mg, 1.2 mmol, 1.1 equiv) was added drop wise with stirring to a solution of 4-phenyl-1,2,4-triazolidine-3,5-dione (200 mg, 1.1 mmol, 1.0 equiv) in 1,4-dioxane (5 mL). After 30 min the solvent was removed under reduced pressure keeping the temp below 40°C to yield the product as a red solid (200 mg, 99%). ¹H NMR (400 MHz, CDCl₃) 7.46 - 7.59 (m, 5 H); ¹³C NMR (100 MHz, CDCl₃) 129.9, 129.5, 123.9

General *cis*-Diazene Cycloaddition Procedure

To a solution of cyclopropane (0.85 mmol, 1.0 equiv) and PTAD (1.7 mmol, 2.0 equiv) in CH₂Cl₂ (4.0 mL) was added a solution of GaCl₃ (0.17 mmol, 0.2 equiv) in CH₂Cl₂ (1.0 mL). After stirring for 3 h, the crude mixture was concentrated and directly loaded onto a packed SiO₂ column. Product was purified by flash chromatography (8:1 hexanes/EtOAc) to afford the corresponding cycloadducts.

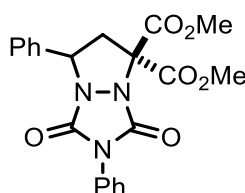

Dimethyl 1,3-dioxo-2,7-diphenyltetrahydropyrazolo[1,2-a][1,2,4]triazole-5,5(1H)-dicarboxylate (**50a**)

The general *cis*-diazene cycloaddition procedure was followed using cyclopropane **34a** (200 mg, 0.85 mmol), *cis*-diazene **49** (298 mg, 1.7 mmol) and GaCl₃ (30 mg, 0.17 mmol) to yield the compound as a white solid (45 mg, 13%). R_f 0.40 (3:1 Hexanes:EtOAc); ¹H NMR (400 MHz, CDCl₃) 7.51 - 7.55 (m, 2 H), 7.33 - 7.47 (m, 8 H), 5.19 (dd, J = 9.0, 7.4 Hz, 1 H), 3.92 (s, 3 H), 3.87 (s, 3 H), 3.28 (d, J = 3.1 Hz, 1 H), 3.25 (d, J = 5.1 Hz, 1 H); ¹³C NMR (100 MHz, CDCl₃) 167.0, 165.7, 153.6, 136.6, 131.5, 129.1, 128.7, 128.3, 126.2, 125.7, 70.7, 59.3, 54.4, 54.0, 46.9; HRMS C₂₁H₁₉N₃O₆ Calculated = 409.1274, Found = 409.1264

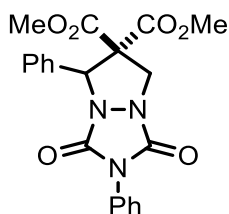

Dimethyl 1,3-dioxo-2,5-diphenyltetrahydropyrazolo[1,2-a][1,2,4]triazole-6,6(1H)-dicarboxylate (51a)

The general *cis*-diazene cycloaddition procedure was followed using cyclopropane **34a** (200 mg, 0.85 mmol), *cis*-diazene **49** (298 mg, 1.7 mmol) and GaCl₃ (30 mg, 0.17 mmol) to yield the compound as a white solid (71 mg, 20%). R_f 0.45 (3:1 Hexanes:EtOAc); ¹H NMR (400 MHz, CDCl₃) 7.48 - 7.50 (m, 4 H), 7.32 - 7.42 (m, 6 H), 5.85 (s, 1 H), 4.46 (d, J = 13.3 Hz, 1 H), 4.28 (d, J = 13.3 H, 1 H), 3.81 (s, 3 H), 3.47 (s, 3 H); ¹³C NMR (100 MHz, CDCl₃) 169.7, 164.8, 156.6, 156.3, 134.9, 131.6, 129.2, 129.1, 128.7, 128.5, 127.3, 126.0, 66.0, 65.3, 54.1, 52.8, 49.8; HRMS C₂₁H₁₉N₃O₆ Calculated = 409.1274, Found = 409.1264

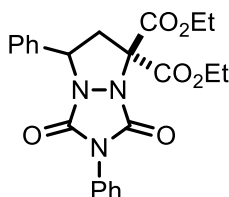

Diethyl 1,3-dioxo-2,7-diphenyltetrahydropyrazolo[1,2-a][1,2,4]triazole-5,5(1H)-dicarboxylate (50b)

The general *cis*-diazene cycloaddition procedure was followed using cyclopropane **34c** (50 mg, 0.19 mmol), *cis*-diazene **49** (67 mg, 0.38 mmol) and GaCl₃ (7 mg, 0.040 mmol) to yield the compound as a white solid (16 mg, 19%). R_f 0.60 (1:1 Hexanes:EtOAc); ¹H NMR (600 MHz, CDCl₃) 7.51 - 7.54 (m, 2 H), 7.43 - 7.45 (m, 4 H), 7.39 - 7.41 (m, 2 H), 7.33 - 7.36 (m, 2 H), 5.16 (dd, J = 9.4, 7.6 Hz, 1 H), 4.37 (dddd, J = 7.0, 7.0, 7.0, 10.5 Hz, 2 H), 4.33 (q, J = 7.0 Hz, 2 H), 3.27 (dd, J = 13.5, 7.6 Hz, 1 H), 3.25 (dd, J = 13.5, 8.8 Hz, 1 H), 1.33 (t, J = 7.0 Hz, 3 H), 1.31 (t, J = 7.0 Hz, 3 H); ¹³C NMR (100 MHz, CDCl₃) 166.6, 165.1, 153.5, 153.2, 136.8, 131.6, 129.1, 129.0, 128.7, 128.2, 126.2, 125.7, 70.9, 63.8, 63.3, 59.2, 46.8, 14.0, 13.9; HRMS C₂₃H₂₃N₃O₆ Calculated = 437.1587, Found = 437.1582

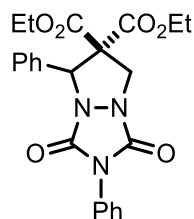

Diethyl 1,3-dioxo-2,5-diphenyltetrahydropyrazolo[1,2-a][1,2,4]triazole-6,6(1H)-dicarboxylate (51b)

The general *cis*-diazene cycloaddition procedure was followed using cyclopropane **34c** (50 mg, 0.19 mmol), *cis*-diazene **49** (67 mg, 0.38 mmol) and GaCl₃ (7 mg, 0.040 mmol) to yield the compound as a white solid (18 mg, 22%). R_f 0.70 (1:1 Hexanes:EtOAc); ¹H NMR (600 MHz, CDCl₃) 7.45 - 7.51 (m, 4 H), 7.35 - 7.40 (m, 6 H), 5.84 (s, 1 H), 4.47 (d, J = 12.9 Hz, 1 H), 4.31 (d, J = 12.9 Hz, 1 H), 4.23 - 4.31 (m, 2 H), 3.99 (dddd, J = 7.3, 7.3, 7.3, 10.9 Hz, 1 H), 3.83 (dddd, J = 7.0, 7.0, 7.0, 10.5 Hz, 1 H), 1.25 (t, J = 7.0 Hz, 3 H), 1.07 (t, J = 7.0 Hz, 3 H); ¹³C NMR (100 MHz, CDCl₃) 164.4, 156.5, 135.1, 129.2, 129.0, 128.6, 128.4, 127.5, 125.9, 81.3, 65.9, 63.3, 62.2, 49.8, 13.8, 13.6; HRMS C₂₃H₂₃N₃O₆ Calculated = 437.1587, Found = 437.1591

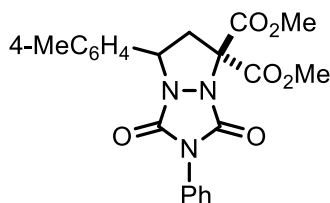

Dimethyl 1,3-dioxo-2-phenyl-7-(p-tolyl)tetrahydropyrazolo[1,2-a][1,2,4]triazole-5,5(1H)-dicarboxylate (50c)

The general *cis*-diazene cycloaddition procedure was followed using cyclopropane **34b** (50 mg, 0.20 mmol), *cis*-diazene **49** (70 mg, 0.40 mmol) and GaCl₃ (7 mg, 0.040 mmol) to yield the compound as a white solid (18 mg, 21%). R_f 0.65 (1:1 Hexanes:EtOAc); ¹H NMR (600 MHz, CDCl₃) 7.50 - 7.53 (m, 2 H), 7.42 - 7.45 (m, 2 H), 7.33 - 7.36 (m, 1 H), 7.32 (app d, J = 7.6 Hz, 2 H), 7.20 (app d, J = 7.6 Hz, 2 H), 5.14 (dd, J = 8.2, 8.2 Hz, 1 H), 3.91 (s, 3 H), 3.87 (s, 3 H), 3.25 (d, J = 8.2 Hz, 2 H), 2.35 (s, 3 H); ¹³C NMR (100 MHz, CDCl₃) 167.0, 165.8, 153.5, 138.6, 131.6, 129.7, 129.0, 128.2, 126.2, 125.7, 70.6, 59.2, 54.3, 54.0, 46.9, 21.1; HRMS C₂₂H₂₁N₃O₆ Calculated = 423.1430, Found = 423.1431

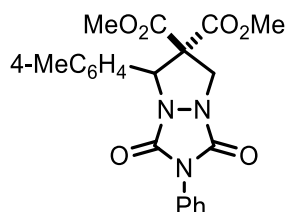

Dimethyl 1,3-dioxo-2-phenyl-5-(p-tolyl)tetrahydropyrazolo[1,2-a][1,2,4]triazole-6,6(1H)-dicarboxylate (51c)

The general *cis*-diazene cycloaddition procedure was followed using cyclopropane **34b** (50 mg, 0.20 mmol), *cis*-diazene **49** (70 mg, 0.40 mmol) and GaCl₃ (7 mg, 0.040 mmol) to yield the compound as a white solid (10 mg, 12%). R_f 0.72 (1:1 Hexanes:EtOAc); ¹H NMR (600 MHz, CDCl₃) 7.48 - 7.49 (m, 4 H), 7.38 - 7.41 (m, 1 H), 7.17 - 7.23 (m, 4 H), 5.81 (s, 1 H), 4.46 (d, J = 12.9 Hz, 1 H), 4.30 (d, J = 12.9 Hz, 1 H), 3.80 (s, 3 H), 3.49 (s, 3 H), 2.34 (s, 3 H); ¹³C NMR (100 MHz, CDCl₃) 169.7, 164.9, 156.2, 139.0, 131.9, 131.6, 129.3, 129.2, 128.4, 127.2, 125.9, 65.9, 65.2, 54.0, 52.8, 49.8, 21.2; HRMS C₂₂H₂₁N₃O₆ Calculated = 423.1430, Found = 423.1431

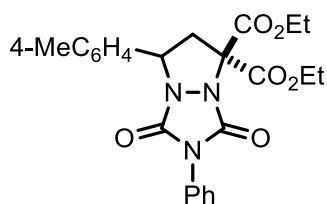

Diethyl 1,3-dioxo-2-phenyl-7-(p-tolyl)tetrahydropyrazolo[1,2-a][1,2,4]triazole-5,5(1H)-dicarboxylate (50d)

The general *cis*-diazene cycloaddition procedure was followed using cyclopropane **34d** (50 mg, 0.18 mmol), *cis*-diazene **49** (63 mg, 0.36 mmol) and GaCl₃ (6 mg, 0.036 mmol) to yield the compound as a white solid (10 mg, 12%). R_f 0.60 (5:1 Et₂O:Pentane); ¹H NMR (400 MHz, CDCl₃) 7.50 - 7.54 (m, 2 H), 7.42 - 7.46 (m, 2 H), 7.33 - 7.37 (m, 3 H), 7.21 (app d, J = 7.8 Hz, 2 H), 5.13 (dd, J = 8.4, 8.4 Hz, 1 H), 4.30 - 4.44 (m, 4 H), 3.24 (d, J = 8.6 Hz, 2 H), 2.35 (s, 3 H), 1.33 (t, J = 7.0 Hz, 3 H), 1.32 (t, J = 7.0 Hz, 3 H); ¹³C NMR (100 MHz, CDCl₃) 166.6, 165.2, 153.5, 153.2, 138.6, 133.7, 131.6, 129.7, 129.0, 128.2, 126.2, 125.7, 70.8, 63.8, 63.3, 59.1, 46.8, 21.2, 14.0, 13.9; HRMS C₂₄H₂₅N₃O₆ Calculated = 451.1743, Found = 451.1733

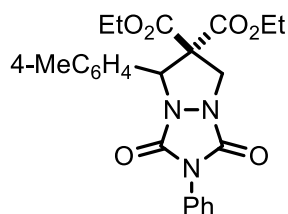

Diethyl 1,3-dioxo-2-phenyl-5-(p-tolyl)tetrahydropyrazolo[1,2-a][1,2,4]triazole-6,6(1H)-dicarboxylate (51d)

The general *cis*-diazene cycloaddition procedure was followed using cyclopropane **34d** (50 mg, 0.18 mmol), *cis*-diazene **49** (63 mg, 0.36 mmol) and GaCl₃ (6 mg, 0.036 mmol) to yield the compound as a white solid (10 mg, 12%). R_f 0.70 (5:1 Et₂O:Pentane); ¹H NMR (400 MHz, CDCl₃) 7.45 - 7.52 (m, 4 H), 7.34 - 7.41 (m, 1 H), 7.23 - 7.25 (m, 2 H), 7.16 - 7.18 (m, 2 H), 5.81 (s, 1 H), 4.46 (d, J = 13.3 Hz, 1 H), 4.23 - 4.31 (m, 3 H), 3.98 - 4.06 (m, 1 H), 3.80 - 3.88 (m, 1 H), 2.34 (s, 3 H), 1.25 (t, J = 7.0 Hz, 3 H), 1.10 (t, J = 7.2 Hz, 3 H); ¹³C NMR (100 MHz, CDCl₃) 169.4, 164.5, 156.5, 156.2, 138.9, 132.0, 131.6, 129.3, 129.2, 128.4, 127.3, 125.9, 120.7, 65.7, 65.4, 63.3, 62.2, 49.8, 21.2, 13.9, 13.6; HRMS C₂₄H₂₅N₃O₆ Calculated = 451.1743, Found = 451.1733

Chapter 4 - Cycloadditions of Donor-Acceptor Cyclobutanes with *cis*-Diazenes

4.1 Introduction

Cyclobutanes have been utilized for various synthetic uses such as ring expansions,²³ metal-catalyzed activation of the carbon-carbon bonds,²⁴ and Baeyer Villiger oxidations.²⁵ Because of the unique properties present in cyclobutanes, such as a highly strained ring system, they have been modified into Donor-Acceptor (DA) cyclobutanes in a similar way to DA cyclopropanes. Because the cyclobutane ring system contains four carbon atoms, a 1,4-dipole equivalent (**59**) may be generated under the appropriate conditions as seen in Scheme 4.1.

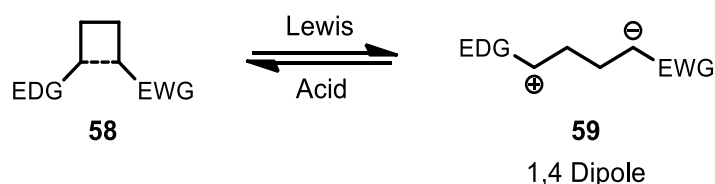

Scheme 4.1 Reactivity of DA cyclobutanes

The use of DA cyclobutanes has received less attention than DA cyclopropanes, with the use of DA cyclobutanes starting around 1986.²⁶ This work later led to the application of DA cyclobutanes in cycloaddition chemistry with seminal work done by Saigo in 1991.²⁷ Saigo reported that amino-activated cyclobutane mono-ester (**60**) reacted with aldehydes or ketones when treated with TiCl_4 to furnish tetrahydropyrans (**62**) in moderate yields and poor diastereoselectivity (Scheme 4.2).

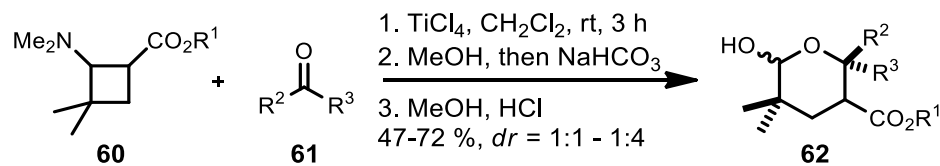

Scheme 4.2 Cycloaddition of DA cyclobutane with aldehydes or ketones

4.1.1 Alkoxy-Activated Cyclobutane Diesters

The Pagenkopf group began experimenting with alkoxy-activated cyclobutane diesters in 2010 because of the similarities to DA cyclopropanes, which have been a focus of interest in the group.²⁸ Reacting DA cyclobutanes with various dipolarophiles began with first with imines, which was followed by aldehydes. Further work included reacting DA cyclobutanes with acetylenes and nitrones (Scheme 4.3).

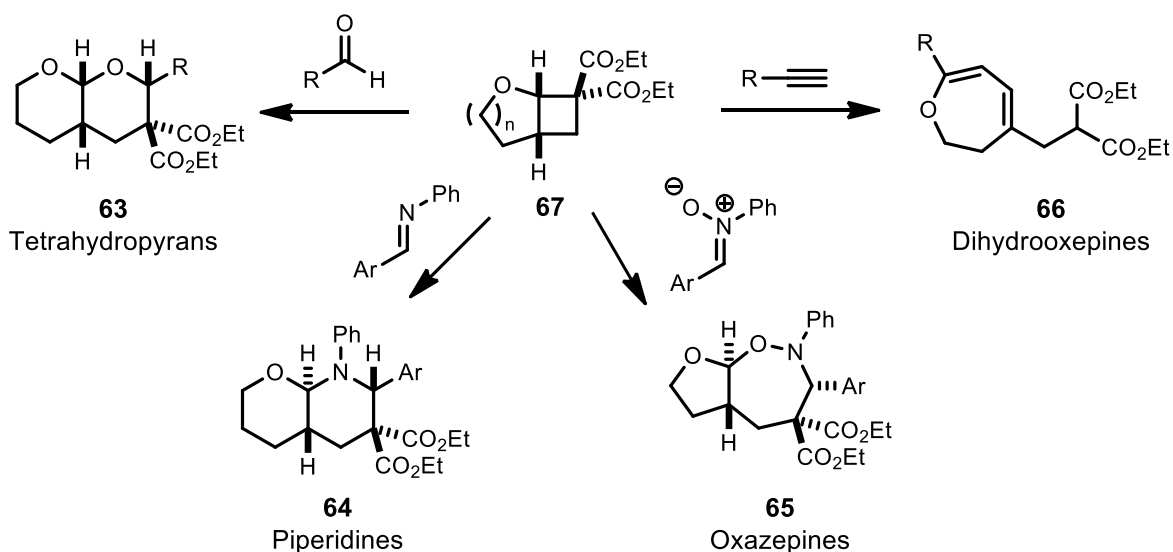

Scheme 4.3 Pagenkopf research of DA cyclobutanes

Under Yb(OTf)₃ catalysis, DA cyclobutanes undergo a formal [4+2] cycloaddition with imines to form piperidines (**64**) in a stereoselective manner. A similar type of formal [4+2] cycloaddition is also possible when aldehydes are used as the dipolarophile, and produce tetrahydropyrans (**63**) again in a stereoselective manner.²⁹ Both of these reactions were discovered in 2010 and it was quickly realized that other dipolarophiles would react in a similar way. In 2011, the formal [4+3] cycloaddition between DA cyclobutanes and nitrones was discovered. This reaction led to oxazepines (**65**) with stereochemistry that can be controlled based on reaction conditions.³⁰ In the same year it was also discovered that terminal alkynes reacted with DA cyclobutanes in the presence of BF₃·OEt₂ as the Lewis acid to generate dihydrooxepines (**66**).³¹

4.1.2 Synthesis of DA Cyclobutanes

To begin exploring the possibility of cycloadditions occurring between DA cyclobutanes and *cis*-diazenes, it was necessary to work with the appropriate starting materials. The Pagenkopf group's success with alkoxy-activated cyclobutane diesters in other cycloaddition reactions determined them to be a good choice for the DA cyclobutane. The required alkoxy-activated cyclobutane diester was synthesized through a two-step procedure that began with a Knoevenagel condensation of diethyl malonate (**68**) with paraformaldehyde to generate the highly reactive methyldiene malonate (**69**). The malonate was then treated with dihydrofuran (**70**) under $\text{Zn}(\text{OTf})_2$ catalyzed conditions to afford the desired DA cyclobutane (**67**) as seen in Scheme 4.4.

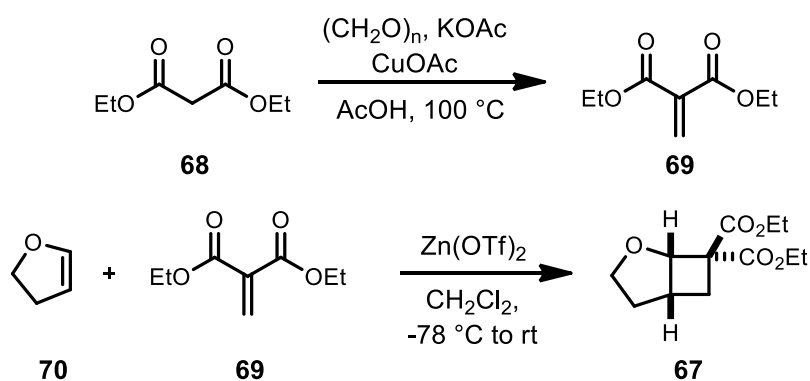

Scheme 4.4 Two-step synthesis of DA cyclobutanes

4.1.3 Cycloadditions of DA Cyclobutanes with *cis*-Diazenes

Because the Pagenkopf group was already performing cycloadditions with *cis*-diazenes for DA cyclopropanes, I naturally progressed to trying the same diazene (PTAD) with DA cyclobutanes. PTAD was selected as a desirable *cis*-diazene to work with because of its stability and long shelf-life, and it can be easily synthesized using a straightforward synthetic route. A common problem with other *cis*-diazenes is thermal instability leading to decomposition at room temperature. Finding alternative *cis*-diazenes to undergo cycloaddition reactions with DA cyclobutanes was made difficult due to their instability at room temperature and the limited commercial availability of other *cis*-diazenes.

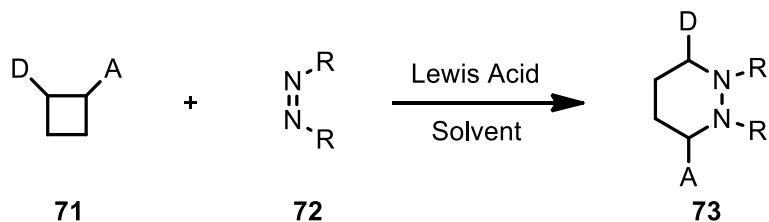

Scheme 4.5 General cycloaddition of DA cyclobutanes with *cis*-diazenes

The general reaction is shown in scheme 4.5 and the parent molecule generated is a hexahydropyridazine (**73**). Biological assays have shown hexahydropyridazines to exhibit moderate levels of anesthetic, antihistaminic, and anticonvulsive activity.³² When PTAD is used as the *cis*-diazene, a 5,6,5-ring system is generated through a formal [4+2] cycloaddition with DA cyclobutane (**67**) as seen in Scheme 4.6. These products may potentially serve as a starting point for the synthesis of other useful compounds, and also contain functionality to undergo post-modification.

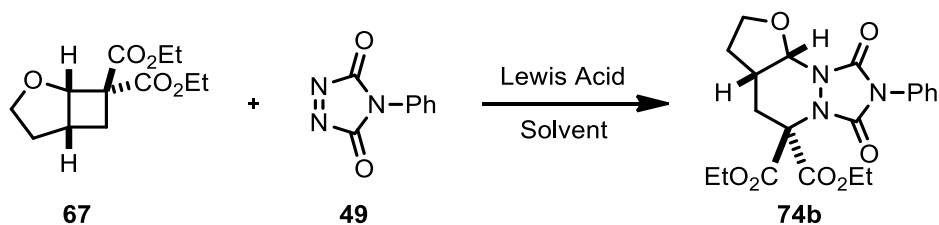

Scheme 4.6 Cycloaddition of DA cyclobutanes with PTAD

4.2 Results and Discussion

After some experimentation, it was discovered that *cis*-diazenes such as PTAD are indeed a compatible reaction partner for DA cyclobutanes. The [4+2] cycloaddition was achieved using a necessary Lewis acid, and both GaCl₃ and Yb(OTf)₃ were successful. Optimization of the reaction conditions led to GaCl₃ being the better choice for a Lewis acid, with the highest yield occurring at 5 mol % catalytic loading (Table 4.1).

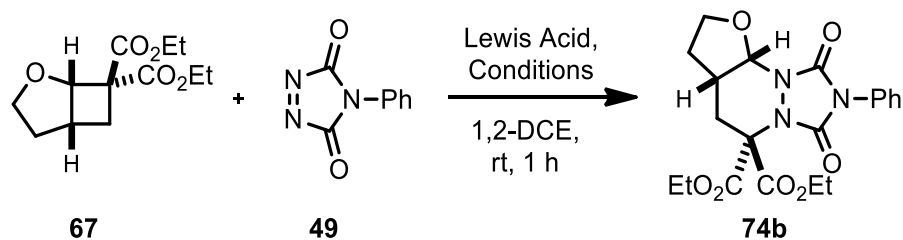
Table 4.1 Cycloaddition of DA cyclobutane with *cis*-diazene

Entry ^a	Cyclobutane (Equivalents)	<i>cis</i> -Diazene (Equivalents)	Lewis Acid	Mol %	Yield (%) ^b
1	1	1	Yb(OTf) ₃	10	38
2	1	1	GaCl ₃	10	41
3	1.5	1	GaCl ₃	10	63
4	2	1	GaCl ₃	10	79
5 ^c	2	1	GaCl ₃	5	92
6 ^d	2	1	GaCl ₃	2	84

^a Typical reaction conditions: To a solution of GaCl₃ in 1,2-DCE (3 mL) at room temperature, was added cyclobutane (0.44 mmol) and nitrosoarene (0.22 mmol). Reactions were monitored by TLC until cyclobutane was consumed. ^b Isolated yield. ^c 20 min reaction time. ^d 90 min reaction time.

The *cis* stereochemistry of product (74c) was deduced from analyzing a crystal structure as seen in Figure 4.1.

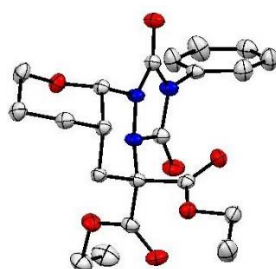
**Figure 4.1** Crystal structure of hexahydropyridazine 74c

4.2.1 Reaction Scope

After obtaining optimal reaction conditions for the cycloaddition, the scope was investigated to see if other DA cyclobutanes were compatible with PTAD. Good yields were obtained using various alkoxy-activated cyclobutane diesters as seen in Figure 4.2.

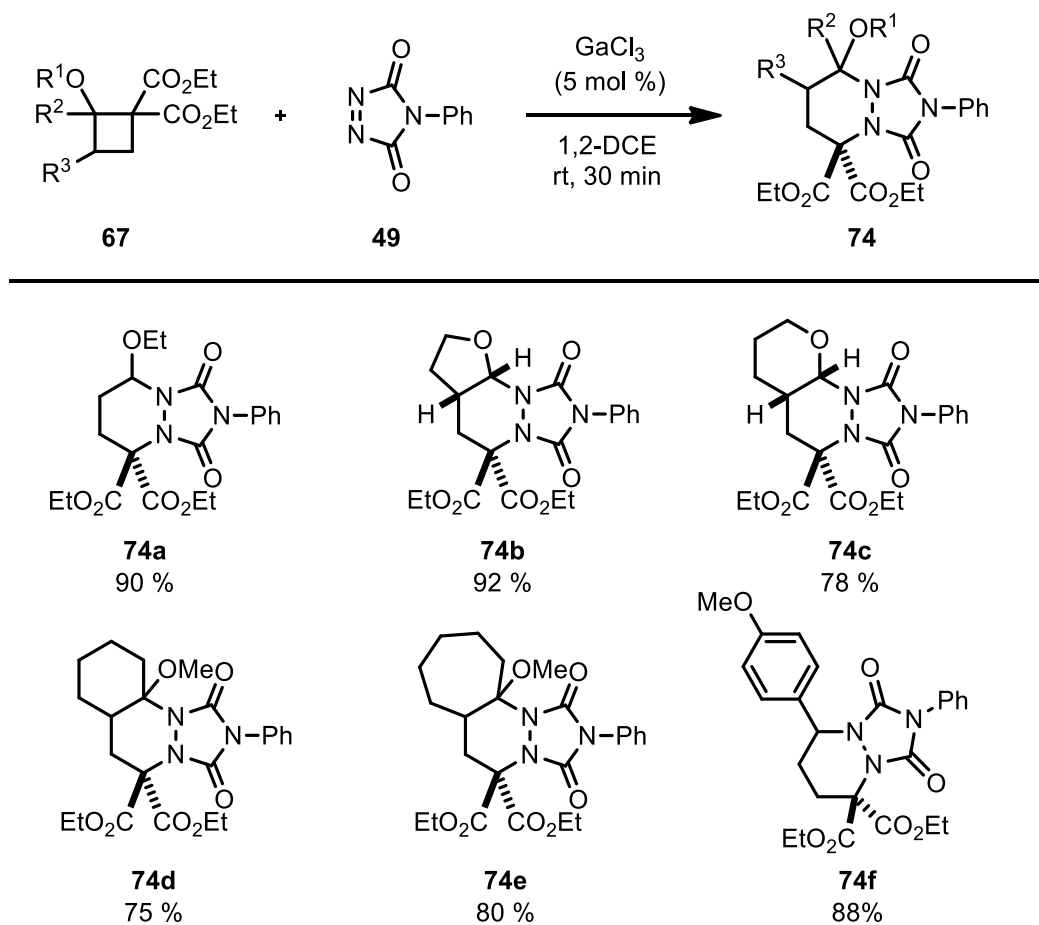
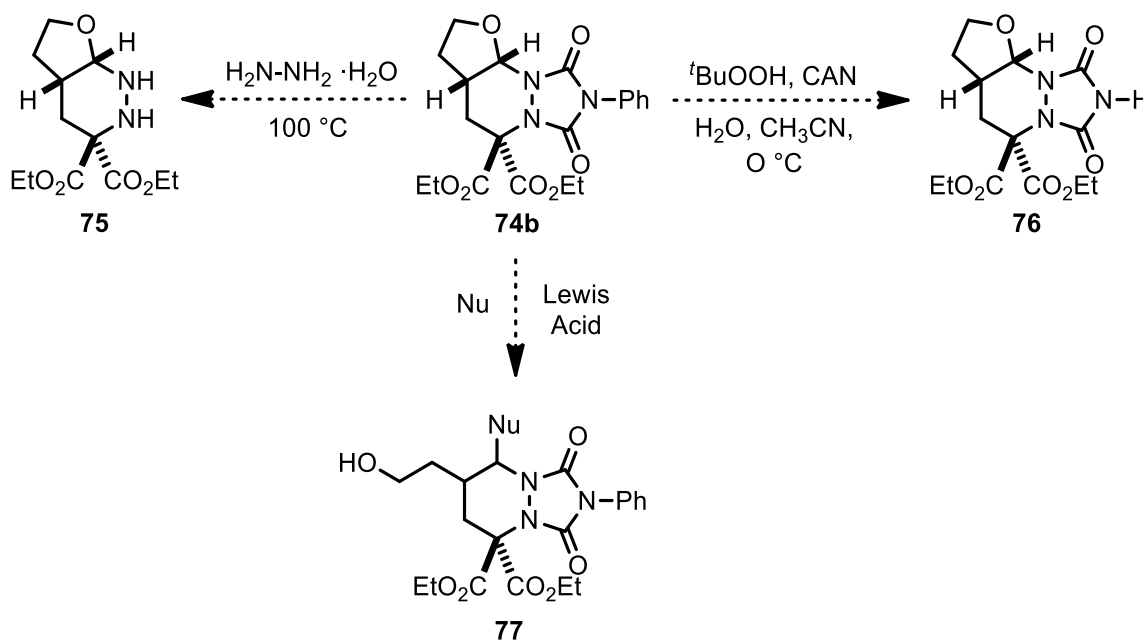

Figure 4.2 Cycloadditions of different DA cyclobutanes with PTAD

Reacting DA cyclobutanes with *trans*-diazenes was attempted but did not result in a cycloaddition. This came as no surprise because of the difference in reactivity between *trans*- and *cis*-diazenes. The difference in reactivity was also observed when working with DA cyclopropanes.

4.3 Post Modification of Hexahydropyridazine Products

The methodology discovered enables easy access to the hexahydropyridazine ring system through an efficient cycloaddition of DA cyclobutanes with *cis*-diazenes. Using specific DA cyclobutanes, the diastereoselectivity can be controlled and can therefore be used in the stereoselective synthesis of hexahydropyridazine systems. These systems contain the appropriate functionality to undergo different post modification reactions (Scheme 4.7). This demonstrates the versatility of the ring system to undergo various transformations to yield different compounds from a single product. The post-modified products can then be potentially useful in the synthesis of other target molecules or serve in other applications.



Scheme 4.7 Potential post modifications of hexahydropyridazine **74b**

4.4 Experimental

The procedures and conditions were the same as described in section 2.3.

4.5 Supporting Information

General Procedure for Cycloaddition of *cis*-Diazene with DA Cyclobutane

To a solution of cyclobutane (0.43 mmol, 2.0 equiv) and PTAD (0.22 mmol, 1.0 equiv) in 1,2-DCE (3 mL) was added GaCl₃ (0.01 mmol, 0.05 equiv) and stirred for 30 min at rt. The mixture was then concentrated after consumption of cyclobutane (as indicated by TLC) and directly loaded onto a packed SiO₂ column. Product was purified by flash chromatography (1:1 hexanes/EtOAc) to afford the corresponding cycloadducts.

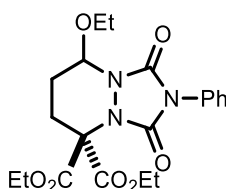

Diethyl 8-ethoxy-1,3-dioxo-2-phenyltetrahydro-1H-[1,2,4]triazolo[1,2-a]pyridazine-5,5(6H)-dicarboxylate (74a)

The general procedure for cycloaddition of *cis*-diazene with DA cyclobutane was followed using cyclobutane (142 mg, 0.58 mmol), *cis*-diazene **49** (50 mg, 0.29 mmol) and GaCl₃ (2.6 mg, 0.015 mmol) to yield the compound as a white solid. (109 mg, 90%). R_f 0.20 (3:1 Hexanes:EtOAc); ¹H NMR (600 MHz, CDCl₃) 7.50 (app d, J = 8.2 Hz, 2 H), 7.45 (app t, J = 7.9 Hz, 2 H), 7.34 - 7.38 (m, 1 H), 5.54 (d, J = 1.8 Hz, 1 H), 4.25 - 4.37 (m, 4 H), 3.62 - 3.70 (m, 2 H), 2.69 (ddd, J = 14.1, 14.1, 4.1 Hz, 1 H), 2.47 - 2.51 (m, 1 H), 2.08 (d, J = 14.1 Hz, 1 H), 1.70 (dddd, J = 14.1, 4.1, 4.1, 4.1 Hz, 1 H), 1.27 - 1.33 (m, 6 H), 1.23 (t, J = 7.0 Hz, 3 H); ¹³C NMR (100 MHz, CDCl₃) 166.2, 165.8, 153.7, 151.0, 131.0, 129.1, 128.3, 125.7, 77.6, 70.4, 65.0, 63.2, 63.0, 26.5, 25.6, 15.0, 14.1, 13.8; HRMS C₂₀H₂₅N₃O₇ Calculated = 419.1693, Found = 419.1699

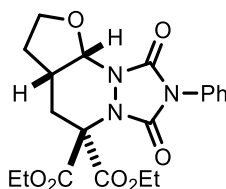

Diethyl 7,9-dioxo-8-phenylhexahydro-2H-furo[2,3-c][1,2,4]triazolo[1,2-a]pyridazine-5,5(3H)-dicarboxylate (74b)

The general procedure for cycloaddition of *cis*-diazene with DA cyclobutane was followed using cyclobutane (141 mg, 0.58 mmol), *cis*-diazene **49** (50 mg, 0.29 mmol) and GaCl₃ (2.6 mg, 0.015 mmol) to yield the compound as a white solid. (111 mg, 92%). R_f 0.50 (1:1 Hexanes:EtOAc); ¹H NMR (400 MHz, CDCl₃) 7.45 - 7.53 (m, 4 H), 7.38 (app t, J = 7.0 Hz, 1 H), 5.78 (d, J = 4.3 Hz, 1 H), 4.29 - 4.37 (m, 4 H), 4.18 - 4.23 (m, 2 H), 4.08 (td, J = 9.4, 2.0 Hz, 1 H), 2.64 (dd, J = 13.3, 5.9 Hz, 1 H), 2.40 - 2.48 (m, 1 H), 2.28 - 2.36 (m, 1 H), 2.24 (dd, J = 13.3, 12.1 Hz, 1 H), 1.90 (ddd, J = 6.6, 6.6, 2.0 Hz, 1 H), 1.34 (t, J = 7.0 Hz, 3 H), 1.32 (t, J = 7.0 Hz, 3 H); ¹³C NMR (100 MHz, CDCl₃) 166.0, 165.6, 153.3, 150.5, 130.9, 129.2, 129.1, 128.4, 125.8, 80.8, 68.9, 66.2, 63.5, 63.1, 32.3, 31.7, 30.2, 14.1, 13.8; HRMS C₂₀H₂₃N₃O₇ Calculated = 417.1536, Found = 417.1530

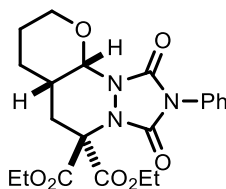

Diethyl 8,10-dioxo-9-phenyloctahydropyrano[2,3-c][1,2,4]triazolo[1,2-a]pyridazine-6,6(2H)-dicarboxylate (74c)

The general procedure for cycloaddition of *cis*-diazene with DA cyclobutane was followed using cyclobutane (149 mg, 0.58 mmol), *cis*-diazene **49** (50 mg, 0.29 mmol) and GaCl₃ (2.6 mg, 0.015 mmol) to yield the compound as a white solid. (97 mg, 78%). R_f 0.48 (1:1 Hexanes:EtOAc); ¹H NMR (400 MHz, CDCl₃) 7.42 - 7.50 (m, 4 H), 7.36 (app t, J = 7.0 Hz, 1 H), 5.29 - 5.32 (m, 1 H), 4.26 - 4.38 (m, 4 H), 4.09 - 4.14 (m, 1 H), 3.65 (td, J = 12.1, 2.3 Hz, 1 H), 2.76 (dd, J = 13.1, 13.1 Hz, 1 H), 2.37 (dd, J = 13.1, 3.7 Hz, 1 H), 1.90 - 1.95 (m, 2 H), 1.81 - 1.88 (m, 2 H), 1.44 (d, J = 12.5 Hz, 1 H), 1.24 - 1.34 (m, 6 H); ¹³C NMR (100 MHz, CDCl₃) 166.3, 165.6, 152.6, 150.7,

131.0, 129.1, 128.3, 125.8, 78.1, 69.6, 67.9, 63.4, 63.0, 30.0, 29.9, 27.1, 19.6, 14.1, 13.8; HRMS $C_{21}H_{25}N_3O_7$ Calculated = 431.1693, Found = 431.1693

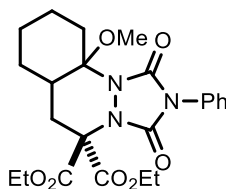

Diethyl 10a-methoxy-1,3-dioxo-2-phenyloctahydro-1H-[1,2,4]triazolo[1,2-a]cinnoline-5,5(6H)-dicarboxylate (74d)

The general procedure for cycloaddition of *cis*-diazene with DA cyclobutane was followed using cyclobutane (165 mg, 0.58 mmol), *cis*-diazene **49** (50 mg, 0.29 mmol) and GaCl₃ (2.6 mg, 0.015 mmol) to yield the compound as a white solid. (99 mg, 75%). R_f 0.21 (3:1 Hexanes:EtOAc); ¹H NMR (400 MHz, CDCl₃) 7.41 - 7.47 (m, 4 H), 7.31 - 7.35 (app tt, J = 7.0, 1.8 Hz, 1 H), 4.89 (dd, J = 4.1 Hz, 1 H), 4.10 - 4.25 (m, 4 H), 3.85 (dd, J = 6.5, 4.1 Hz, 1 H), 3.45 (s, 3 H), 2.82 (dd, J = 15.3, 6.5 Hz, 1 H), 2.78 (dd, J = 15.3, 4.1 Hz, 1 H), 2.29 - 2.33 (m, 1 H), 2.10 - 2.19 (m, 2 H), 1.91 - 1.95 (m, 1 H), 1.66 - 1.70 (m, 2 H), 1.26 (t, J = 7.0 Hz, 3 H), 1.25 (t, J = 7.0 Hz, 3 H); ¹³C NMR (100 MHz, CDCl₃) 170.1, 169.2, 153.4, 152.2, 151.7, 129.0, 128.1, 125.7, 100.2, 64.7, 61.8, 61.5, 54.0, 48.4, 35.9, 31.9, 23.4, 19.0, 14.1; HRMS $C_{23}H_{29}N_3O_7$ Calculated = 459.2006, Found = 460.2090

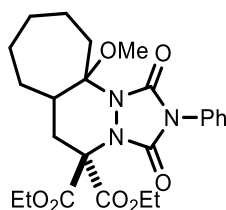

Diethyl 11a-methoxy-1,3-dioxo-2-phenyldecahydrocyclohepta[c][1,2,4]triazolo[1,2-a]pyridazine-5,5(1H)-dicarboxylate (74e)

The general procedure for cycloaddition of *cis*-diazene with DA cyclobutane was followed using cyclobutane (173 mg, 0.58 mmol), *cis*-diazene **49** (50 mg, 0.29 mmol) and GaCl₃ (2.6 mg, 0.015 mmol) to yield the compound as a white solid. (110 mg, 80%). R_f 0.53 (1:1 Hexanes:EtOAc); ¹H

NMR (400 MHz, CDCl₃) 7.48 - 7.50 (m, 2 H), 7.45 (app t, J = 7.9 Hz, 2 H), 7.34 (app t, J = 7.6 Hz, 1 H), 4.58 (app dd, J = 4.5, 2.3 Hz, 1 H), 4.19 - 4.23 (m, 4 H), 3.47 - 3.53 (m, 1 H), 3.34 (s, 3 H), 3.27 (s, 3 H), 2.32 - 2.38 (m, 1 H), 2.03 - 2.08 (m, 1 H), 1.91 - 1.95 (m, 2 H), 1.78 - 1.80 (m, 2 H), 1.53 - 1.65 (m, 5 H), 1.24 - 1.27 (m, 6 H); ¹³C NMR (100 MHz, CDCl₃) 169.6, 169.4, 153.3, 129.1, 128.1, 125.4, 105.0, 62.3, 61.5, 61.0, 51.3, 50.3, 48.6, 41.0, 30.3, 27.5, 25.2, 24.6, 24.5, 21.1, 14.1; HRMS C₂₄H₃₁N₃O₇ Calculated = 473.2162, Found = 473.2165

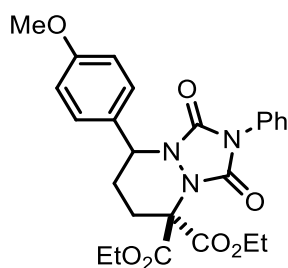

Diethyl 8-(4-methoxyphenyl)-1,3-dioxo-2-phenyltetrahydro-1H-[1,2,4]triazolo[1,2-a]pyridazine-5,5(6H)-dicarboxylate (74f)

The general procedure for cycloaddition of *cis*-diazene with DA cyclobutane was followed using cyclobutane (48 mg, 0.16 mmol), *cis*-diazene **49** (14 mg, 0.08 mmol) and GaCl₃ (0.7 mg, 0.004 mmol) to yield the compound as a white solid. (34 mg, 88%). R_f 0.45 (1:1 Hexanes:EtOAc); ¹H NMR (400 MHz, CDCl₃) 7.39 - 7.47 (m, 5 H), 7.34 (app d, J = 8.6 Hz, 2 H), 6.86 (app d, J = 8.6 Hz, 2 H), 5.11 (dd, J = 11.3, 4.3 Hz, 1 H), 4.20 - 4.31 (m, 4 H), 3.79 (s, 3 H), 3.49 (dd, J = 8.4, 4.5 Hz, 1 H), 2.09 - 2.23 (m, 2 H), 1.80 - 2.04 (m, 2 H), 1.29 (t, J = 7.0 Hz, 6 H); ¹³C NMR (100 MHz, CDCl₃) 169.7, 169.4, 154.1, 129.0, 128.9, 128.1, 125.5, 114.1, 61.9, 59.7, 55.3, 50.7, 29.0, 26.6, 25.0, 14.1; HRMS C₂₅H₂₇N₃O₇ Calculated = 481.1849, Found = 481.1837

Chapter 5 - Conclusions

This thesis has investigated the mechanism of reaction between DA cyclopropanes and nitrosoarenes. The reaction of DA cyclopropanes with azo dicarboxylates was also investigated. These reactions were studied with the use of cross-over experiments. The information learned from these experiments could be used in the development of new reactions. The successful completion of these projects demonstrates the usefulness and versatility of DA cyclopropanes in synthetic organic chemistry.

A breakthrough that was discovered in this thesis included the general pattern of reactivity of nitrogen to open a DA cyclopropane, which undergoes fragmentation and generation of a 1,3-dipole. This reaction type may lead to the discovery of new reactions if further exploration is attempted. This reaction represents a novel way of synthesizing heterocyclic compounds and incorporating new atoms may allow for construction of new heterocycles.

The reaction of DA cyclobutanes with *cis*-diazenes was also accomplished in a highly efficient cycloaddition. The generality of the reaction scope was achieved from the successful coupling of different DA cyclobutanes with *cis*-diazene, PTAD. This project showcased a novel approach to the synthesis of hexahydropyridazine systems. These six-membered ring heterocycles have limited ways to be created, and can now be efficiently synthesized, which demonstrates the usefulness of this chemistry.

References

- ¹ de Meijere, A. *Small Ring Compounds in Organic Synthesis VI*; Springer: Berlin, 2000, 207
- ² Wiberg, K. *Angew. Chem. Int. Ed.* **1986**, *25*, 312-322
- ³ Faust, R. *Angew. Chem. Int. Ed.* **2001**, *40*, 2251–2253
- ⁴ Bartholow, M. Top 200 prescription drugs of 2010. Pharmacy Times Website.
<http://pharmacytimes.com/publications/issue/2010>
- ⁵ Schneider, T. F.; Kaschel, J.; Werz, D. B. *Angew. Chem. Int. Ed.* **2014**, *53*, 5504 – 5523
- ⁶ M. Yu, B. L. Pagenkopf, *Tetrahedron* **2005**, *61*, 321-47
- ⁷ For a review, see: Kobayashi, S.; Jorgensen, K. A. *Cycloaddition Reactions in Organic Synthesis*, WILEY-VCH Verlag GmbH: Weinheim, Germany, 2002.
- ⁸ Heeney, M.; Bailey, C.; Genevicius, K.; Shkunov, M.; Sparrowe, D.; Tierney, S.; Mculloch, I. *J. Am. Chem. Soc.* **2005**, *127*, 1078-1079
- ⁹ Butler, R. N.; Coyne, A. G. *Chem Rev.* **2010**, *110*, 6302-6337
- ¹⁰ Seebach, D. *Angew. Chem. Int. Ed.* **1979**, *18*, 239-336
- ¹¹ Young, I. S.; Kerr, M. A. *Angew. Chem. Int. Ed.* **2003**, *42*, 3023-3026
- ¹² Wanapun, D.; Van Gorp, K. A.; Mosey, N. J.; Kerr, M.A.; Woo, T. K. *Can. J. Chem.* **2005**, *83*, 1752-1767
- ¹³ Young, I. S.; Kerr, M. A. *Org. Lett.* **2004**, *6*, 139-141
- ¹⁴ A. Karadeolian, M. A. Kerr, *J. Org. Chem.* **2007**, *72*, 10251-10253
- ¹⁵ Kang, Y. B.; Sun, X. L.; Tang, Y. *Angew. Chem.* **2007**, *119*, 3992-3995
- ¹⁶ Terano, H.; Takase, S.; Hosoda, J.; Kohsaka, M. *J. Antibiotics*, **1989**, *42*, 145-148
- ¹⁷ Young, I. S.; Kerr, M. A. *J. Am. Chem. Soc.* **2007**, *129*, 1465-1469

-
- ¹⁸ Humenny, W. J.; Kyriacou, P.; Sapeta, K.; Karadeolian, A.; Kerr, M. A. *Angew. Chem. Int. Ed.* **2012**, *51*, 11088-11091
- ¹⁹ Chakrabarty, S.; Chatterjee, I.; Wibbeling, B.; Daniliuc, C. G.; Studer, A. *Angew. Chem.* **2014**, *126*, 6074-6078
- ²⁰ Johansen, M. B.; Kerr, M. A. *Org. Lett.* **2008**, *10*, 3497-3500
- ²¹ Chakrabarty, S.; Chatterjee, I.; Wibbeling, B.; Daniliuc, C. G.; Studer, A. *Angew. Chem. Int. Ed.* **2014**, *53*, 5964-5968
- ²² Korotkov, V. S.; Larionov, O. L.; Hofmeister, A.; Magull, J.; de Meijere, A. *J. Org. Chem.* **2007**, *72*, 7504-7510
- ²³ Trost, B. M.; Yasukata, T. *J. Am. Chem. Soc.* **2001**, *123*, 7162
- ²⁴ Nishimura, T.; Ohe, K.; Uemura, S. *J. Org. Chem.* **2001**, *66*, 1455
- ²⁵ Loop, M.; Paju, A.; Kanger, T.; Pehk, T. *Tetrahedron Lett.* **1996**, *37*, 7583
- ²⁶ Baar, M. R.; Ballesteros, P.; Roberts, B. W. *Tetrahedron Lett.* **1986**, *27*, 2083
- ²⁷ Shimada, S.; Saigo, K.; Nakamura, H.; Hasegawa, M. *Chem. Lett.* **1991**, 1149
- ²⁸ Moustafa, M. M. A. R.; Pagenkopf, B. L. *Org. Lett.* **2010**, *12*, 4732
- ²⁹ Moustafa, M. M. A. R.; Stevens, A. C.; Machin, B. P.; Pagenkopf, B. L. *Org. Lett.* **2010**, *12*, 4736
- ³⁰ Stevens, A. C.; Palmer, C.; Pagenkopf, B. L. *Org. Lett.* **2011**, *13*, 1528
- ³¹ Machin, B. P.; Pagenkopf, B. L. *Synlett* **2011**, 2799
- ³² Khanamiryan, A. K.; Gyulbudagyan, A. L.; Vartanyan, P. S.; Dzhafarov, M. K.; Struchkov, Y. *T. Russ. Chem. Bull.* **1993**, *42*, 496-499

Appendix 1 - NMR Data Chapter 2

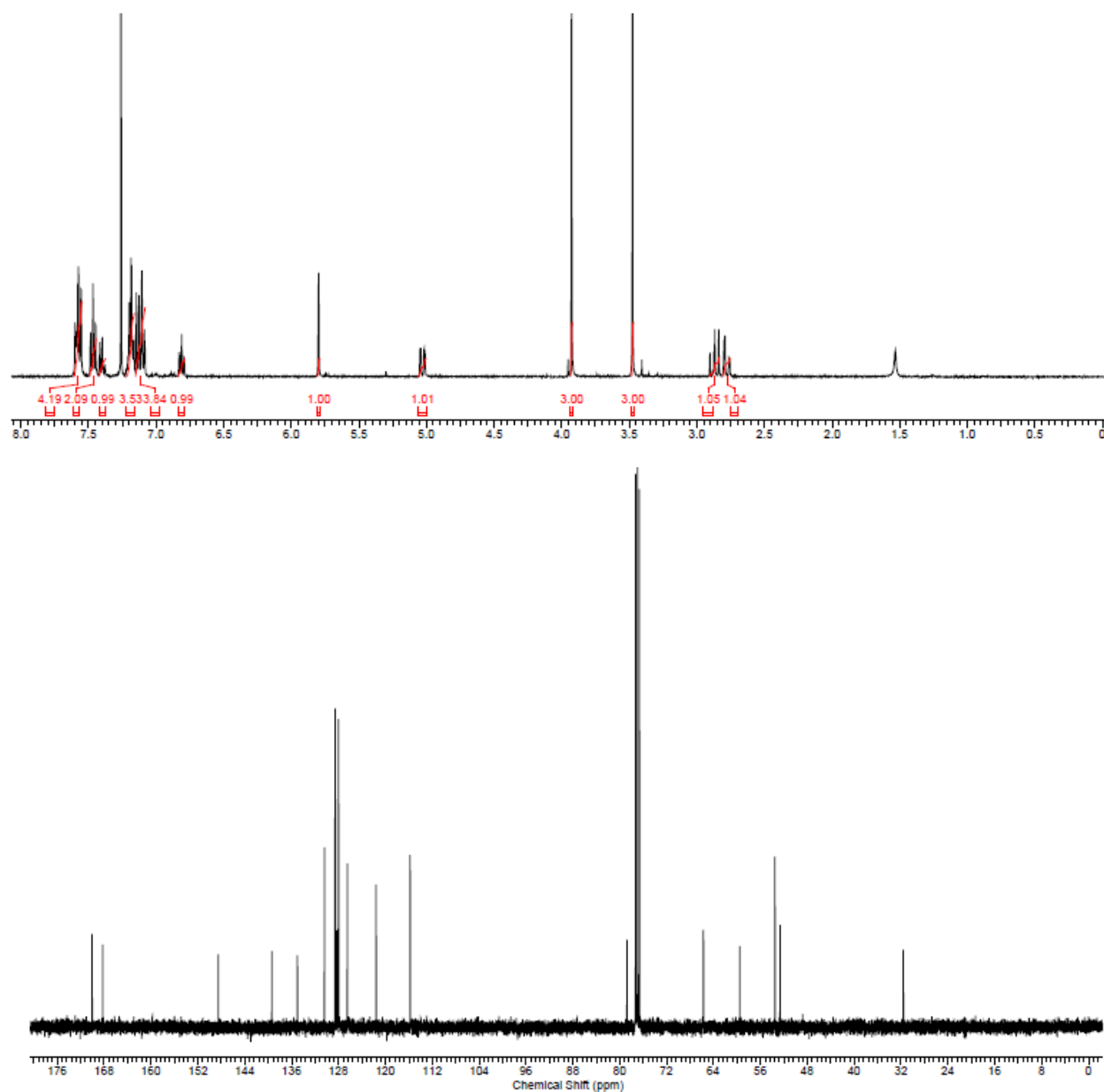
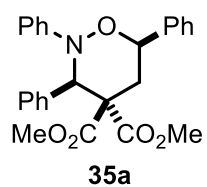

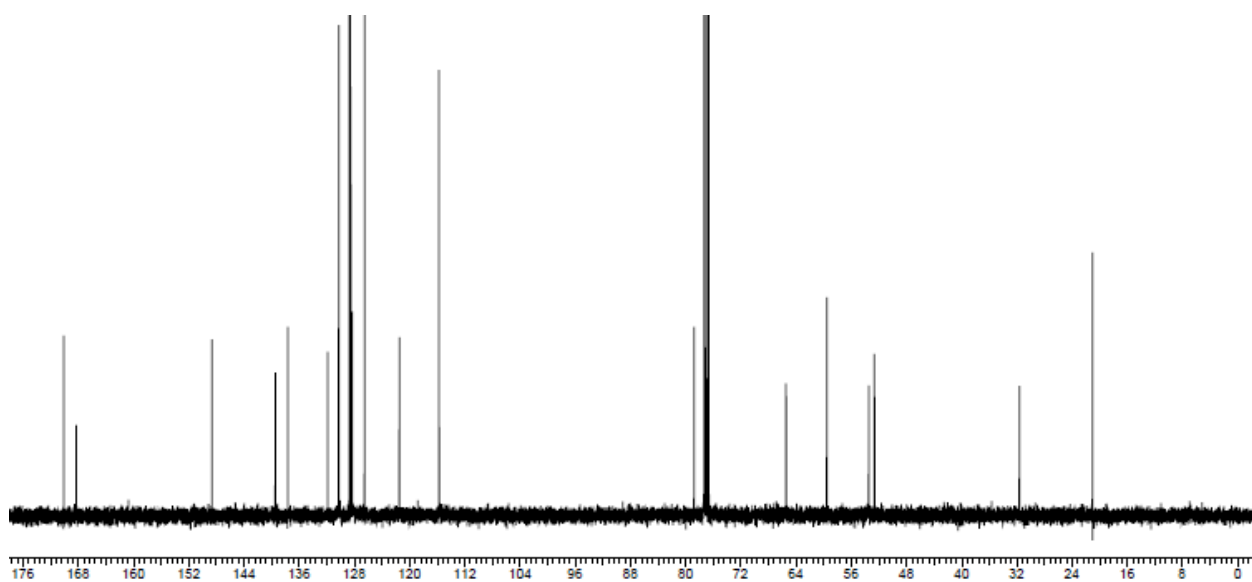
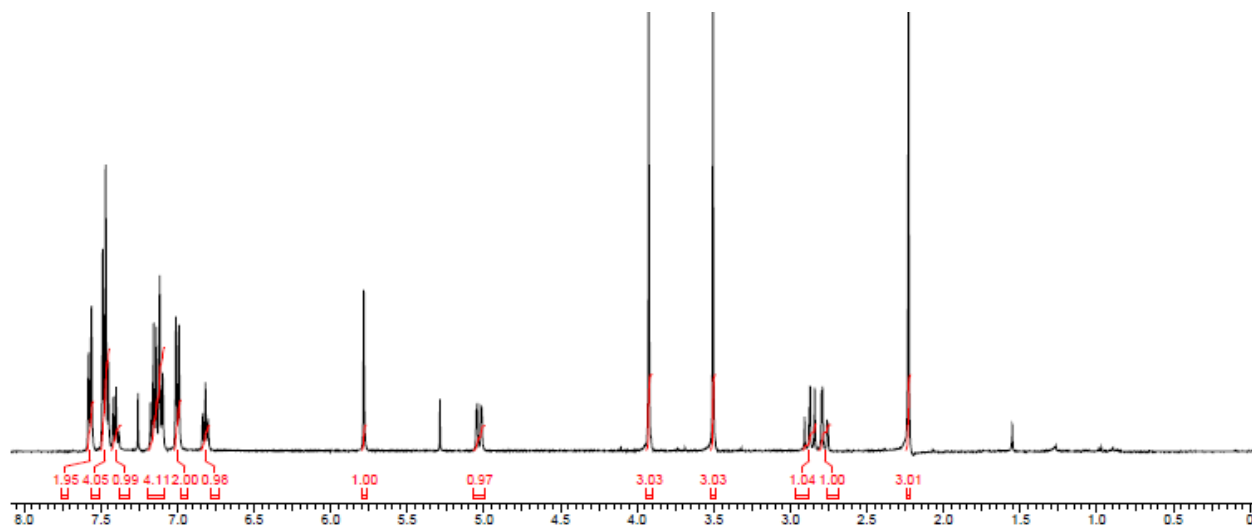
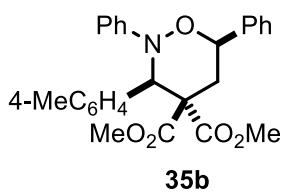

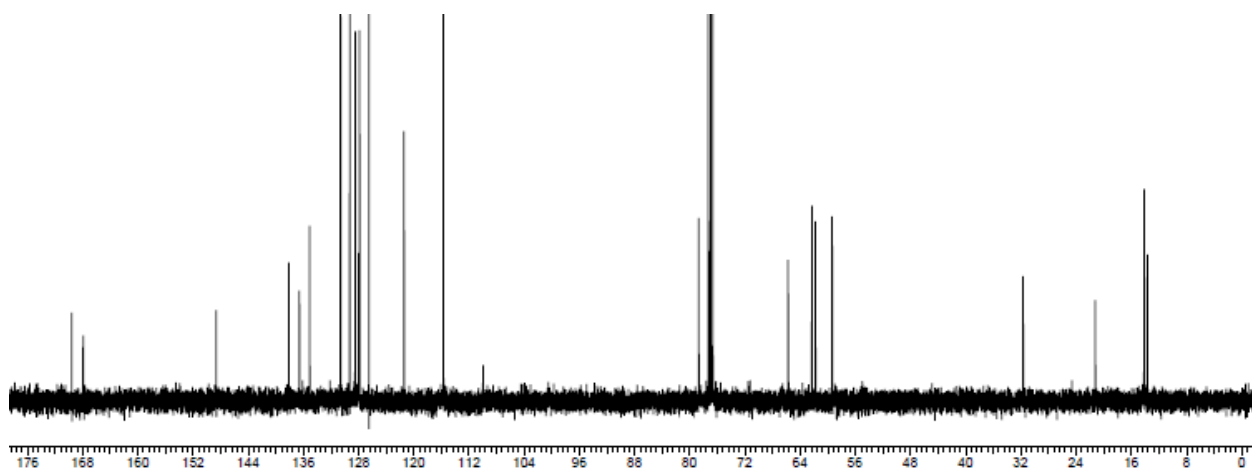
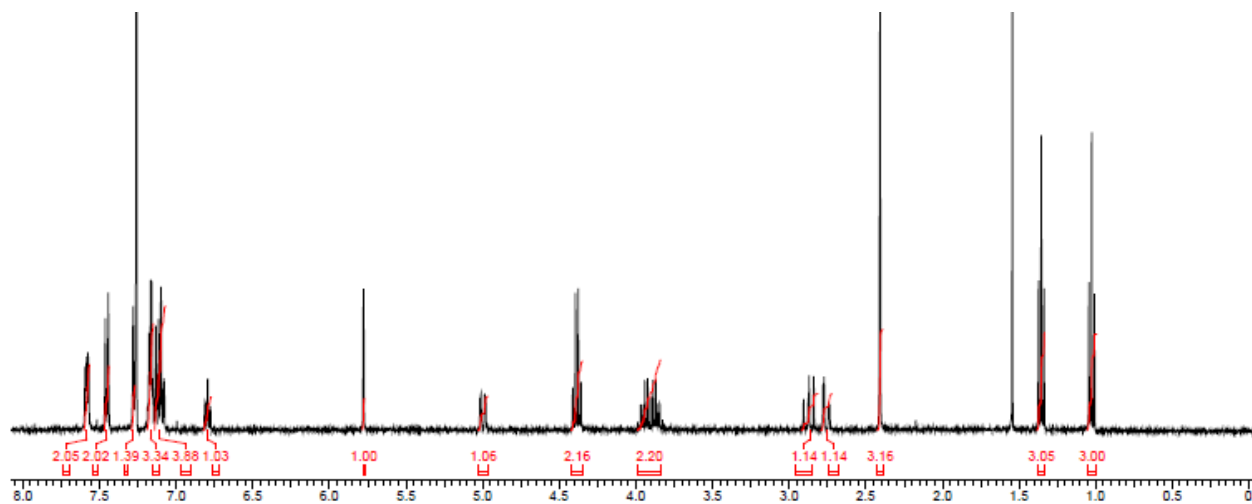
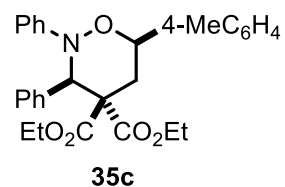

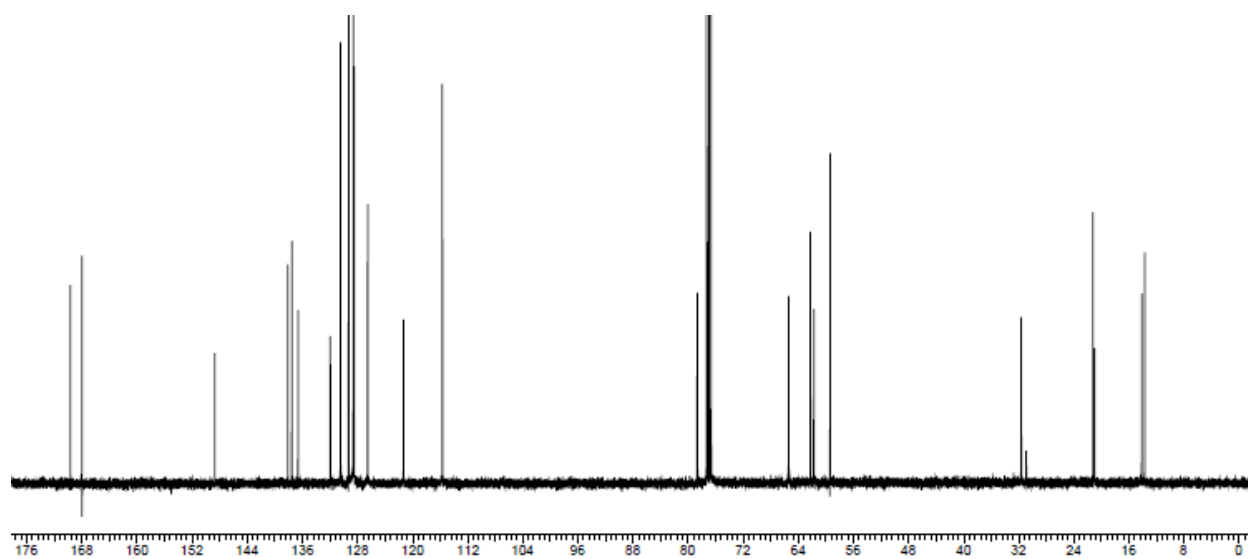
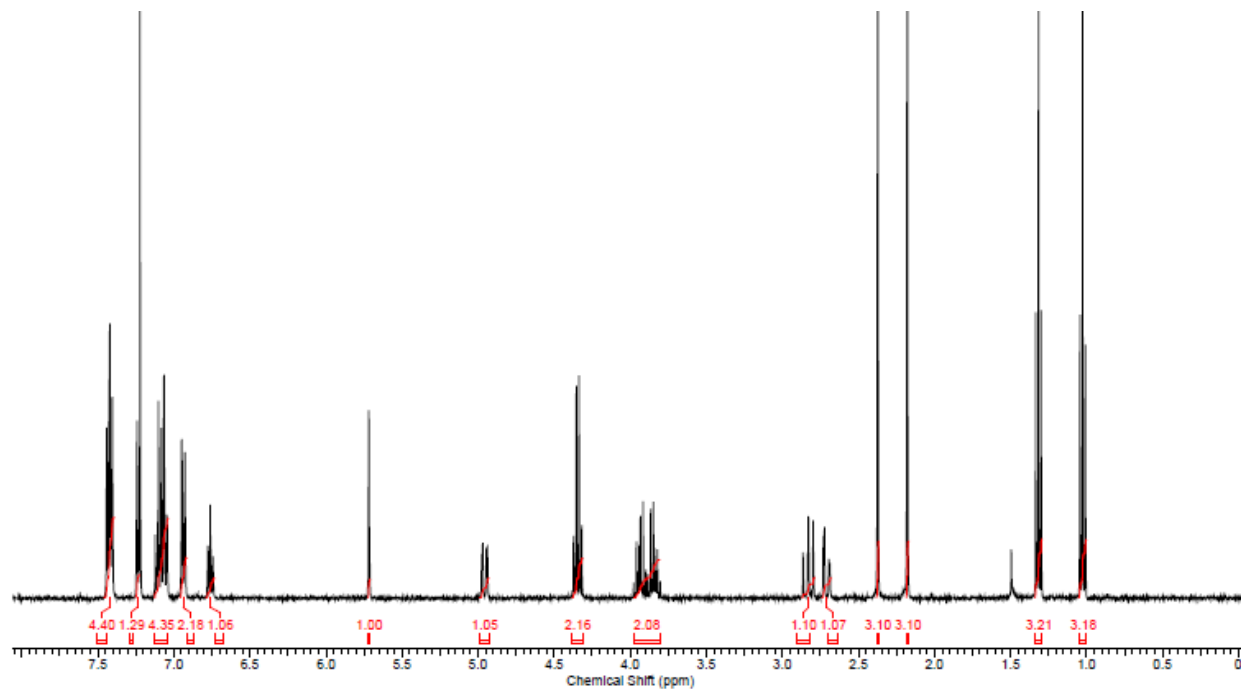
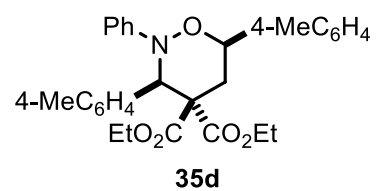

Cross-Over Experiment #1

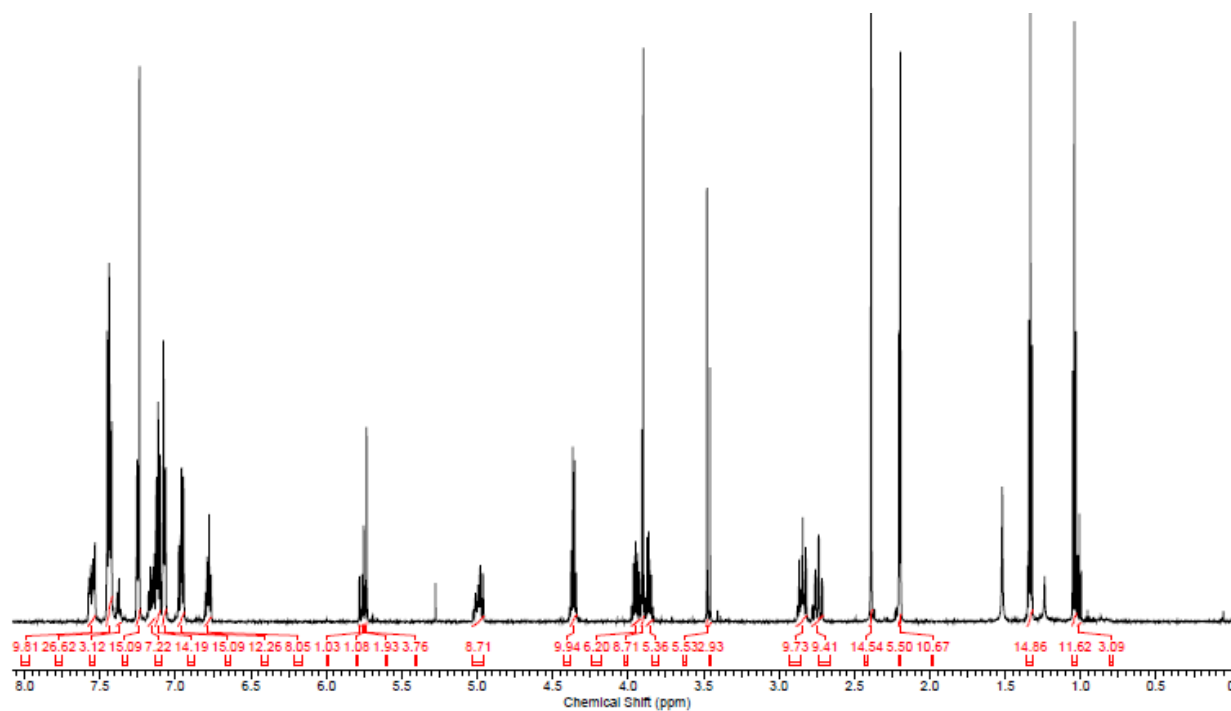

Zoomed into key identifying region

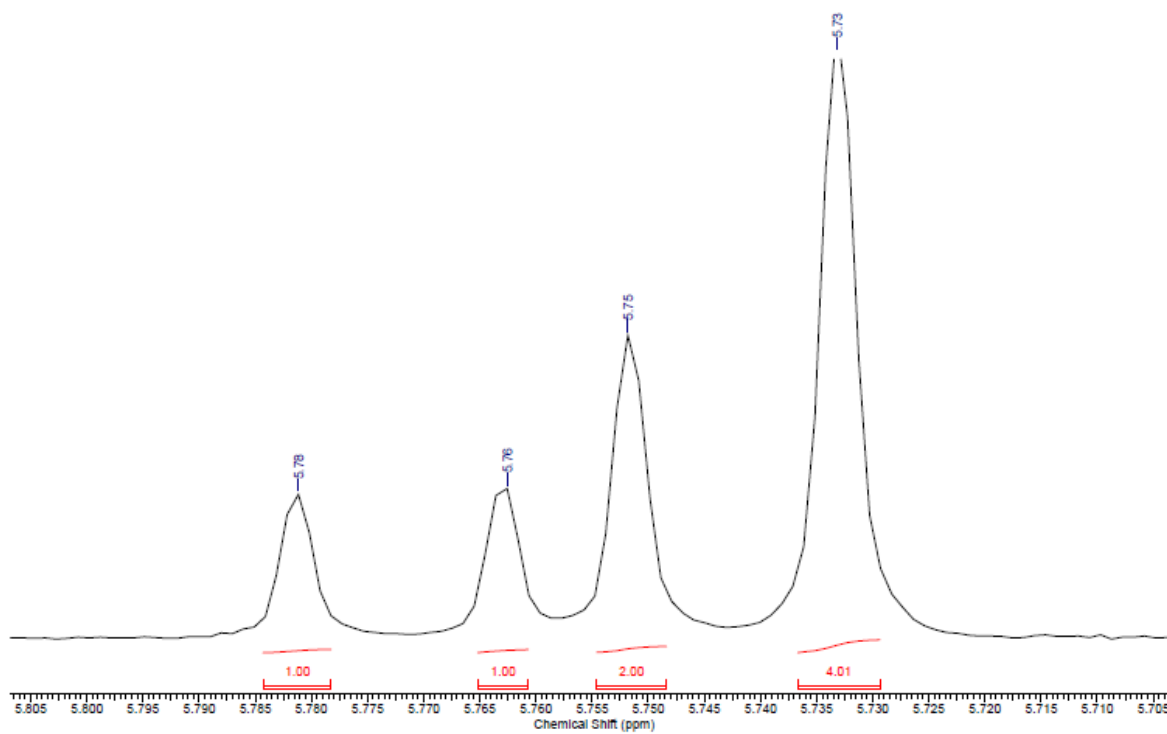

35a

35c

35b

35d

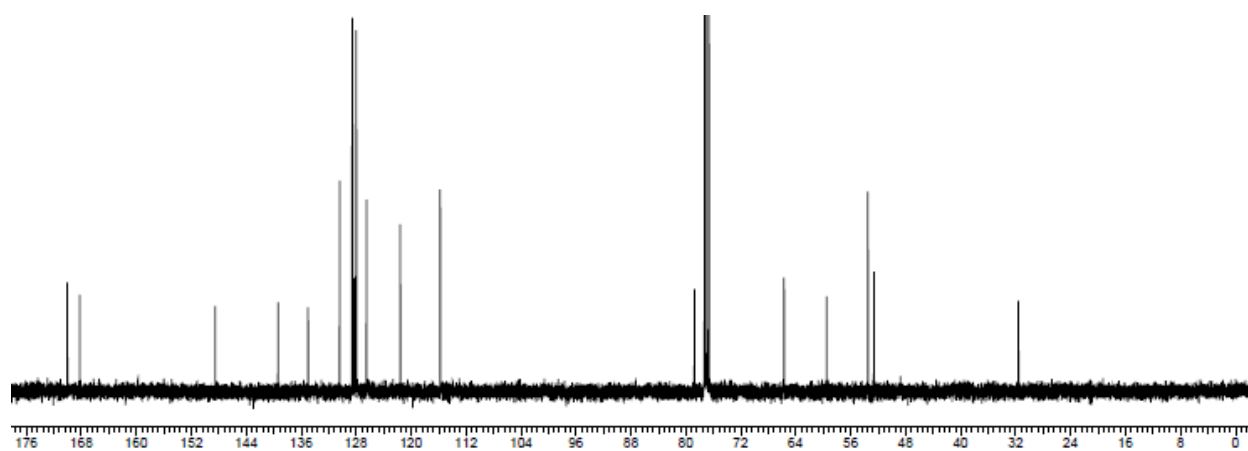
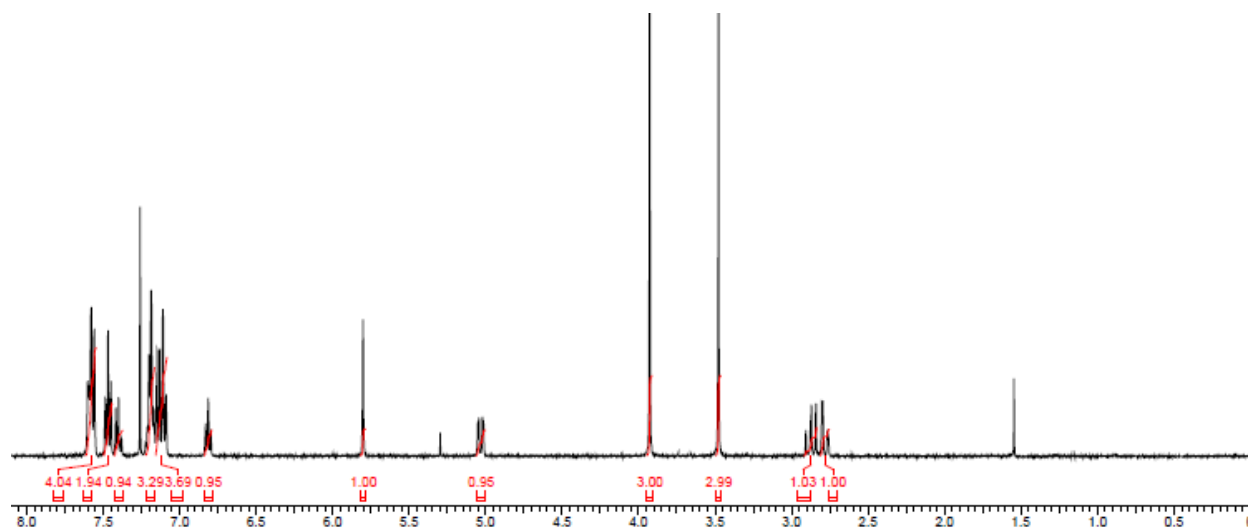
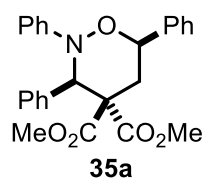

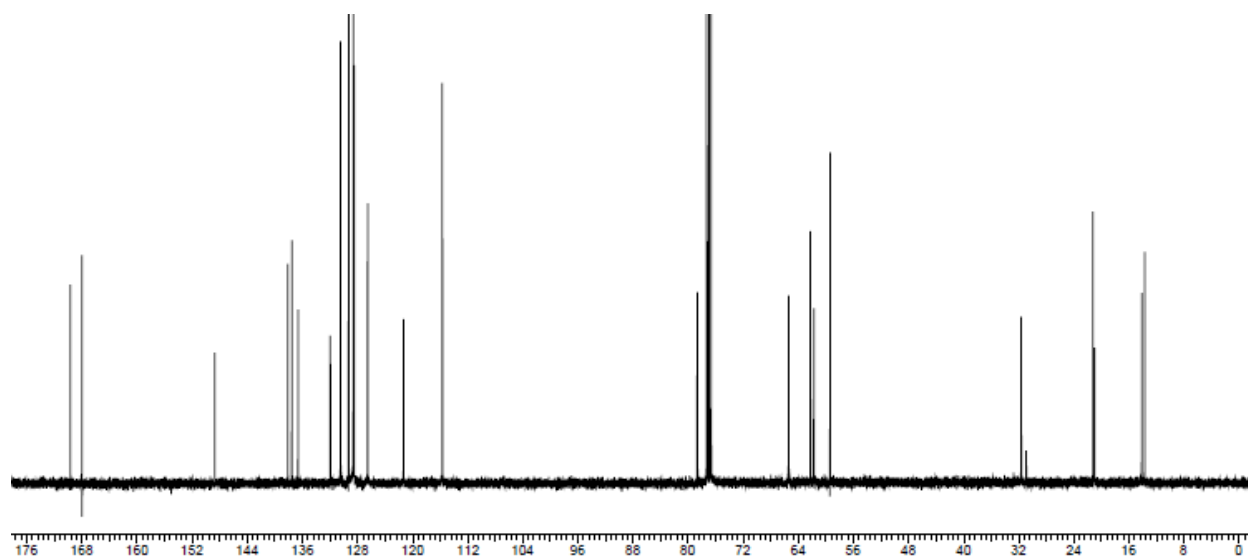
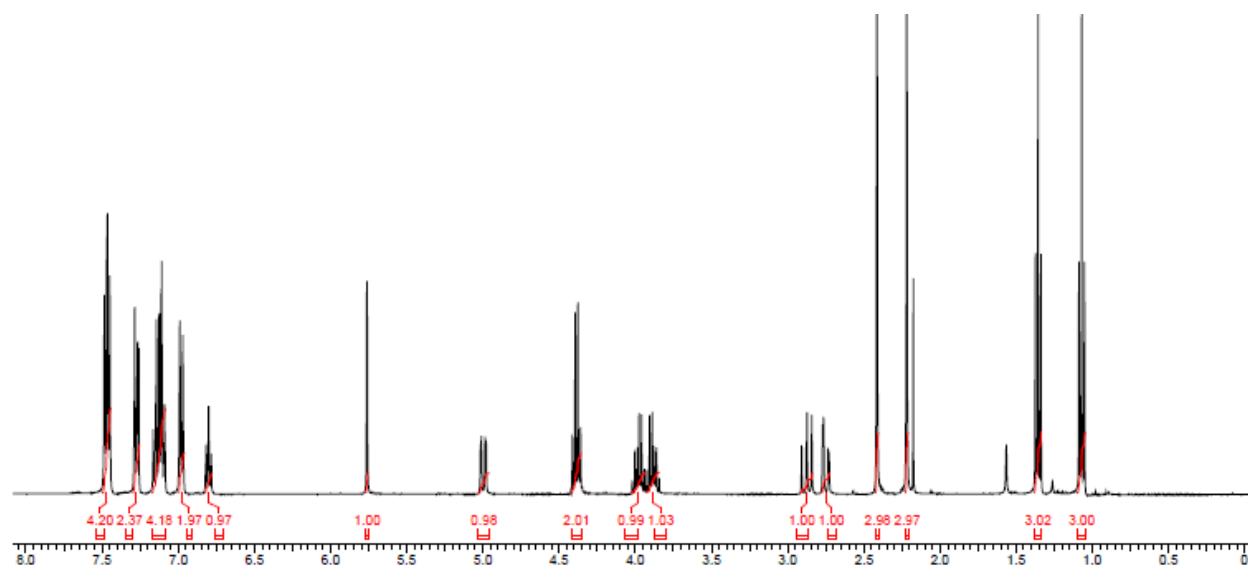
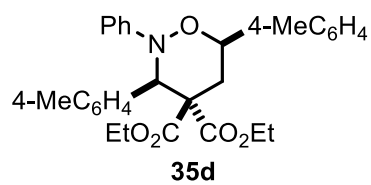

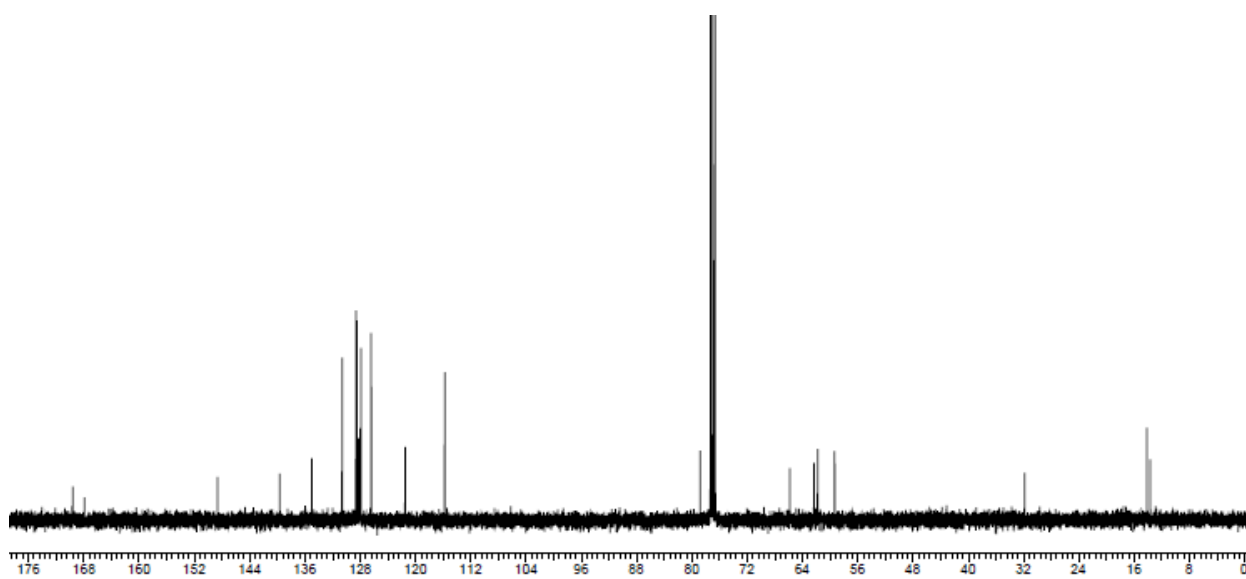
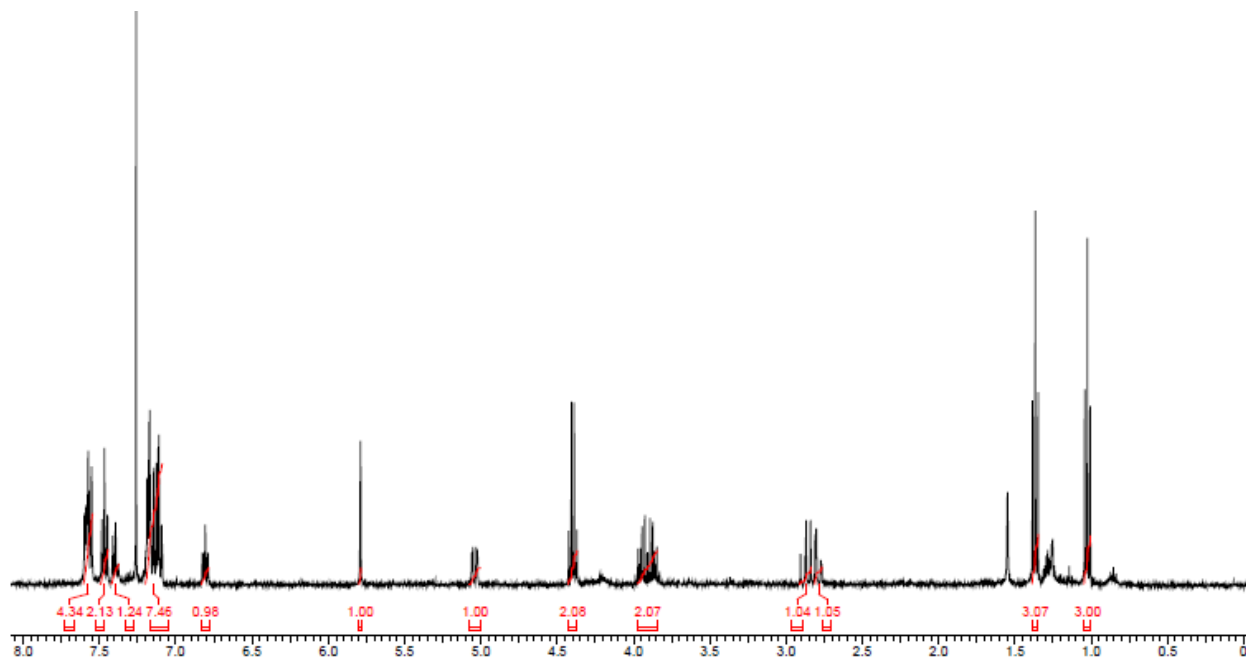
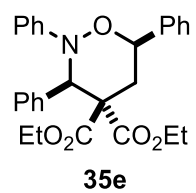

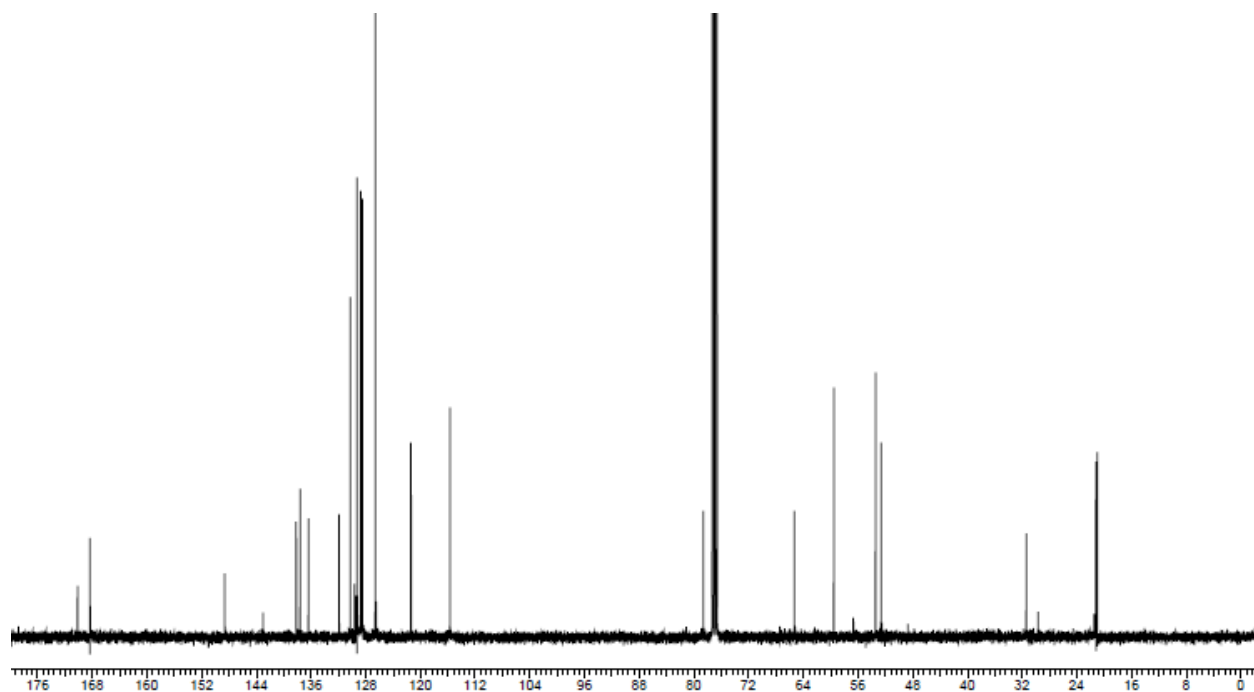
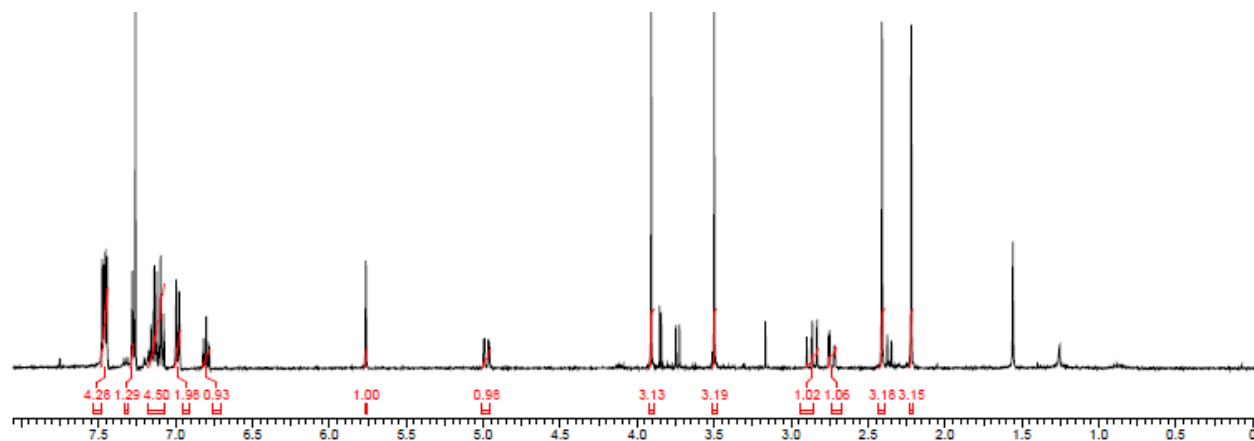
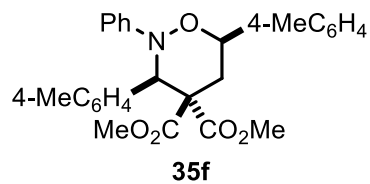

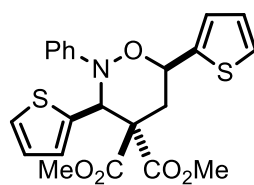

35g

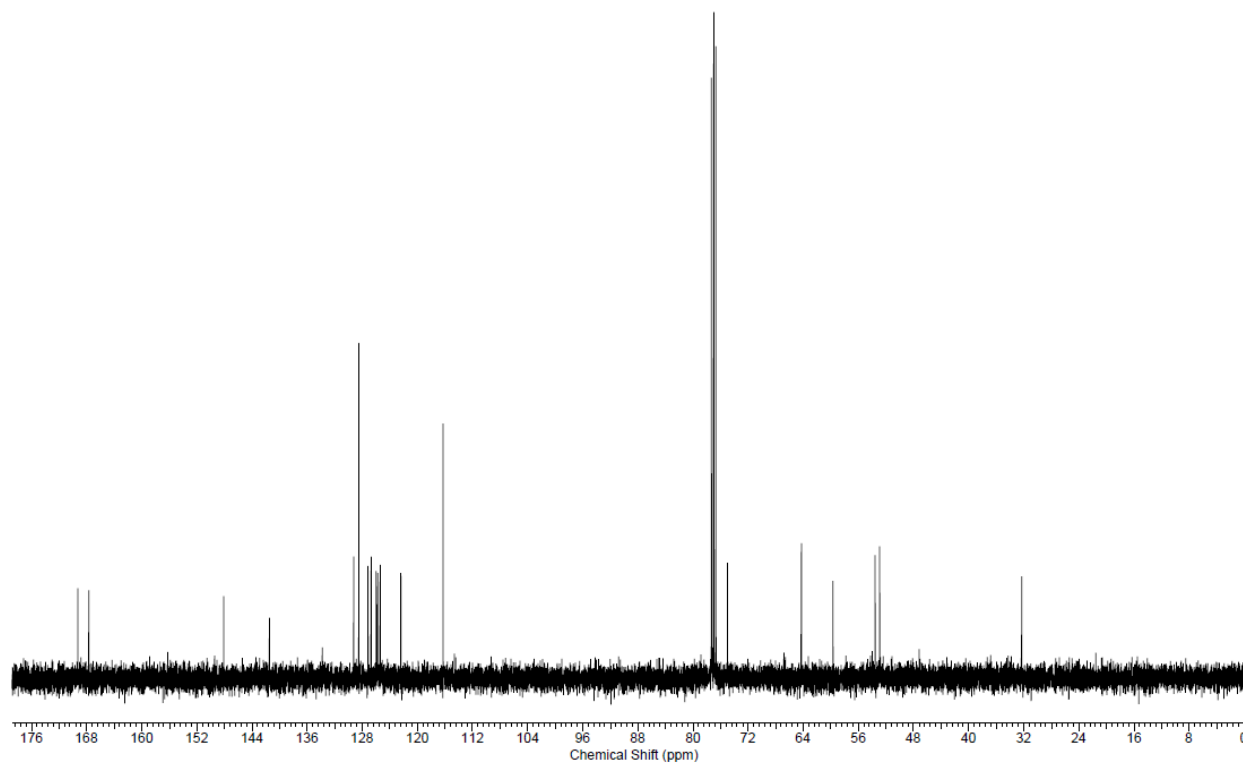
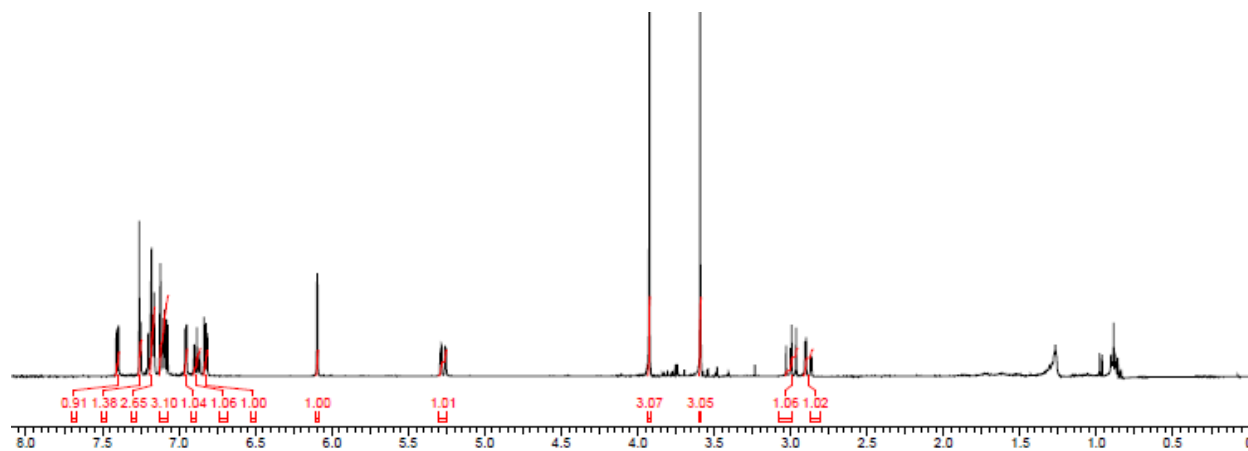

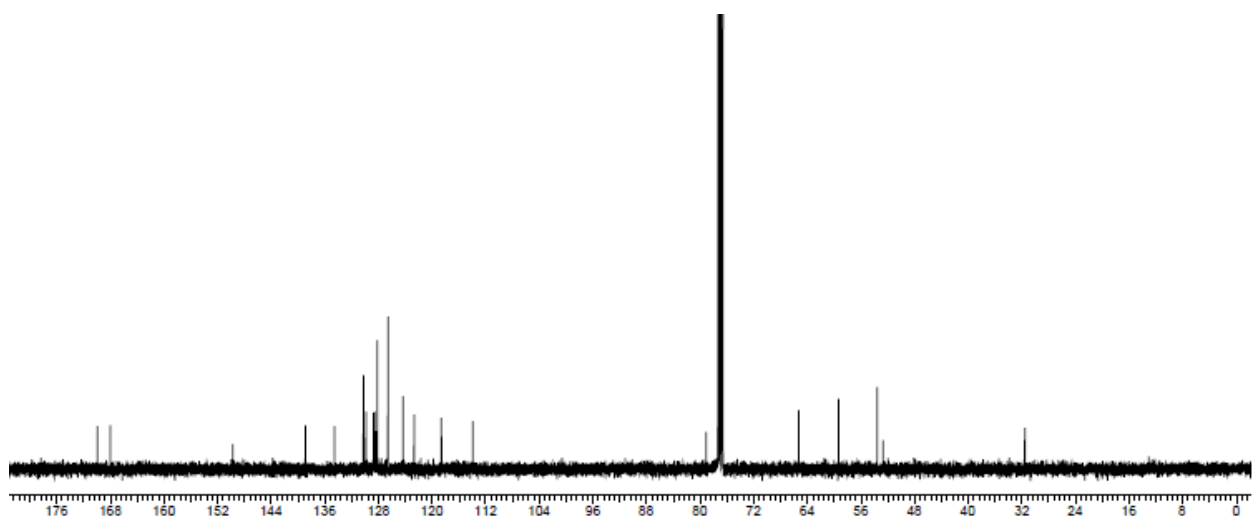
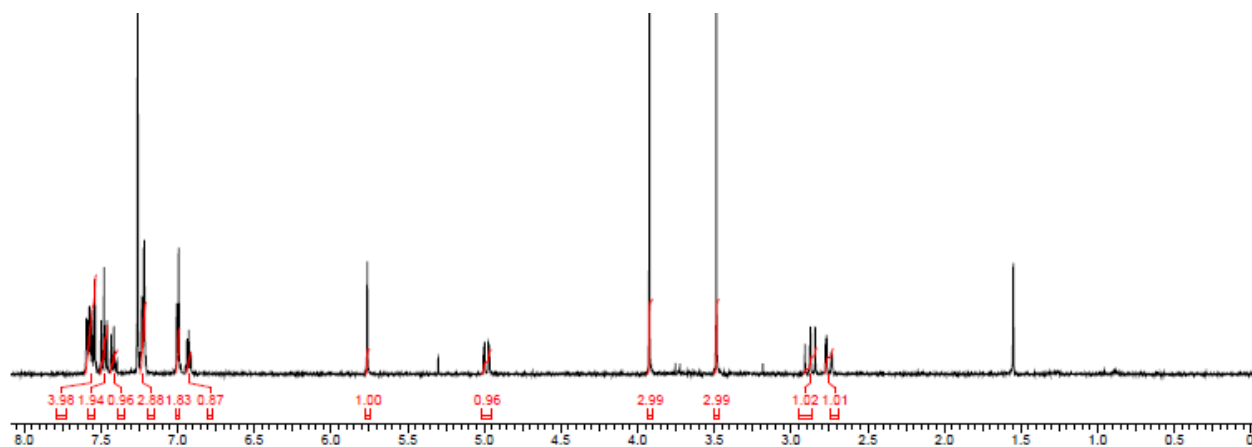
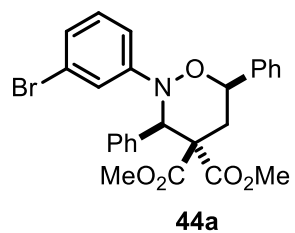

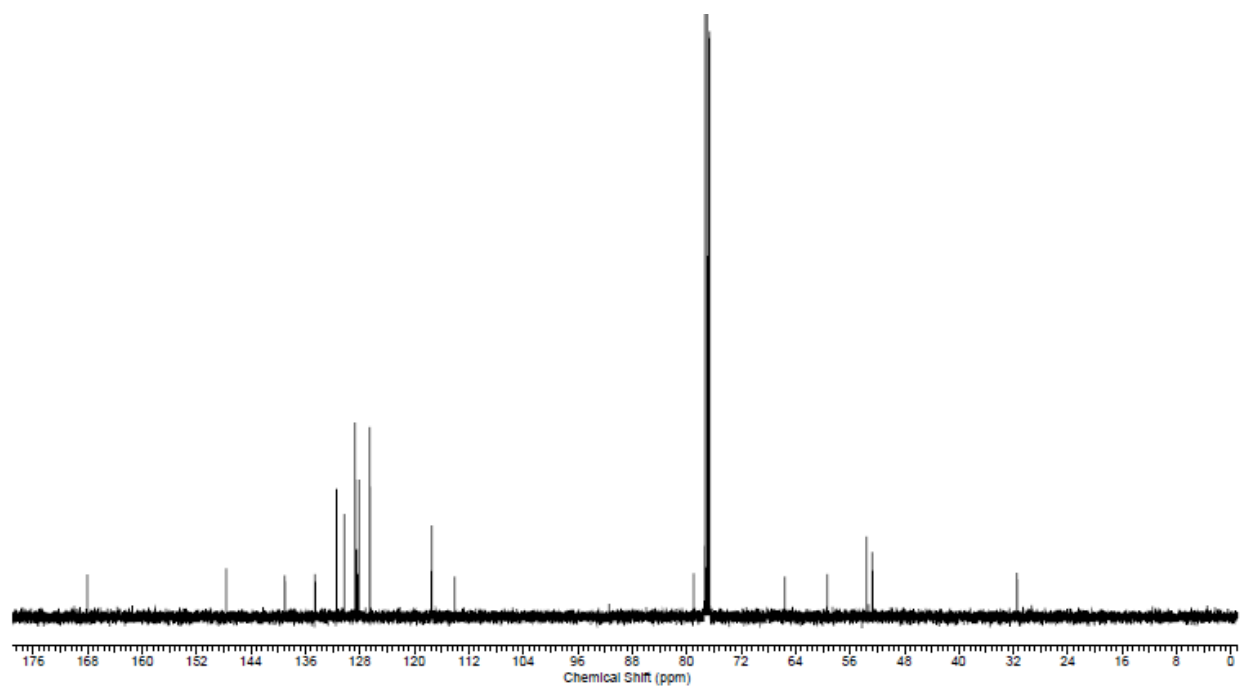
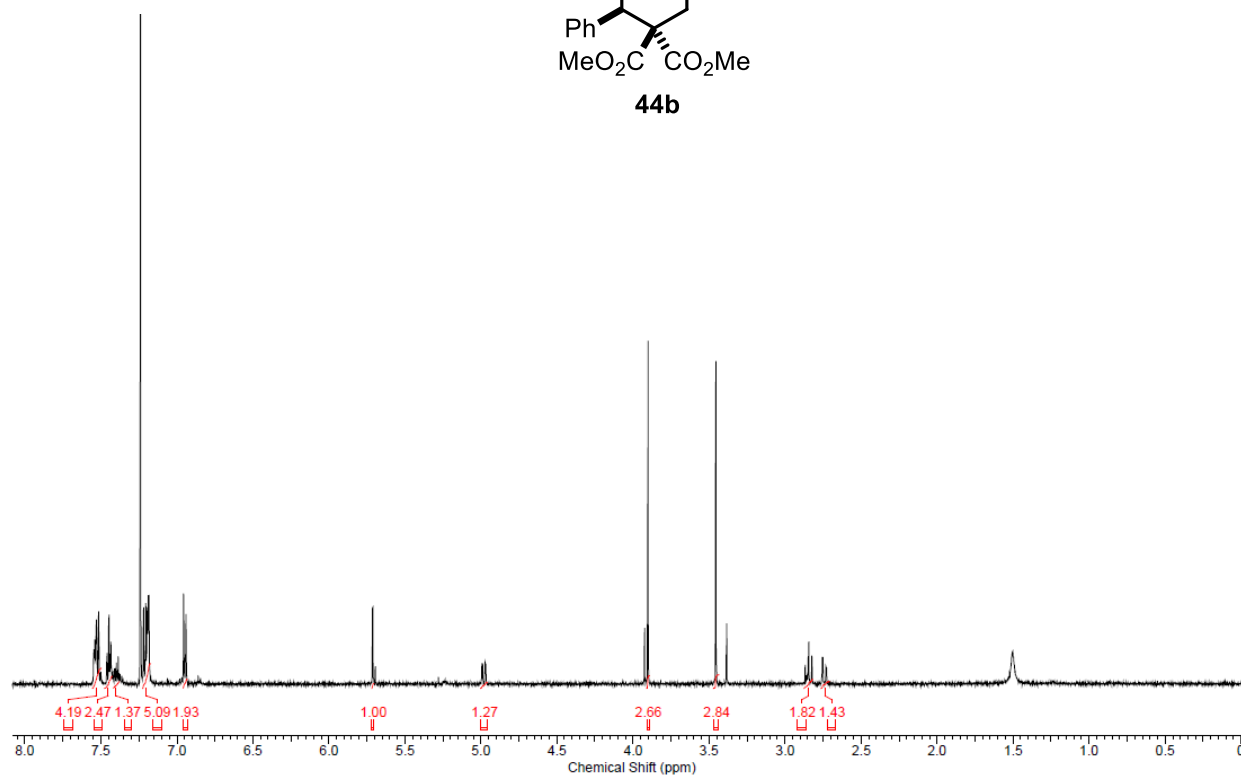
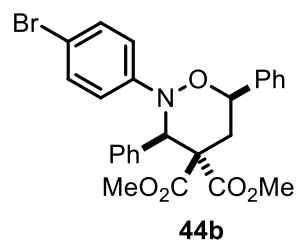

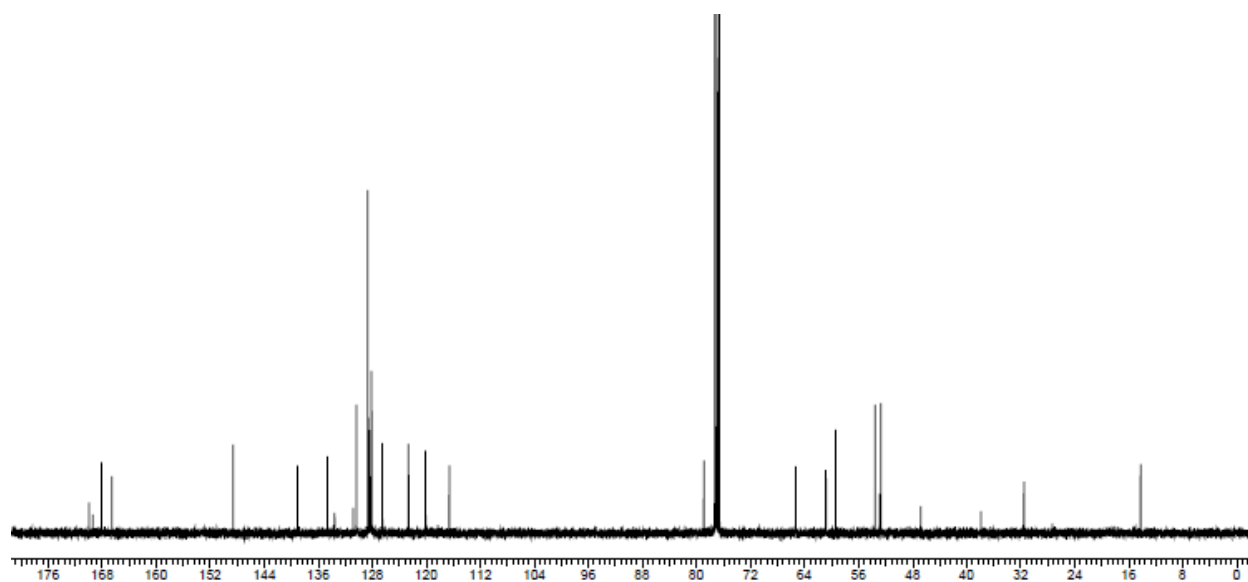
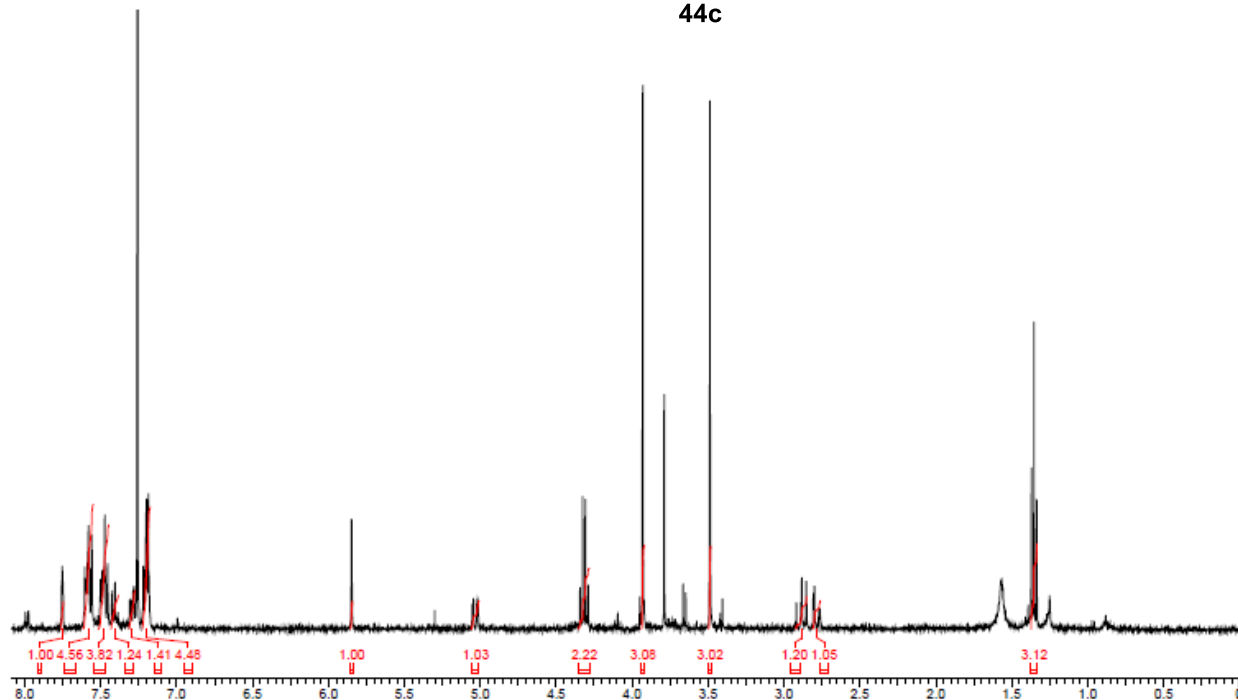
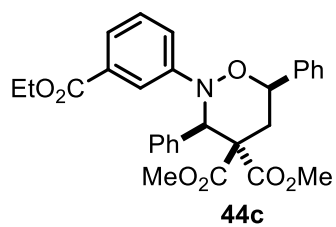

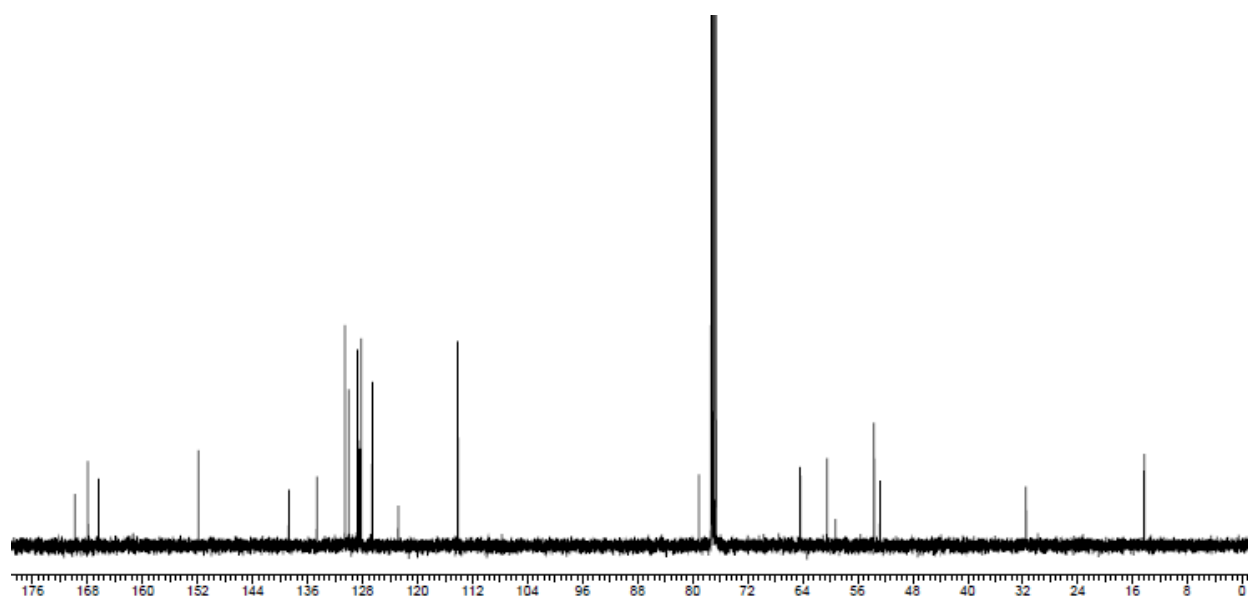
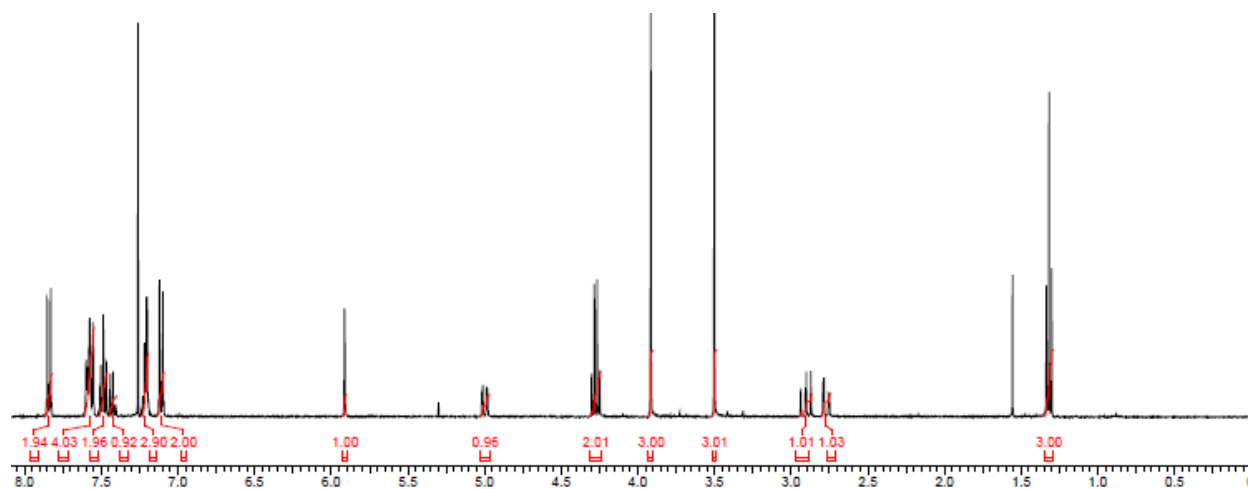
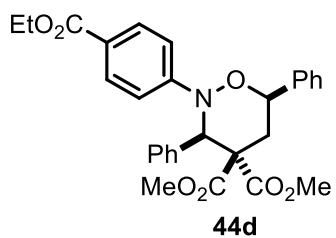

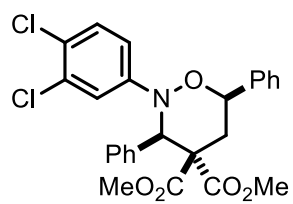

44e

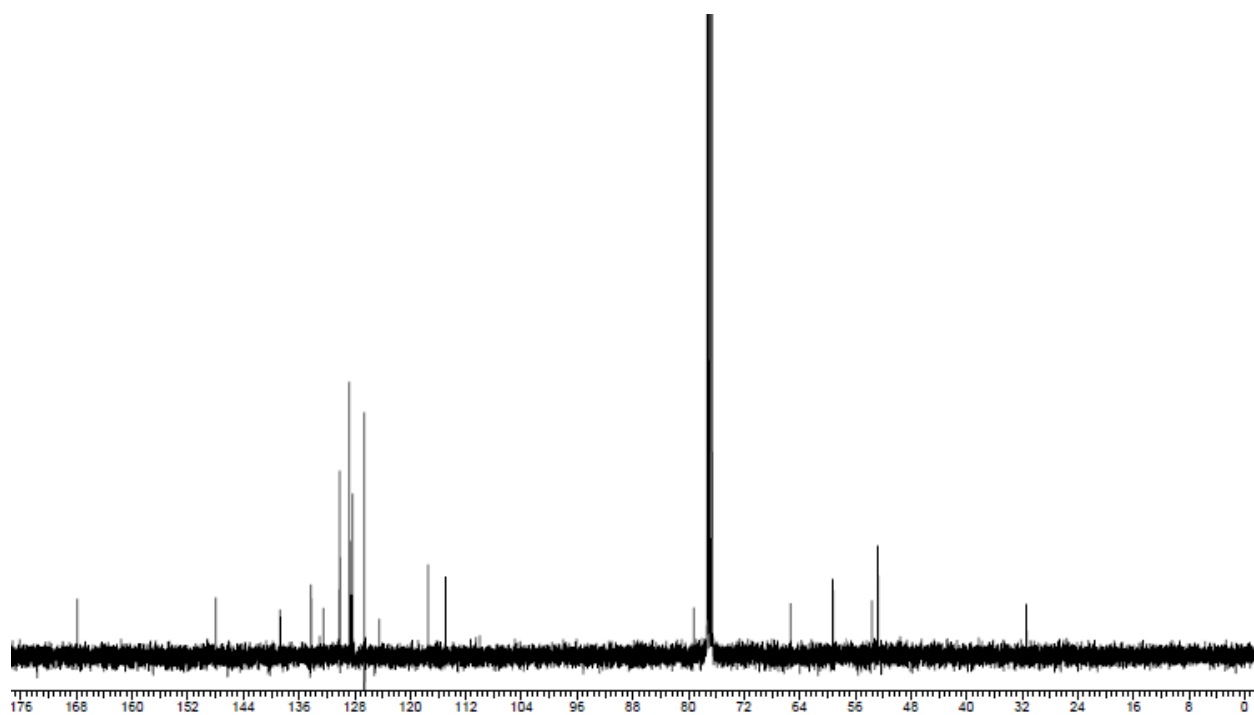
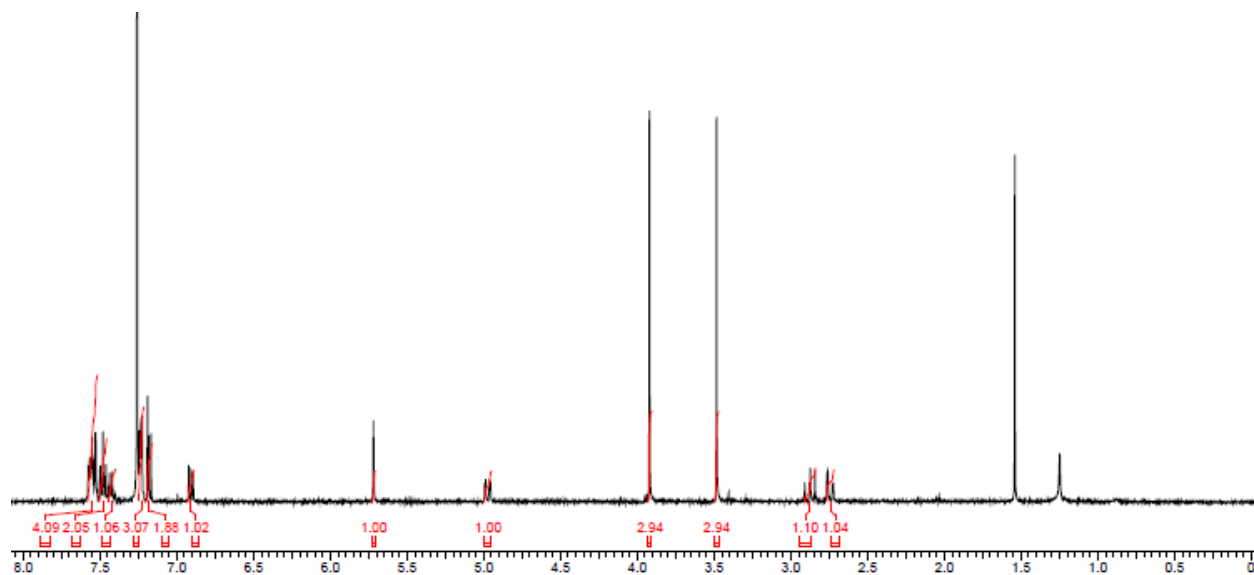

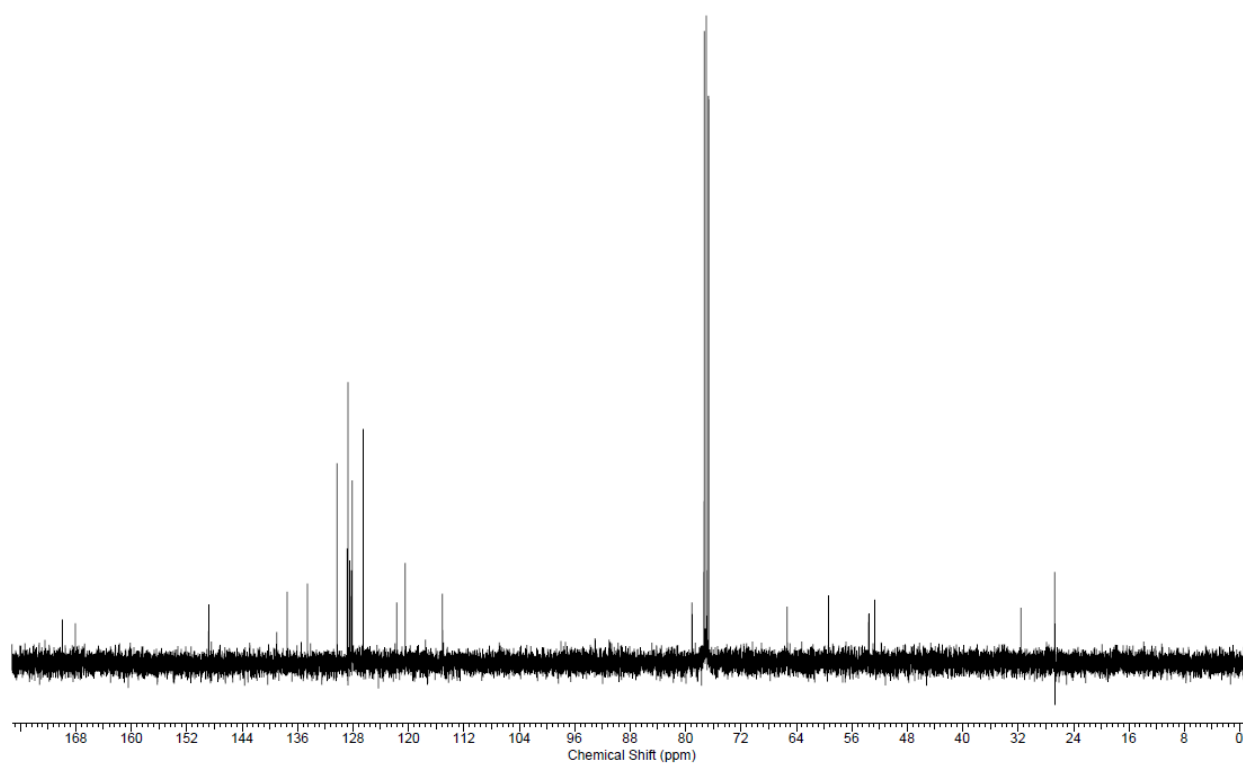
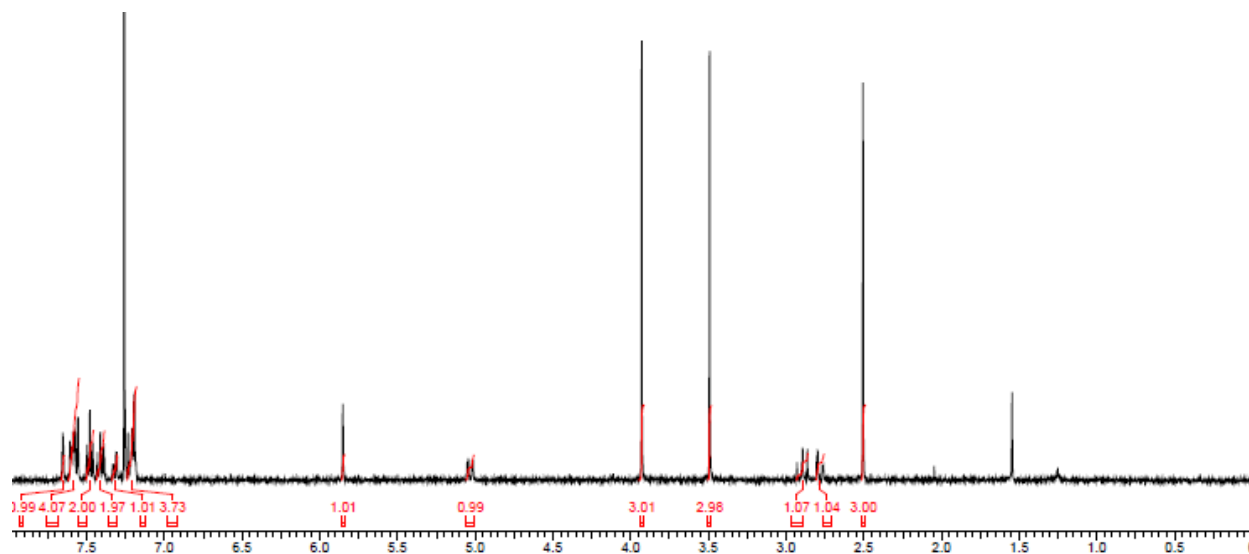
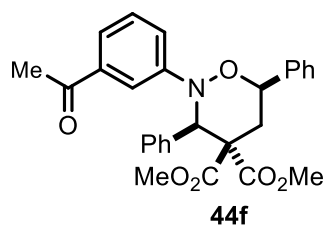

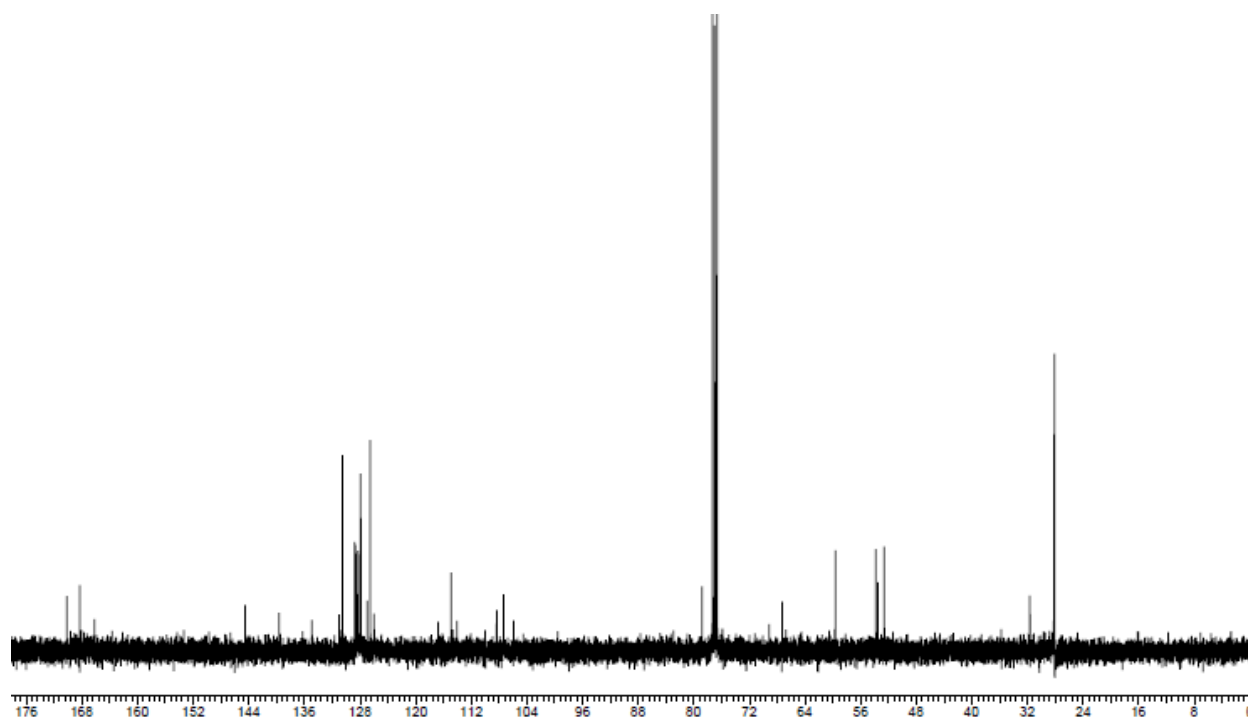
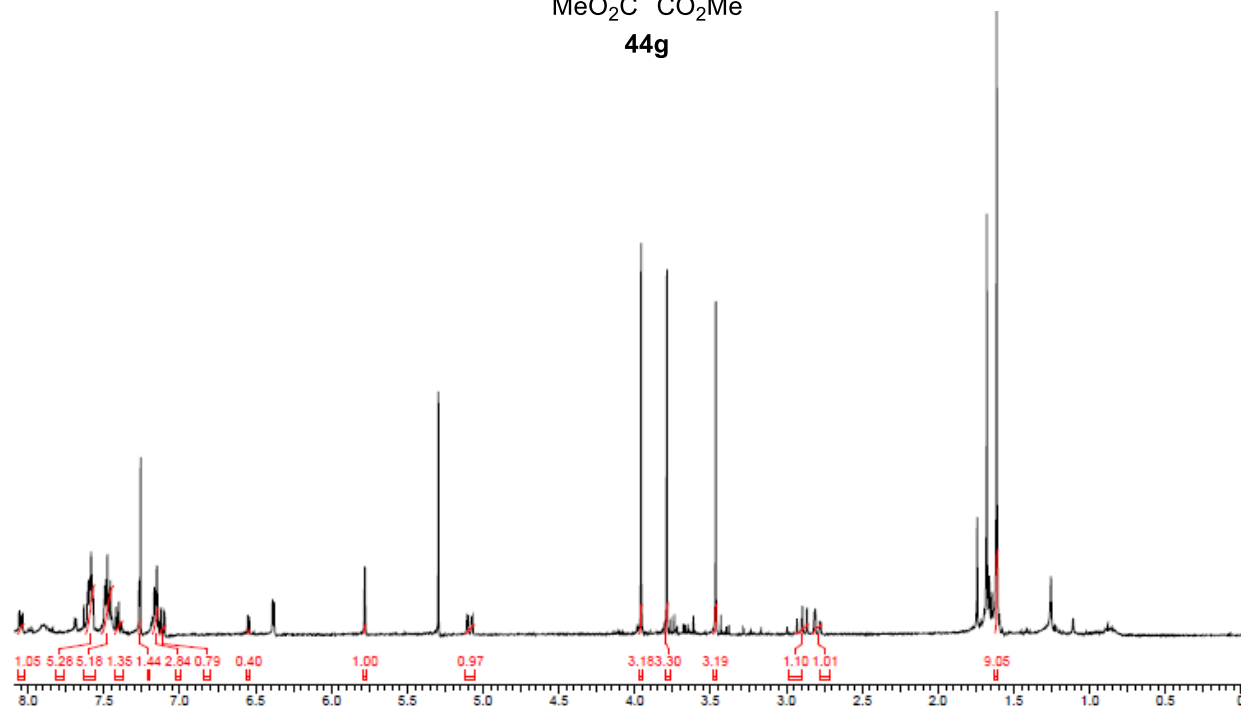
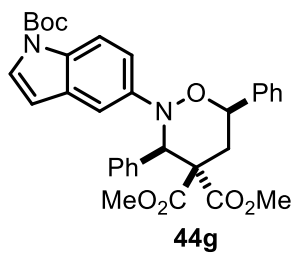

Appendix 2 - NMR Data Chapter 3

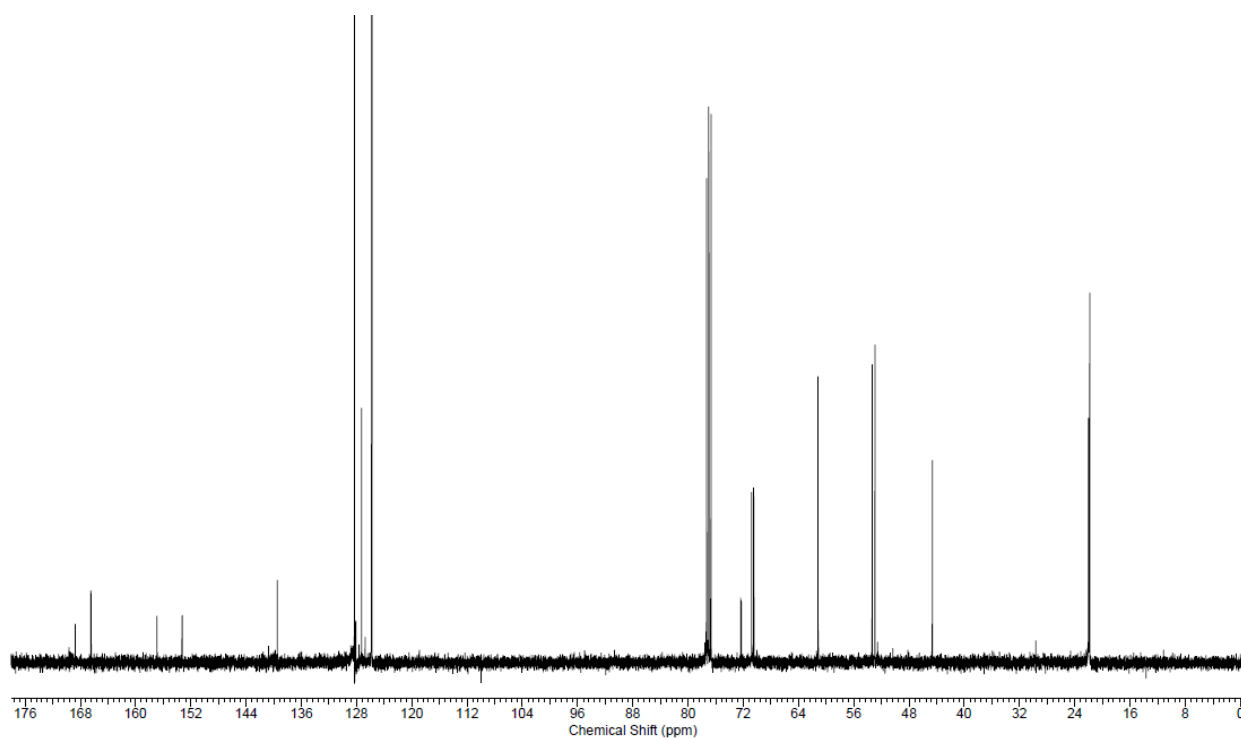
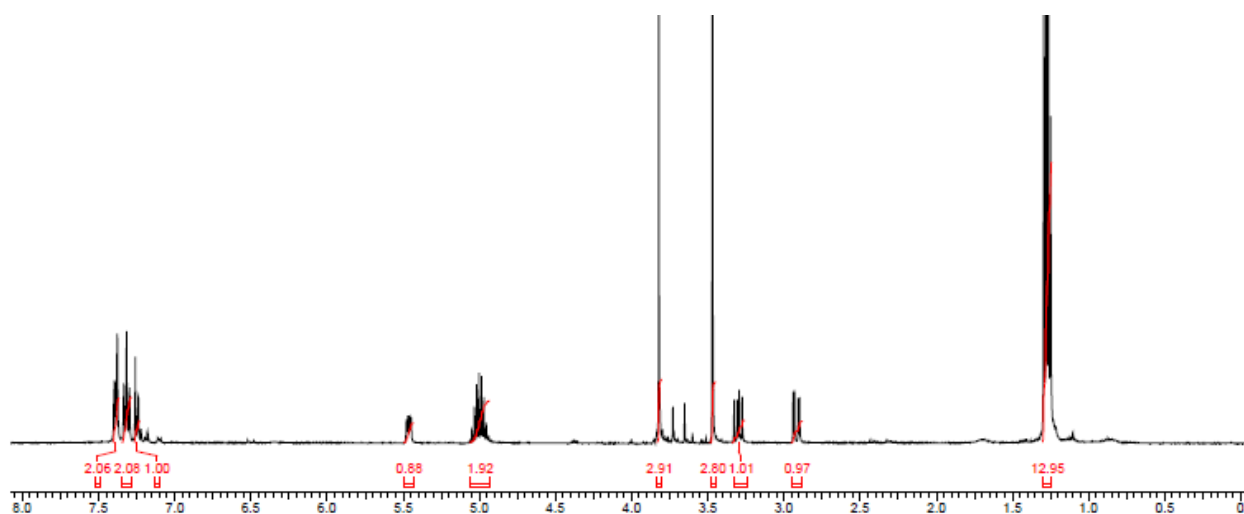
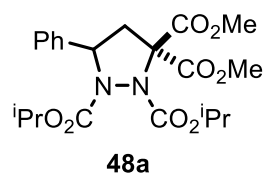

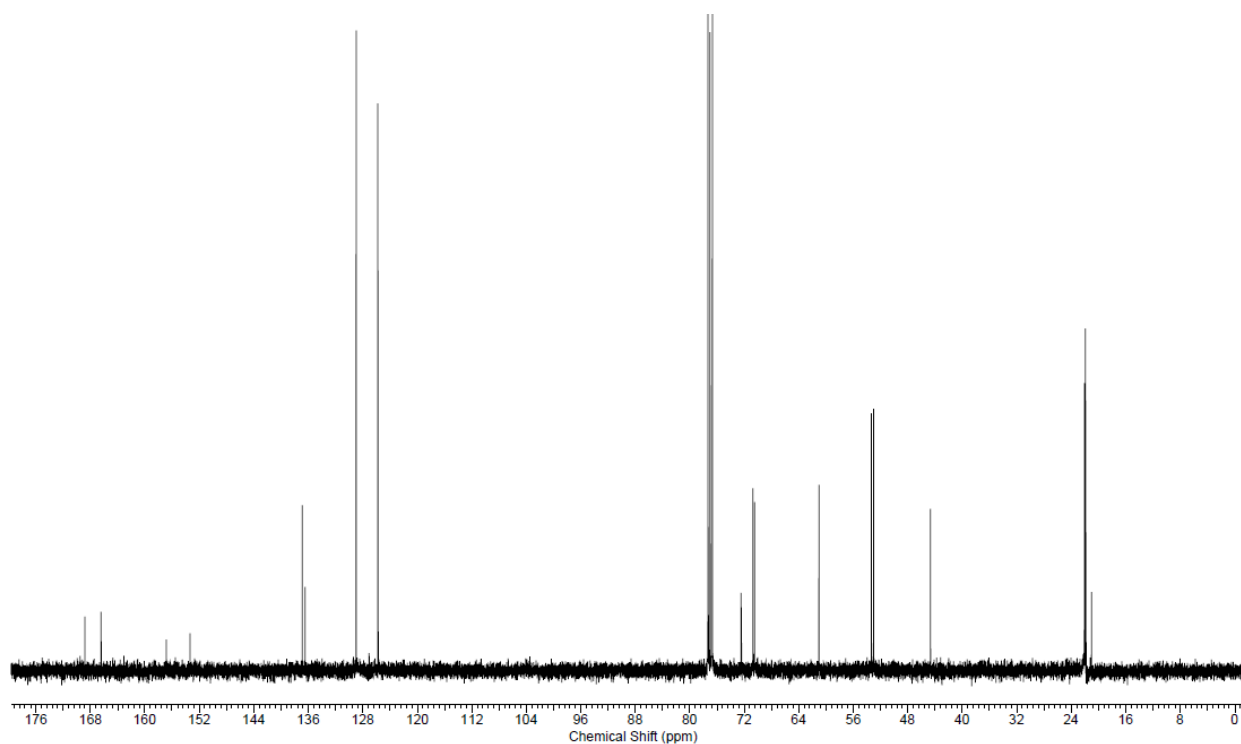
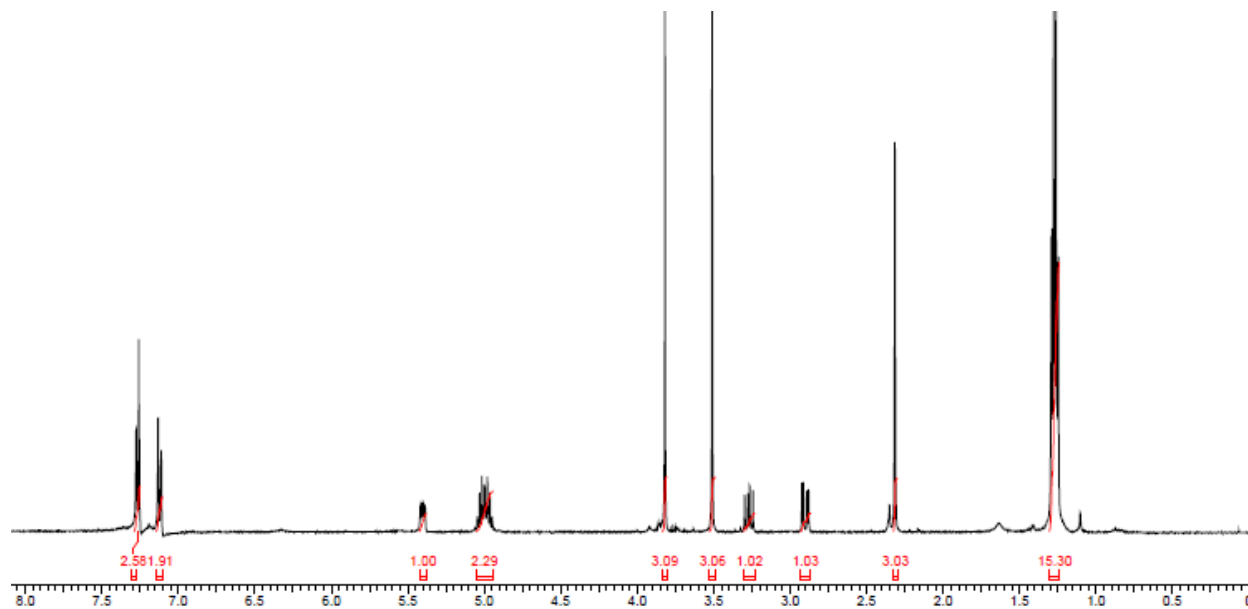
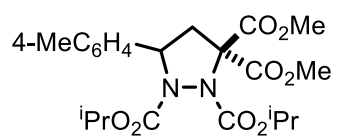

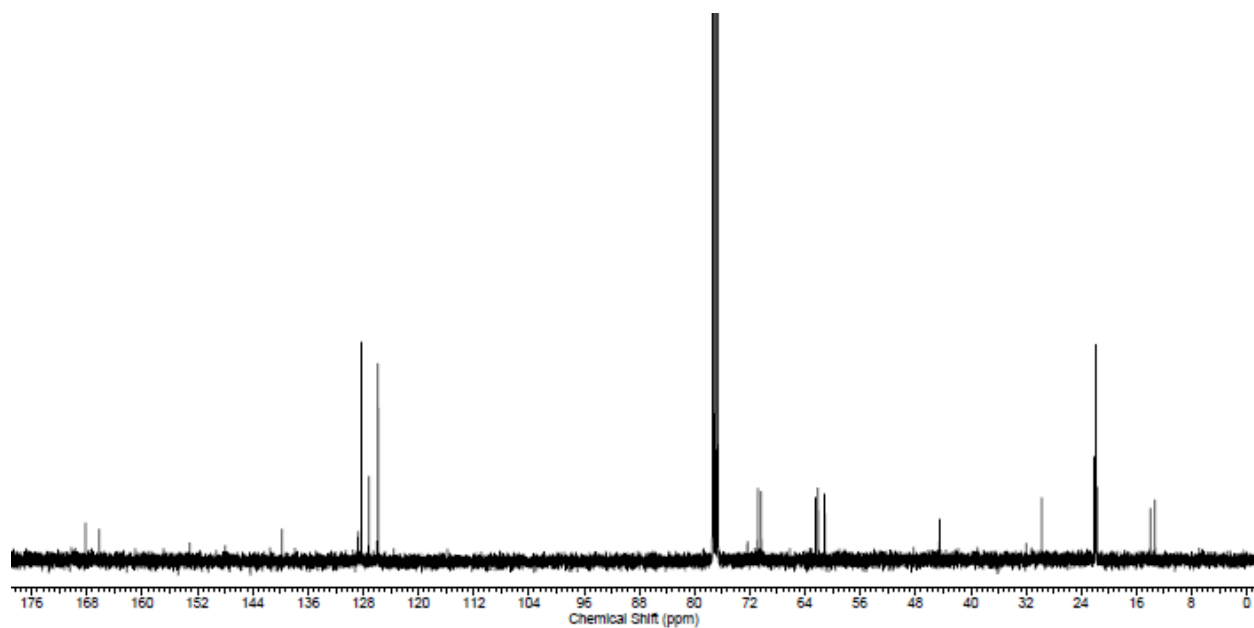
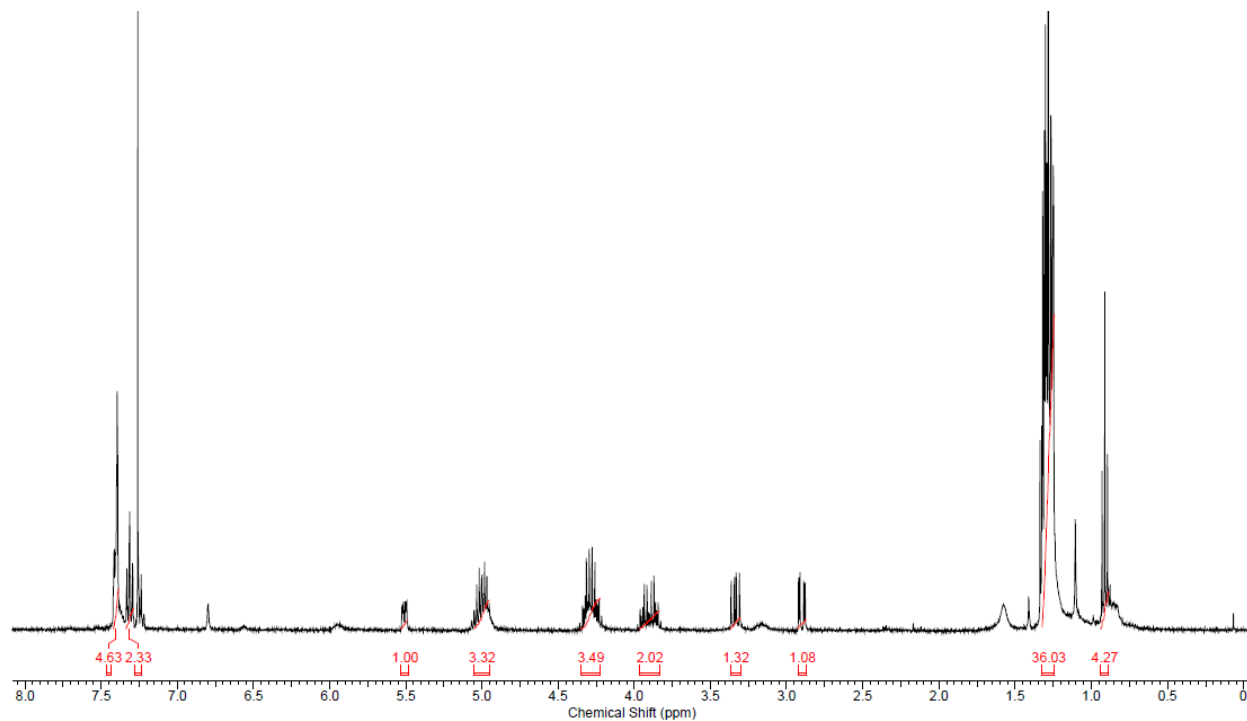
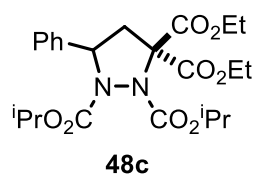

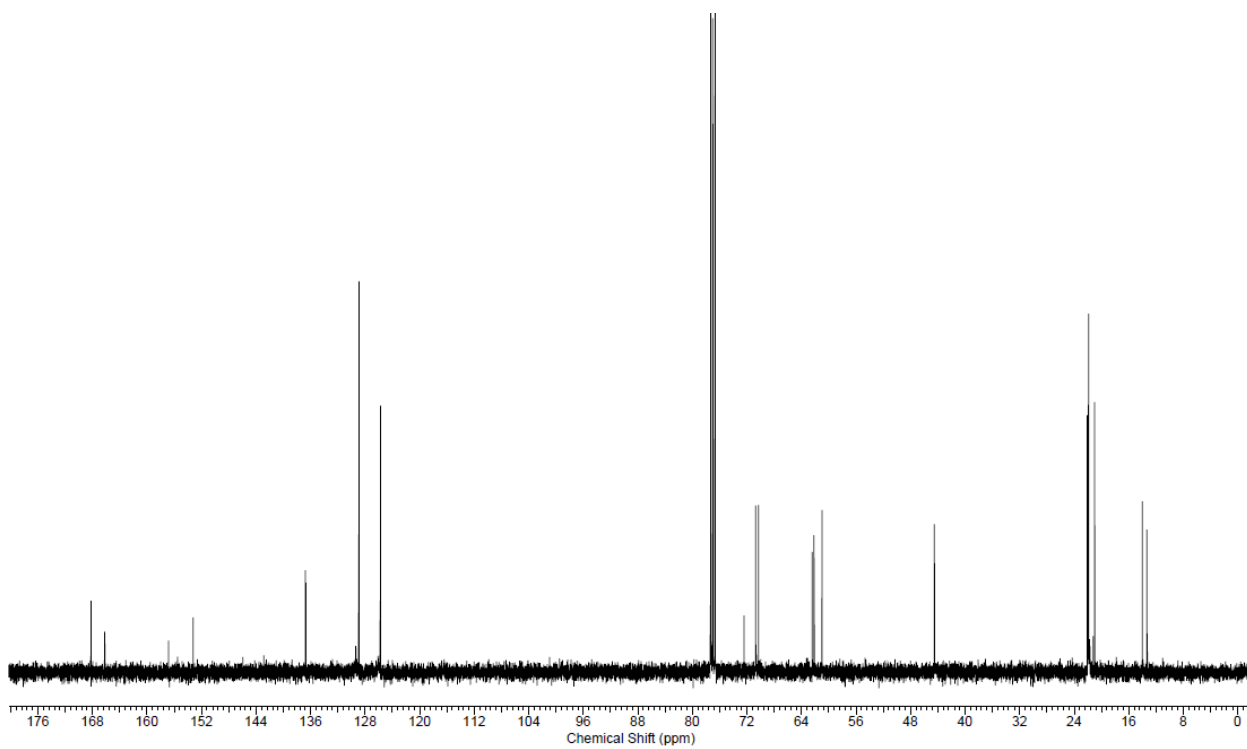
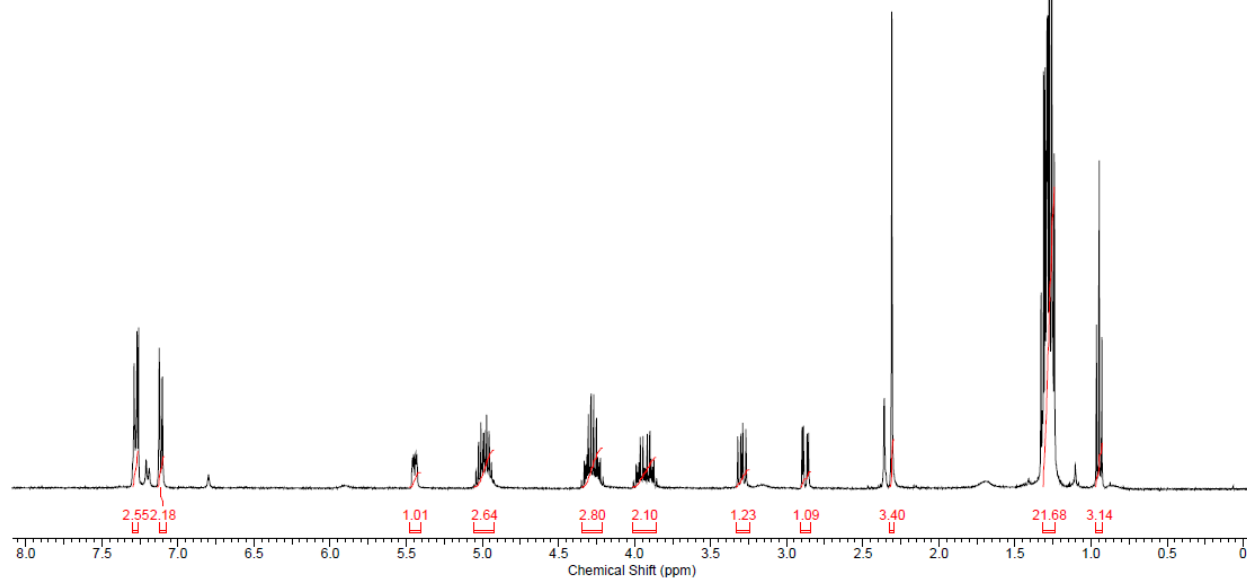
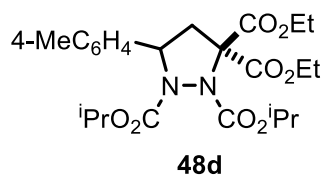

Cross-Over Experiment #2

Crude Reaction Mixture

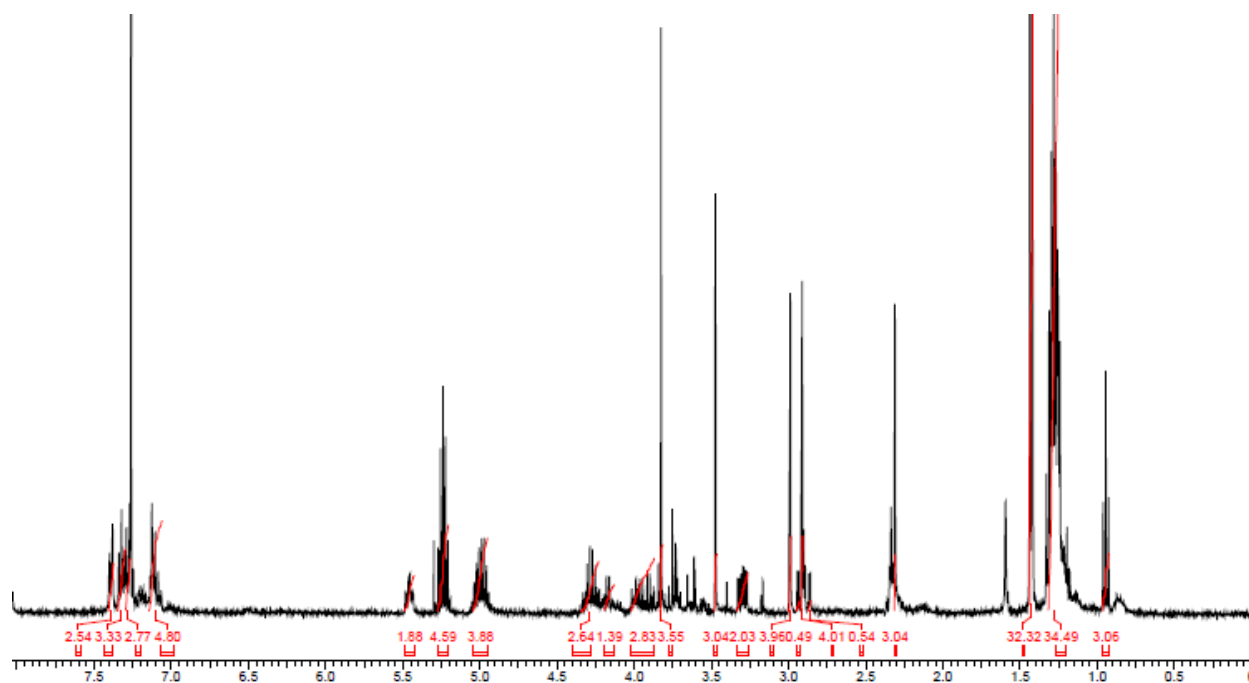

Cross-Over Experiment #2

Isolated Products

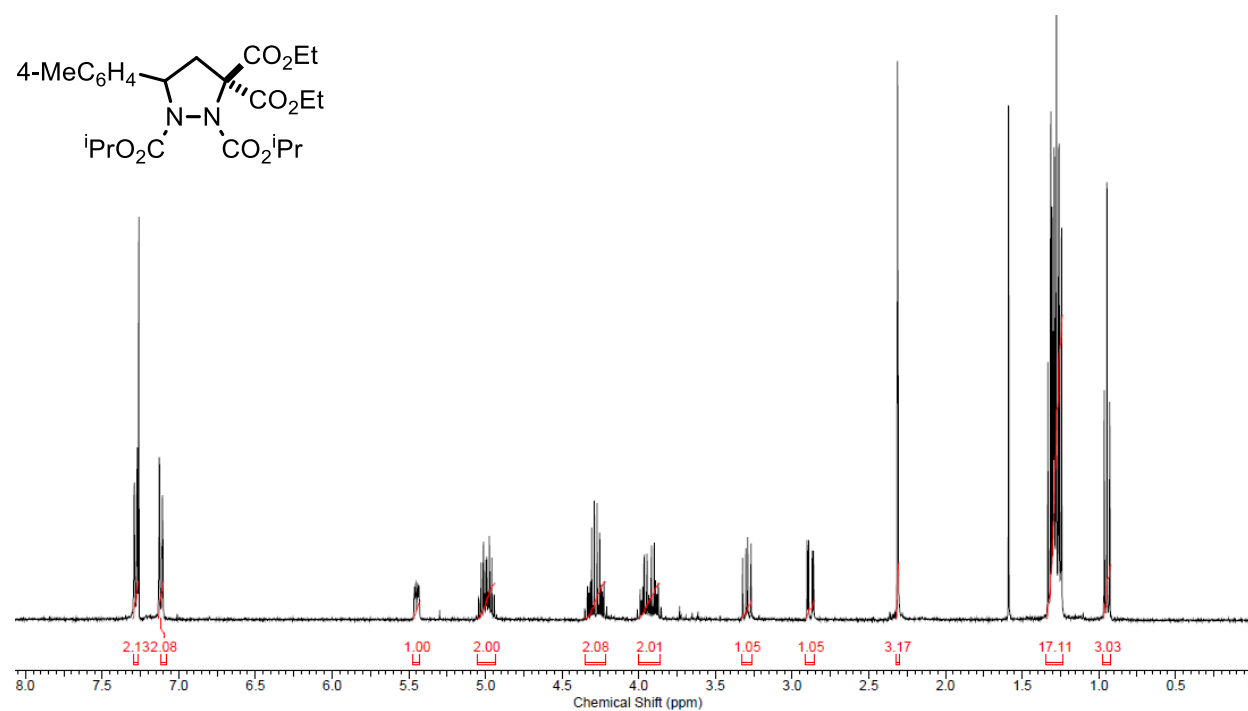
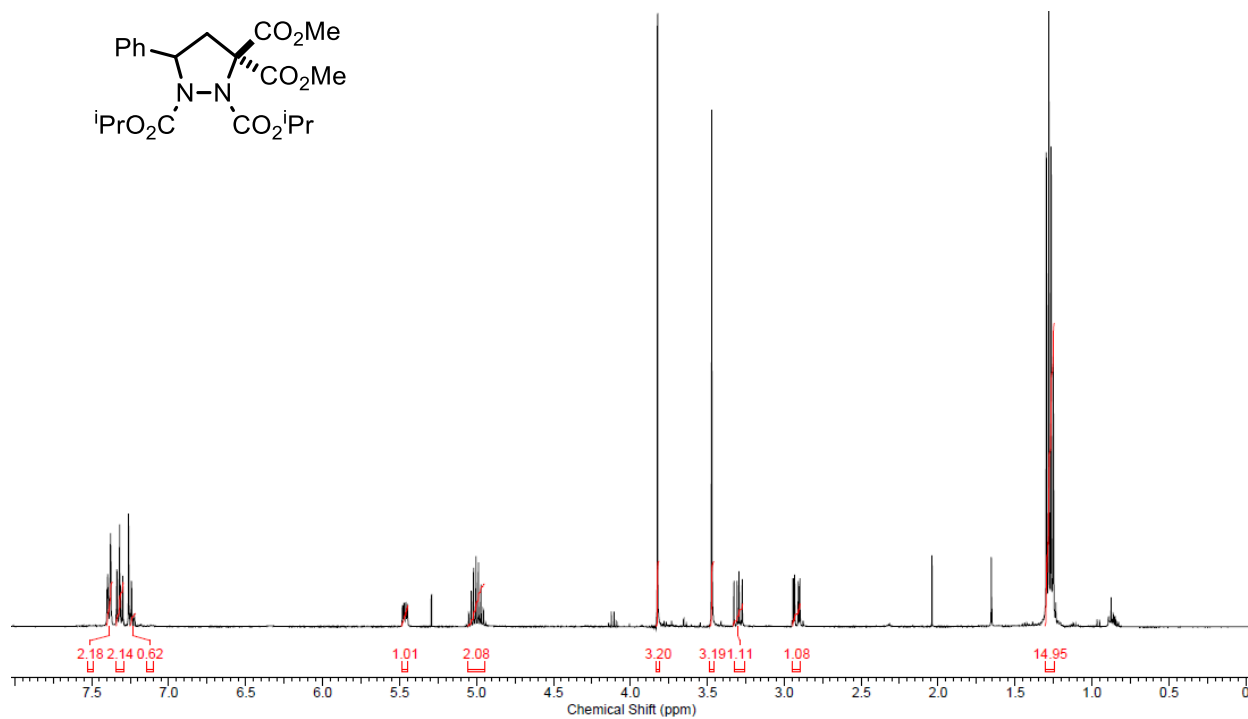

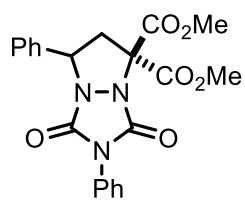

50a

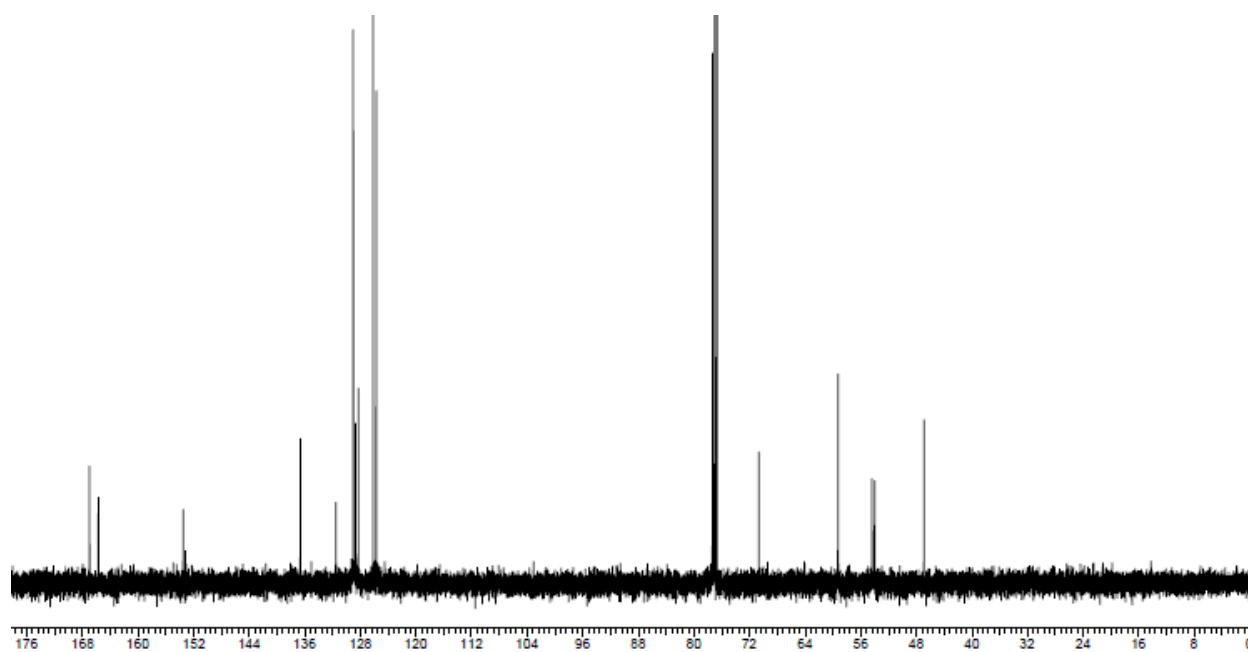
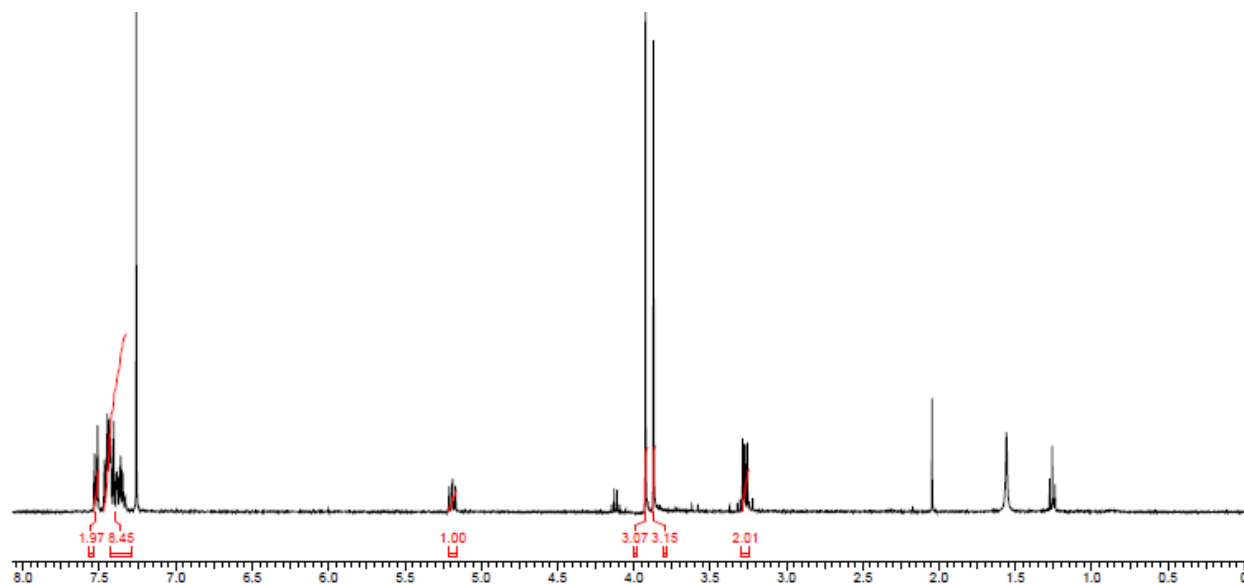

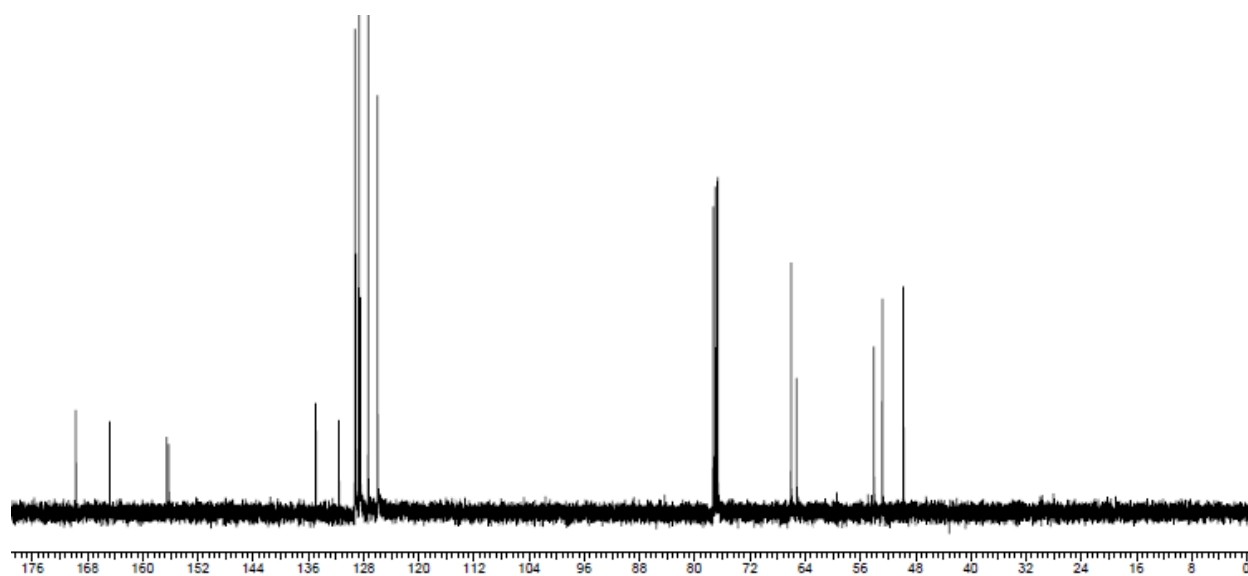
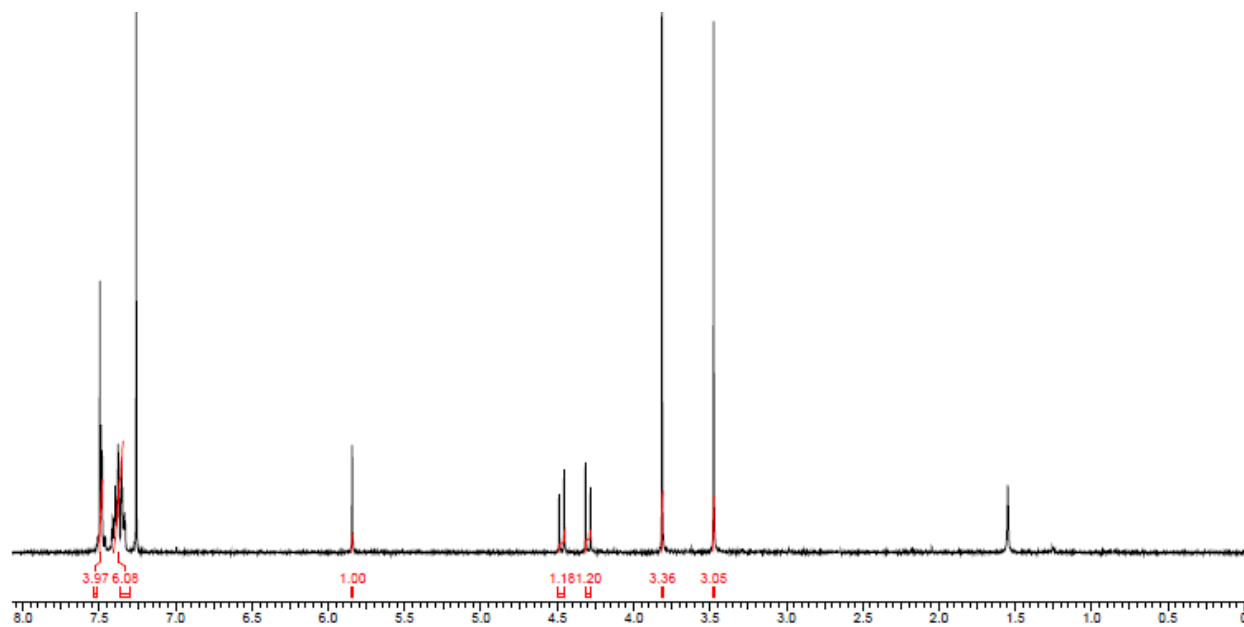
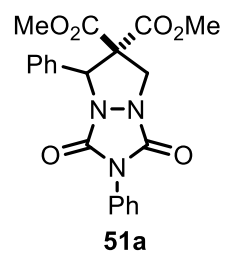

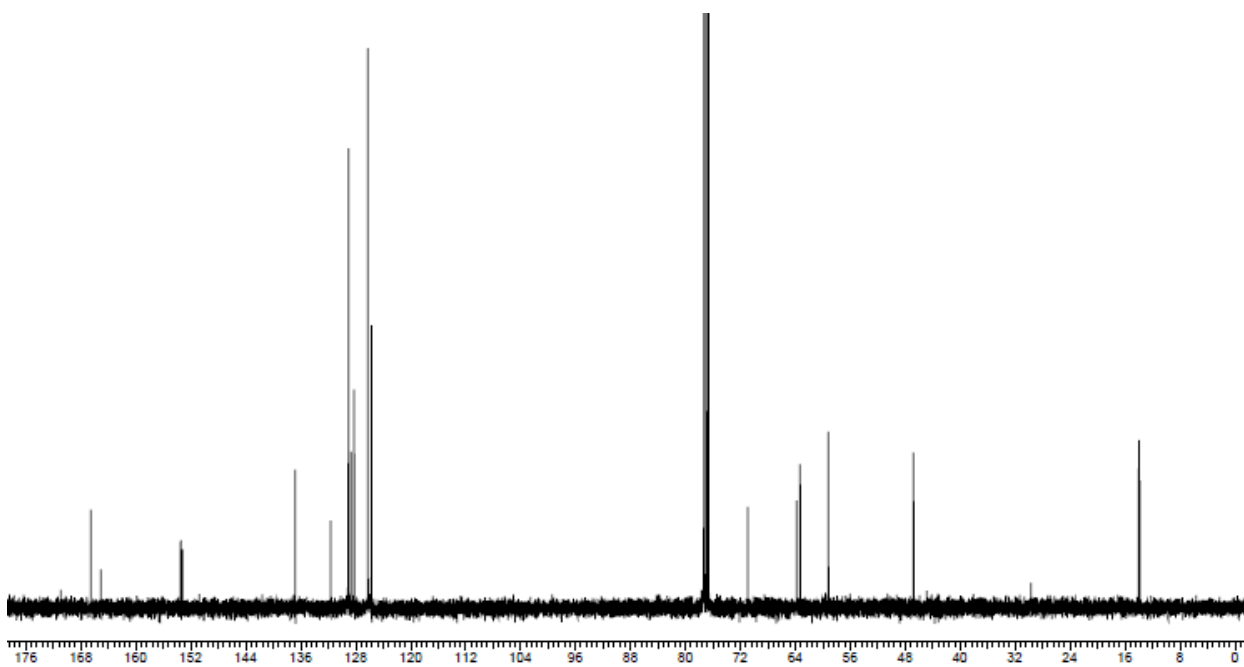
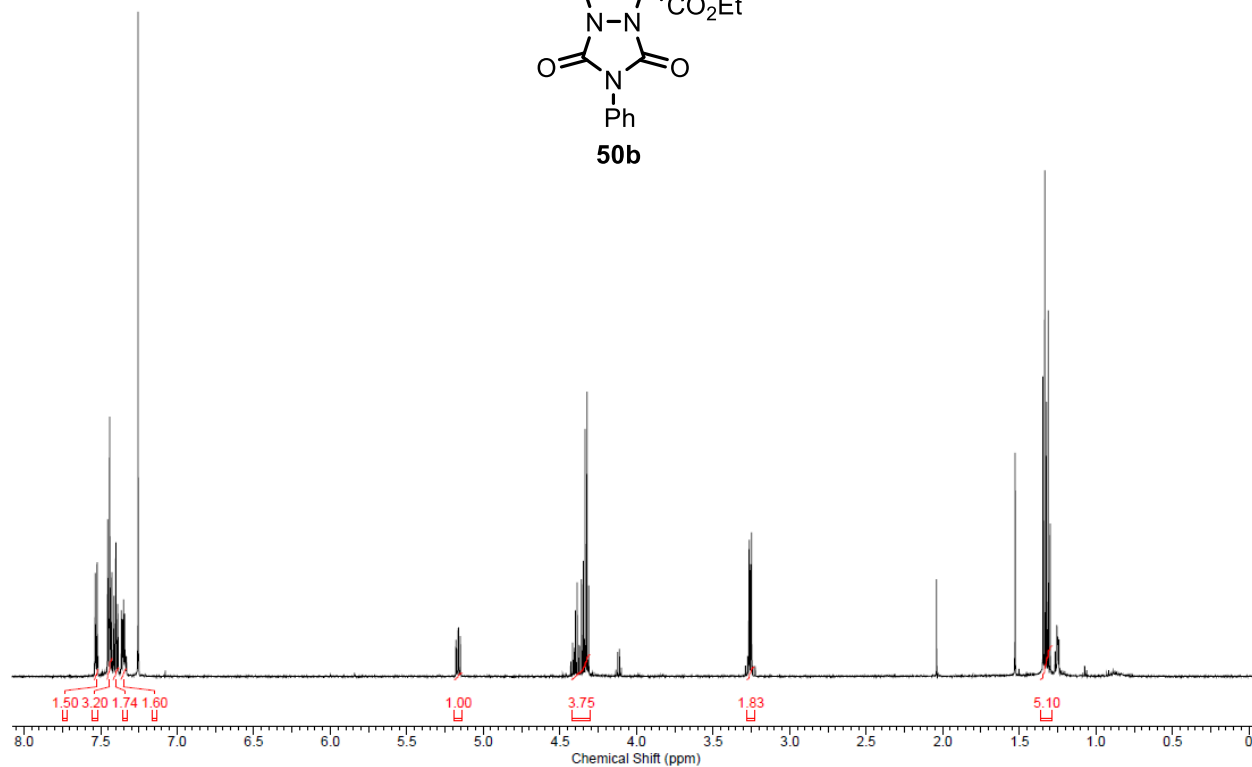
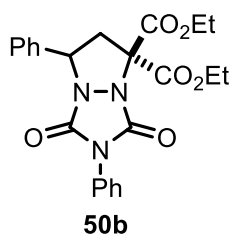

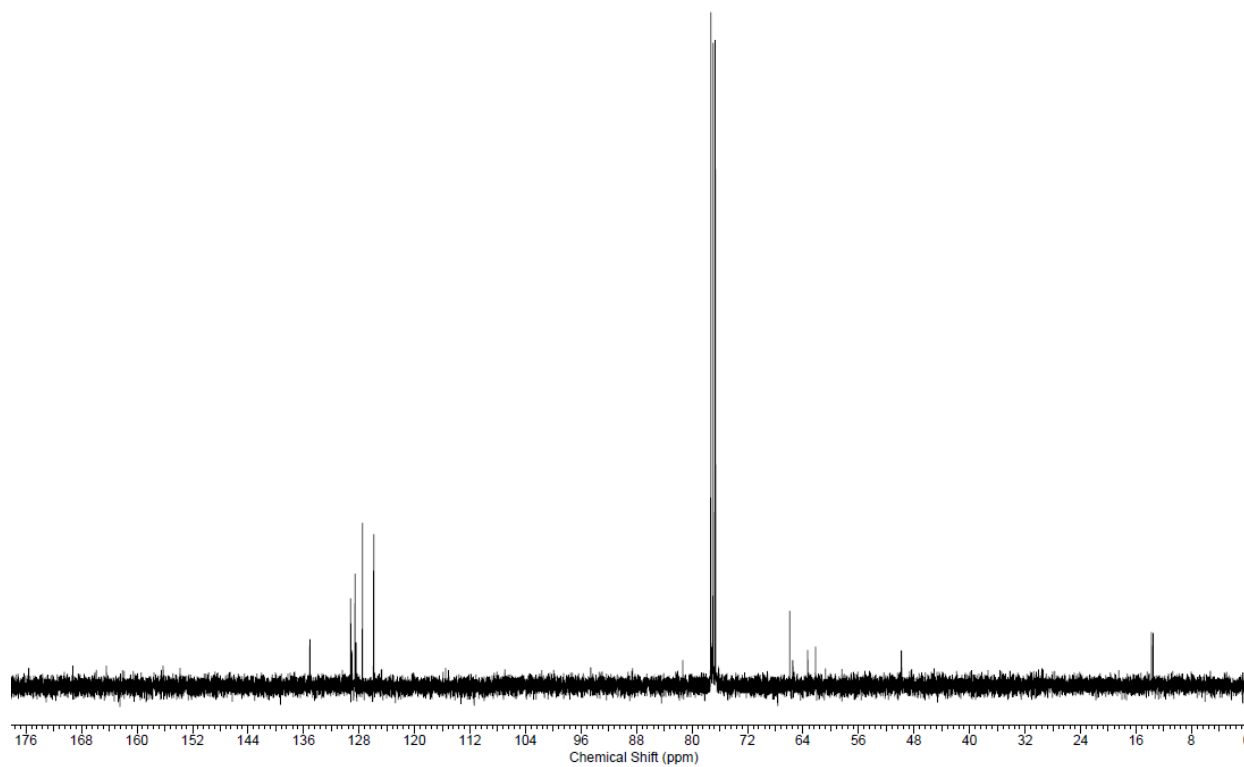
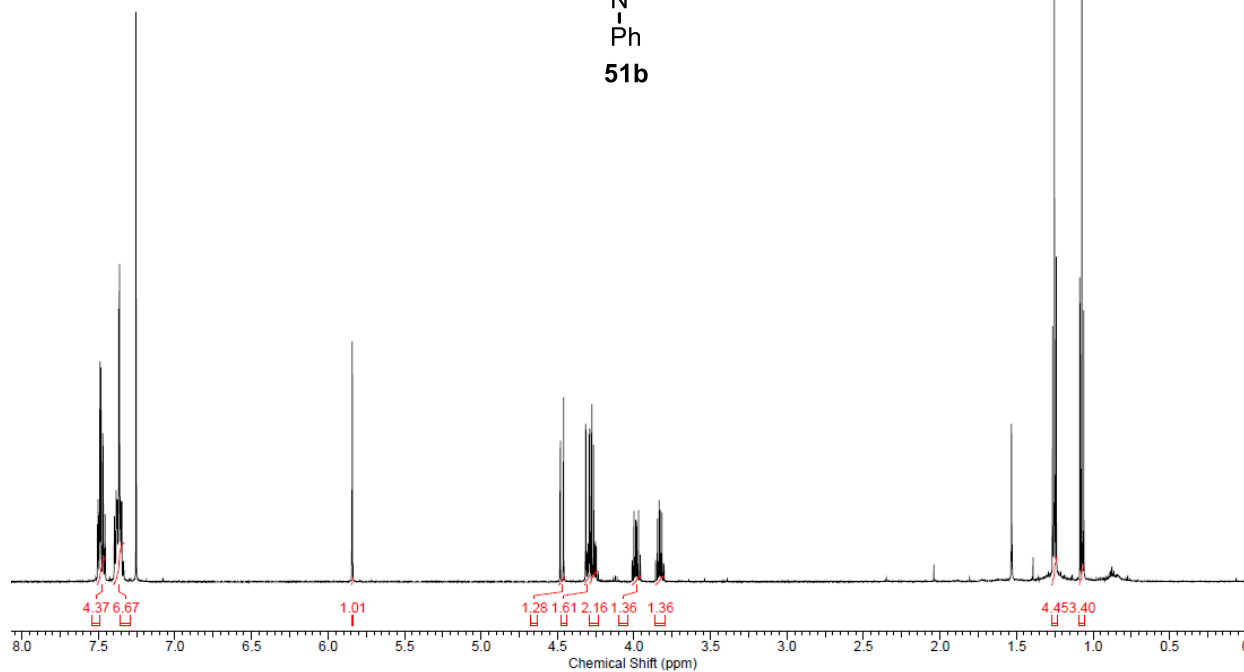
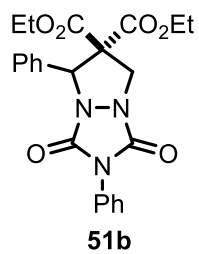

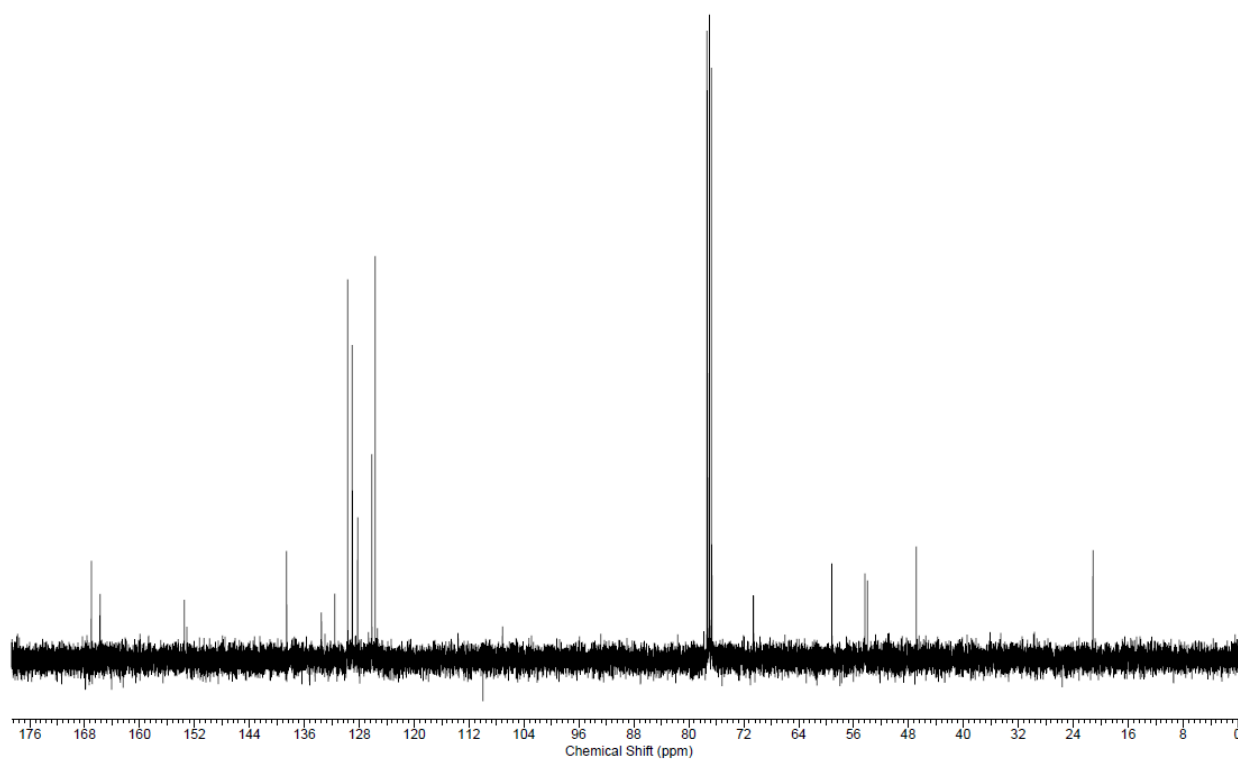
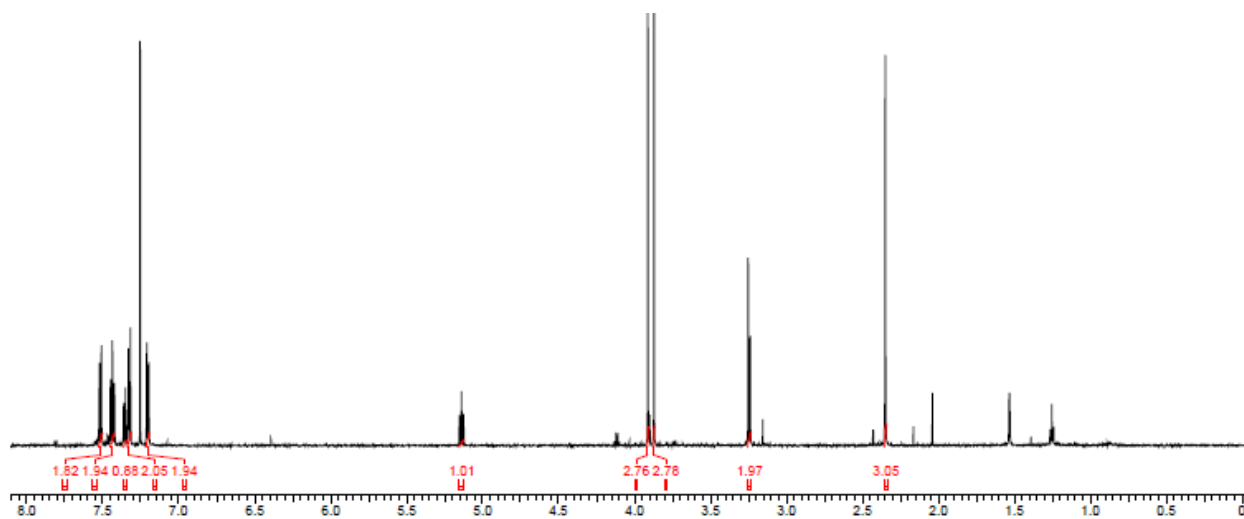
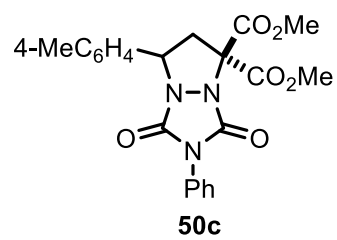

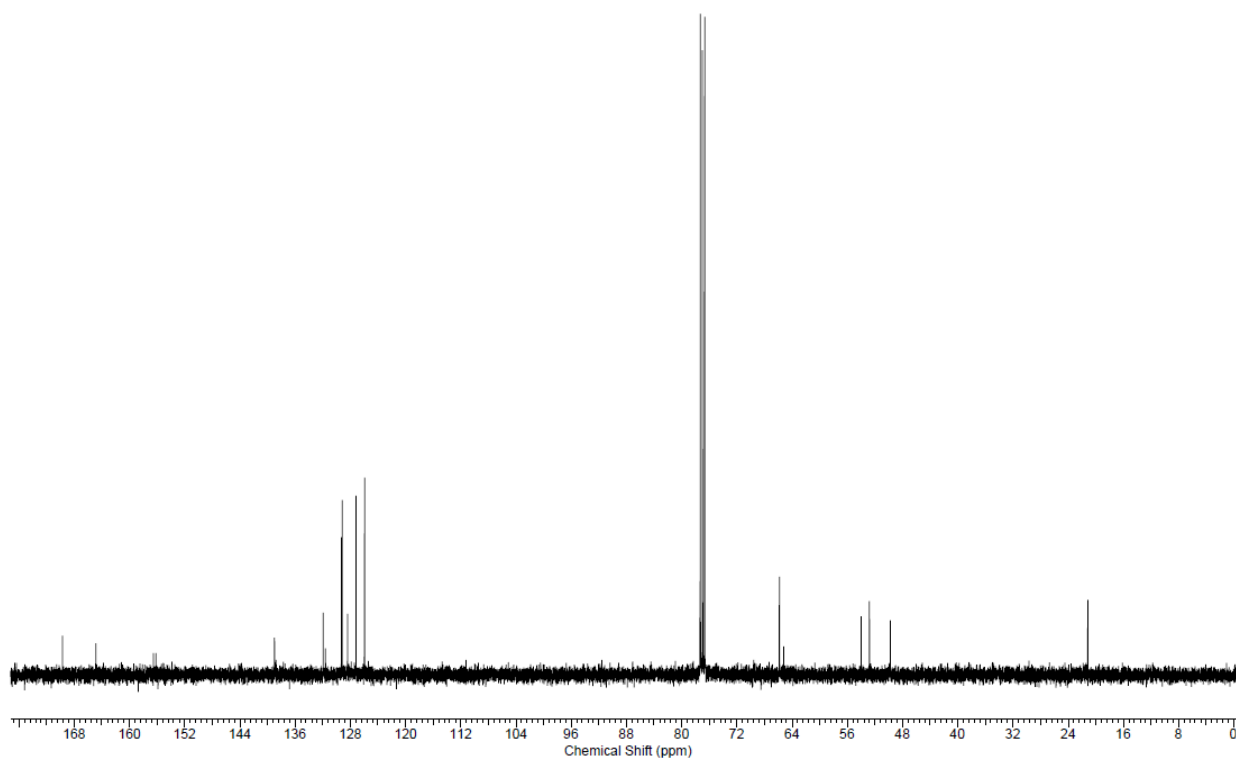
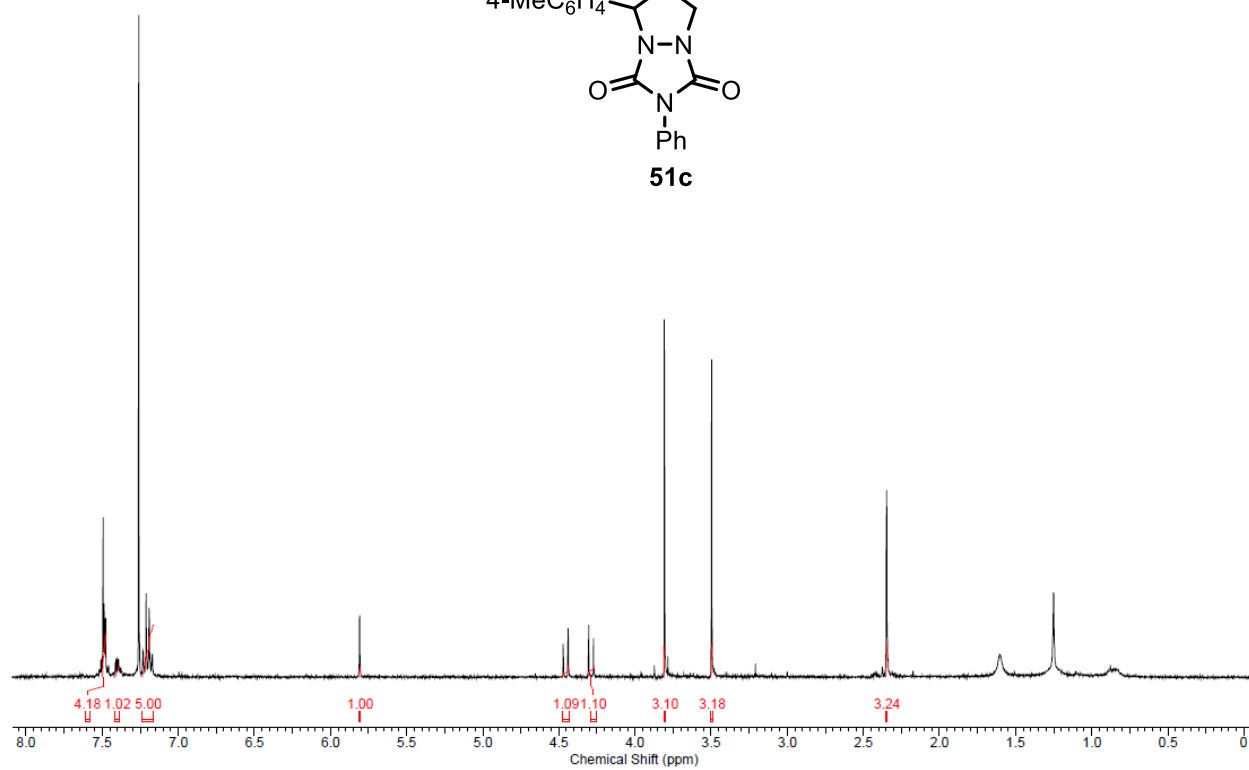
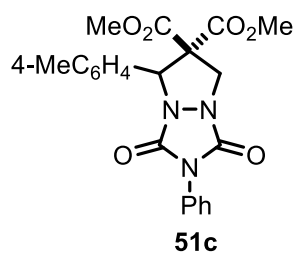

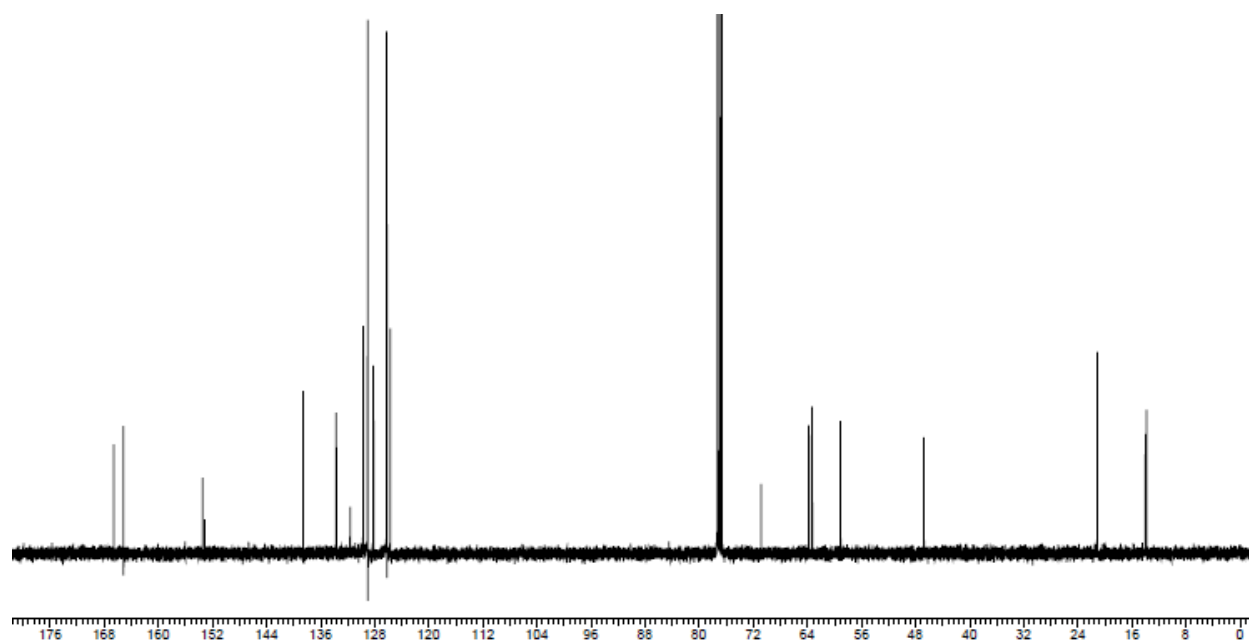
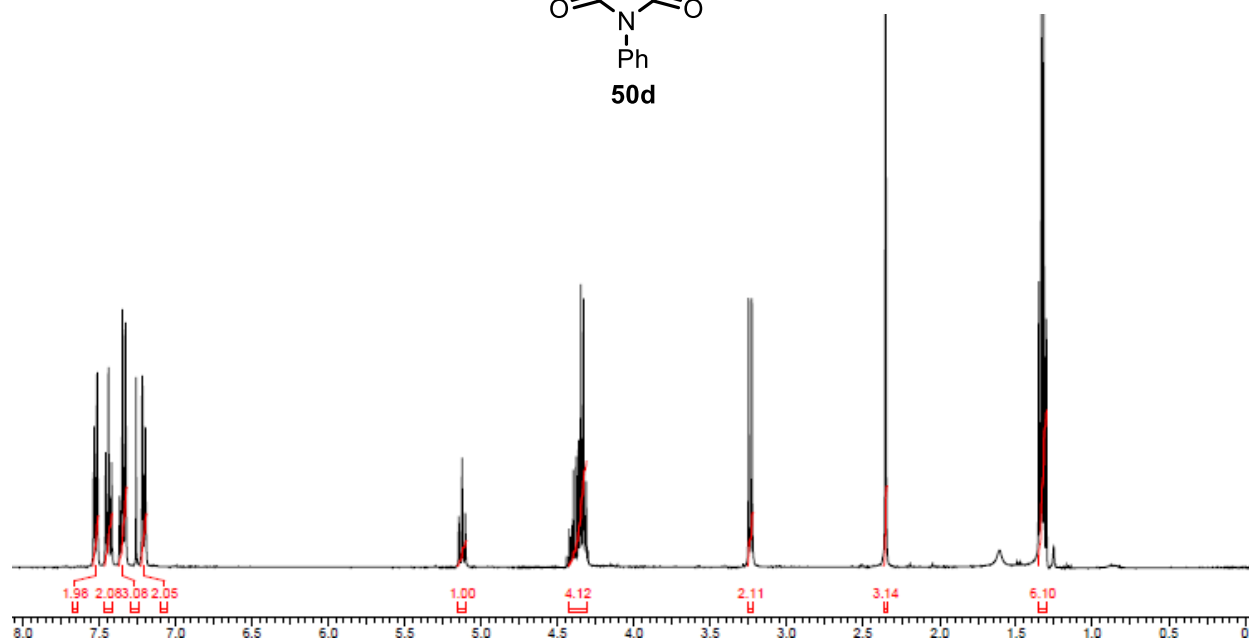
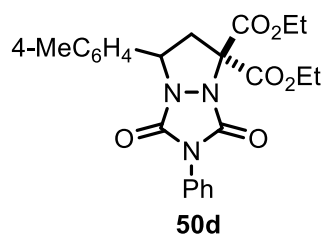

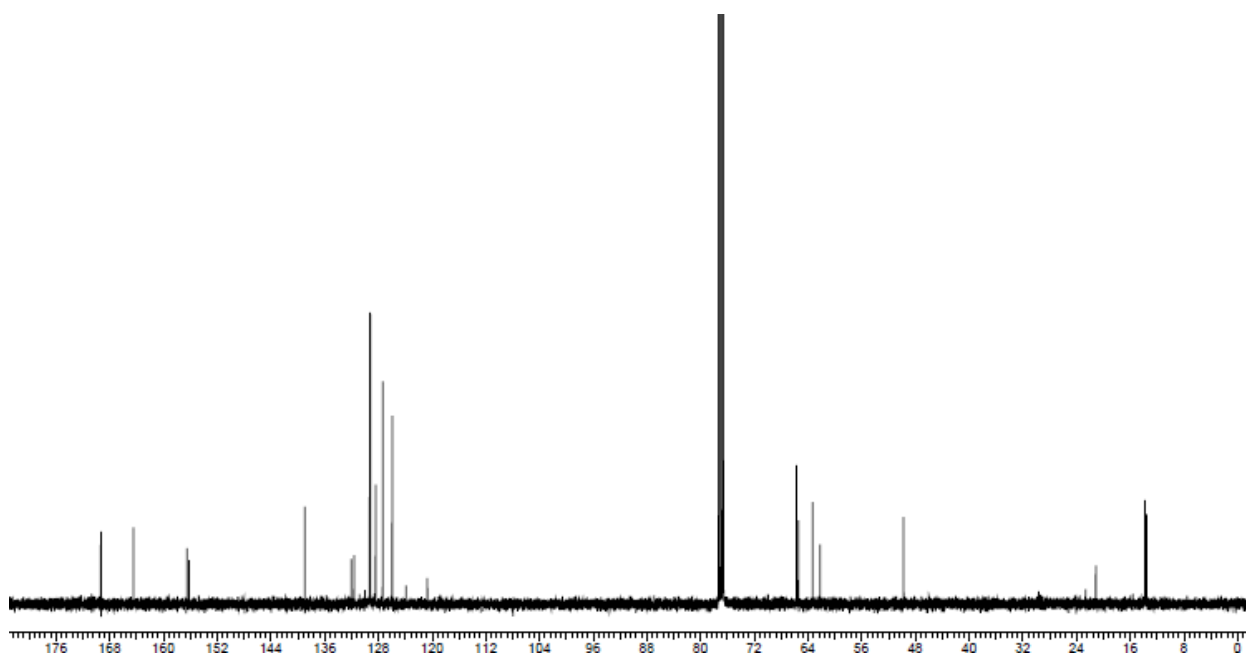
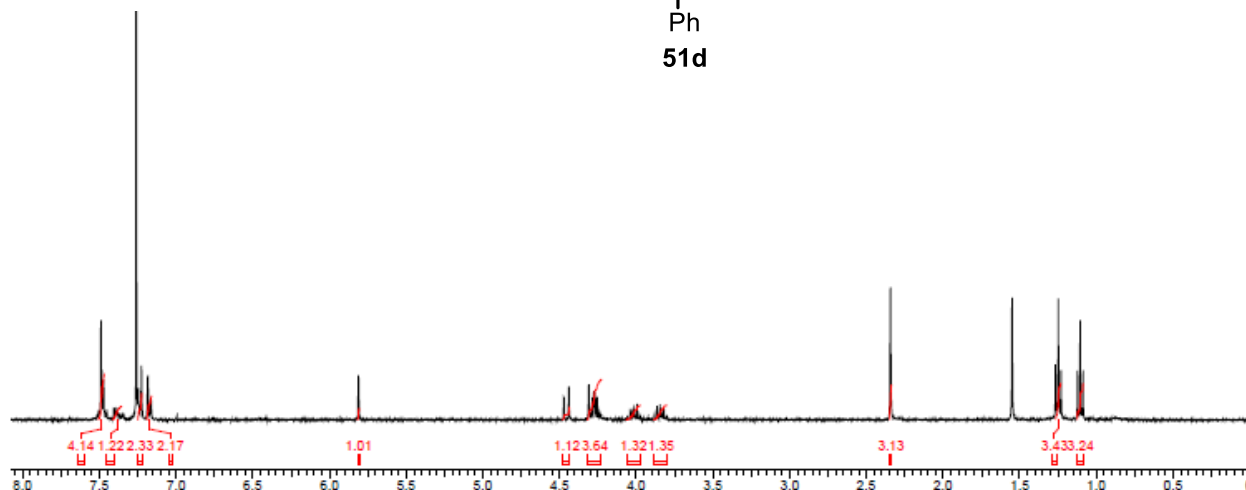
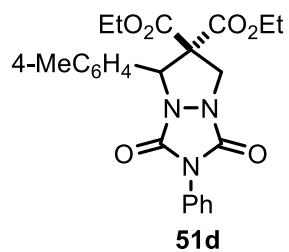

Appendix 3 - NMR Data Chapter 4

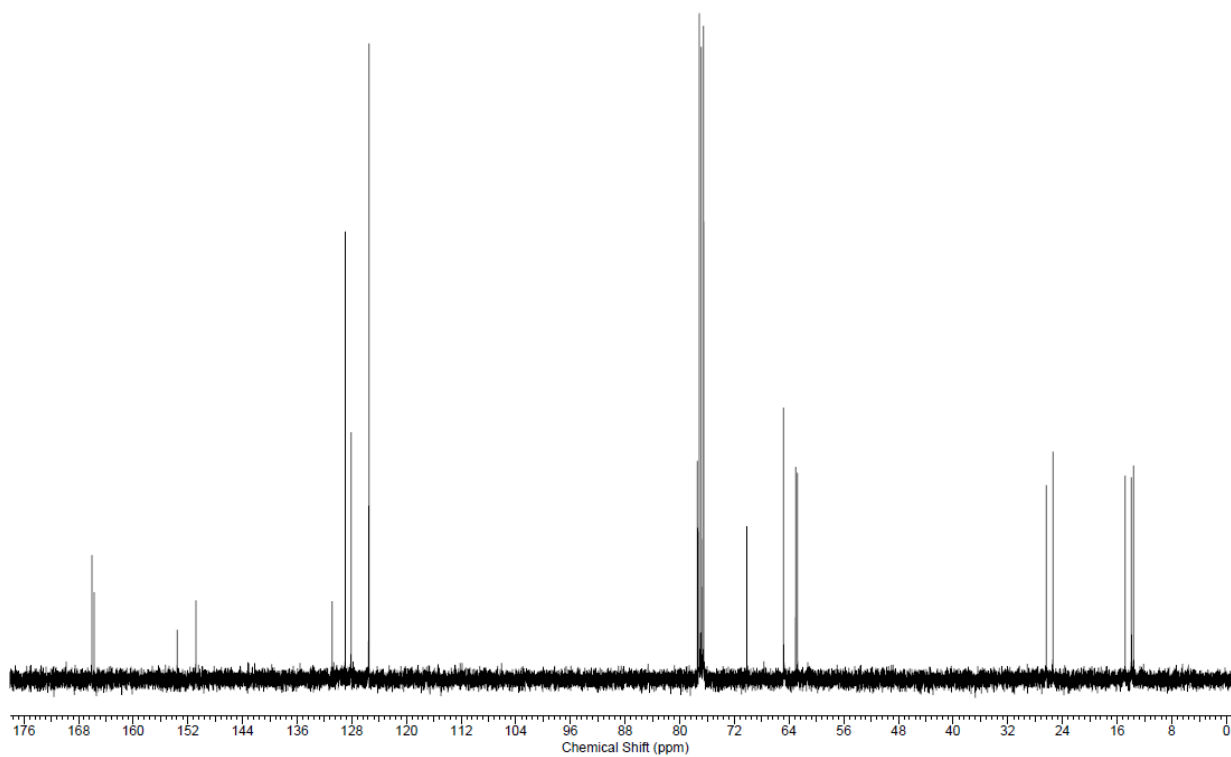
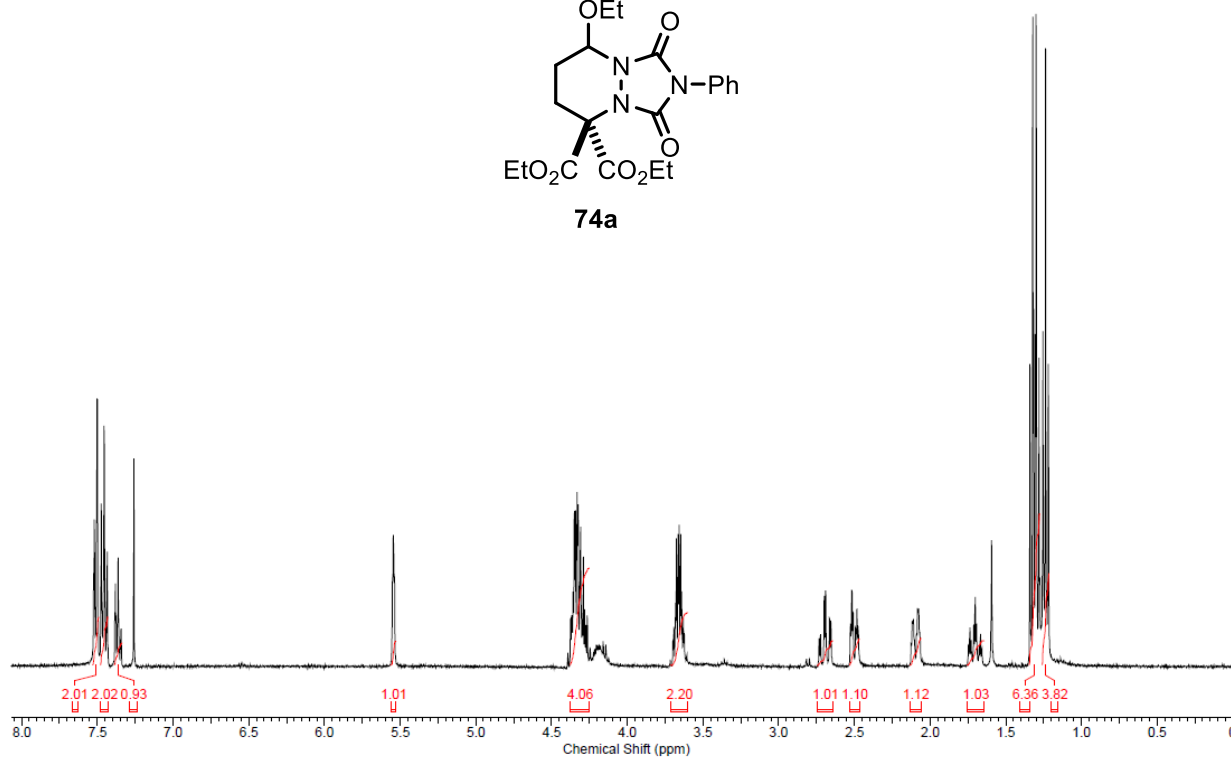
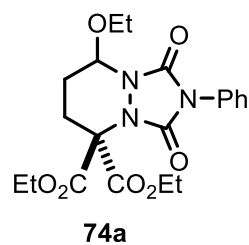

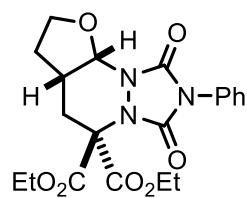

74b

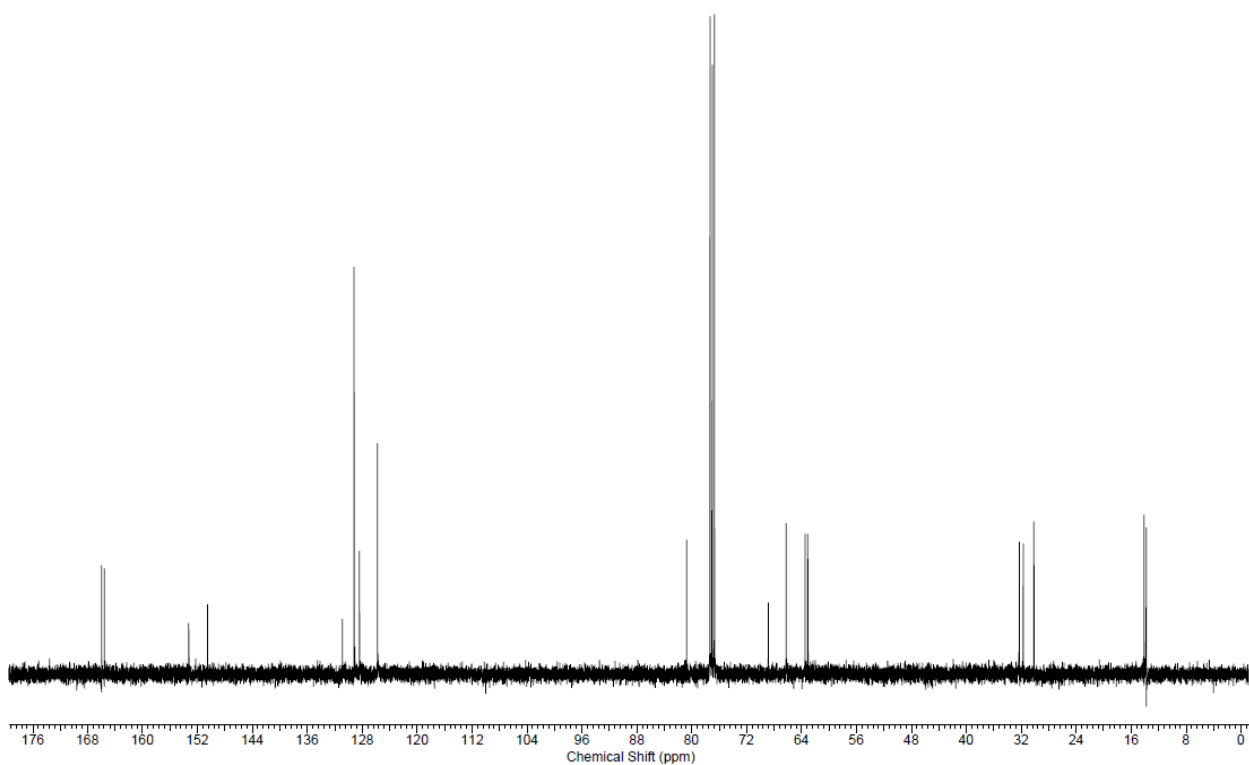
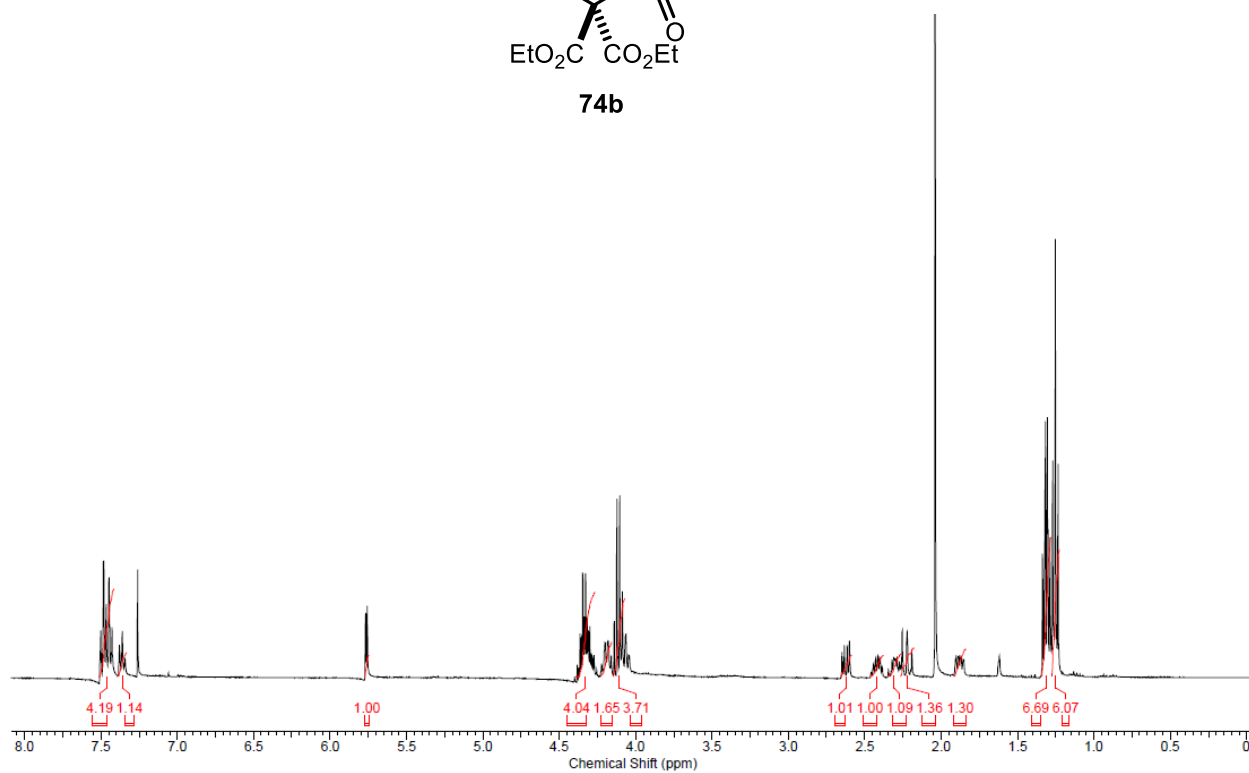

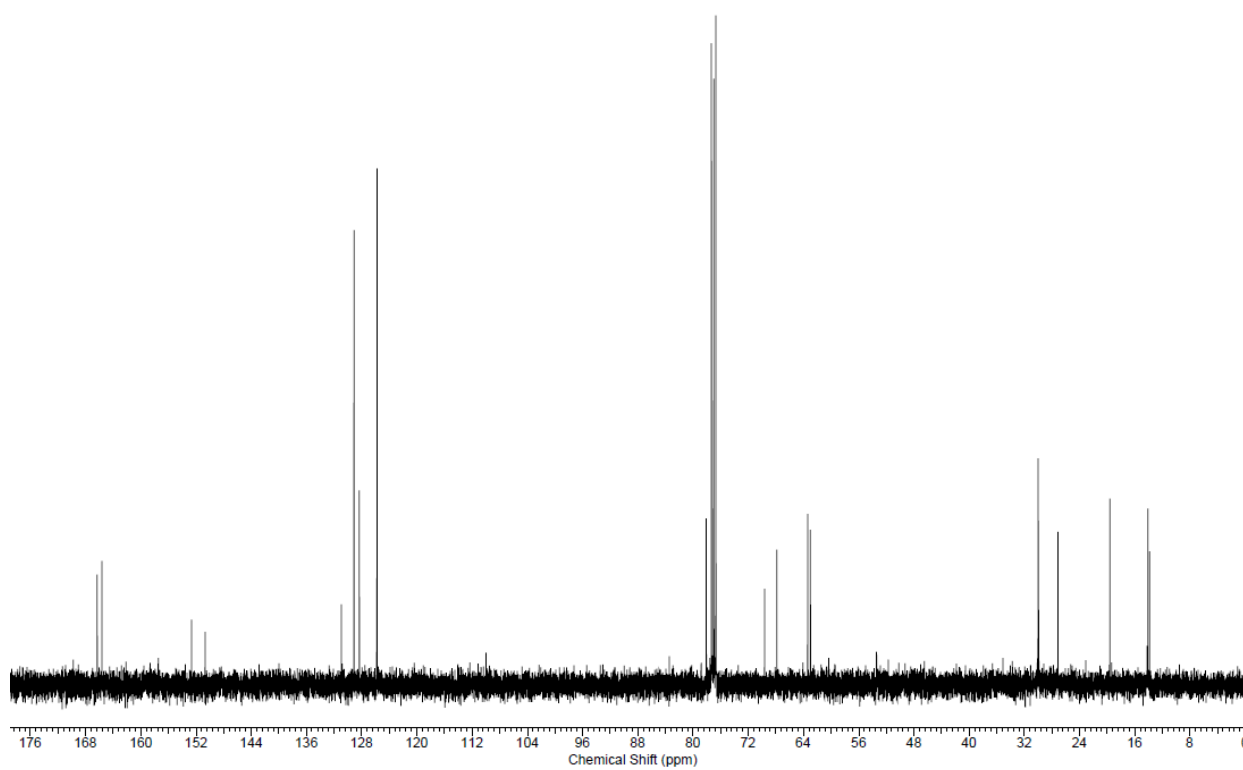
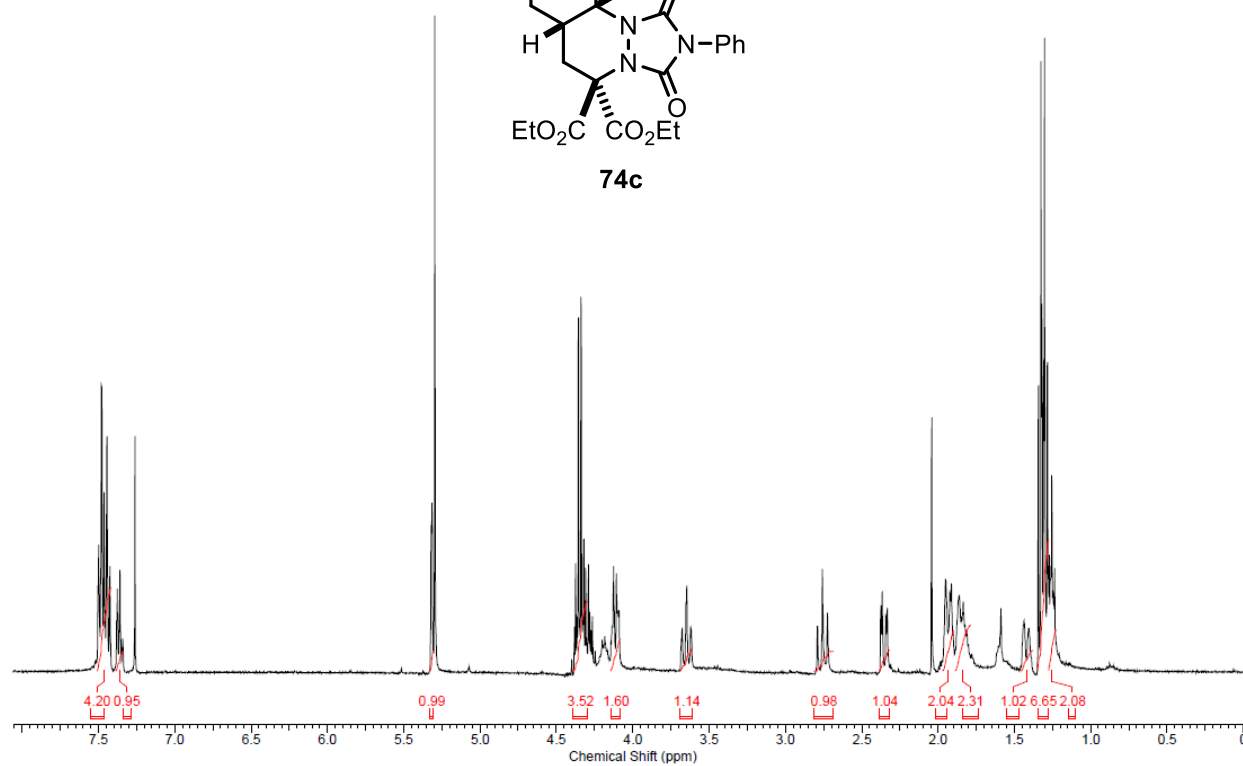
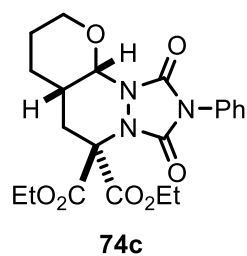

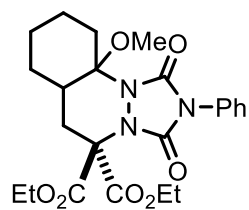

74d

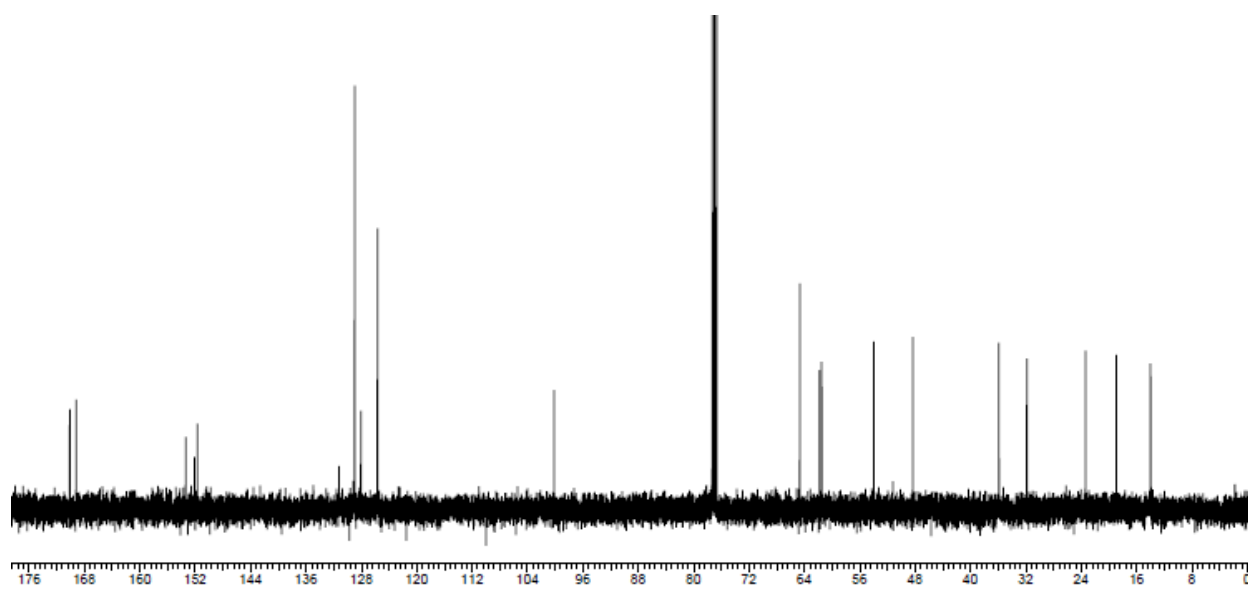
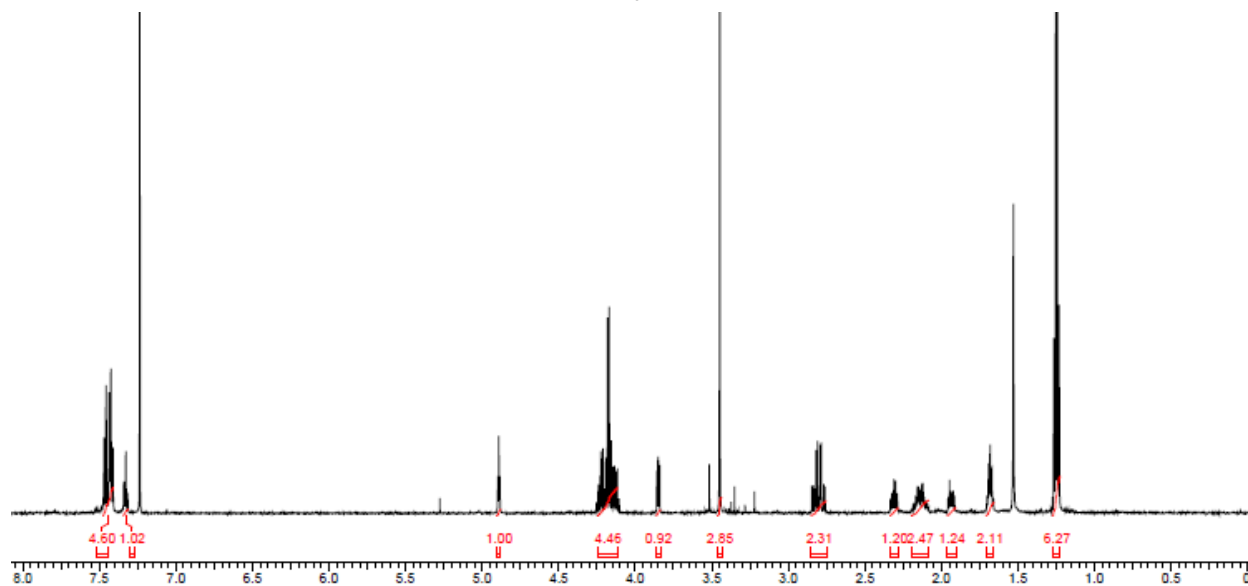

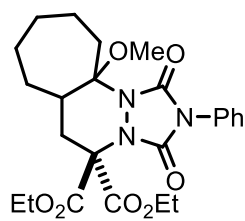

74e

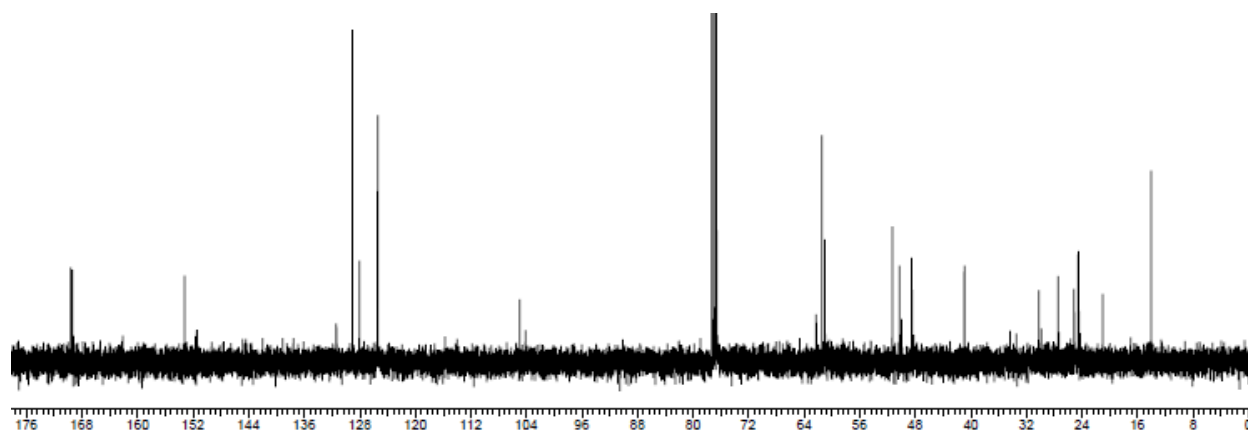
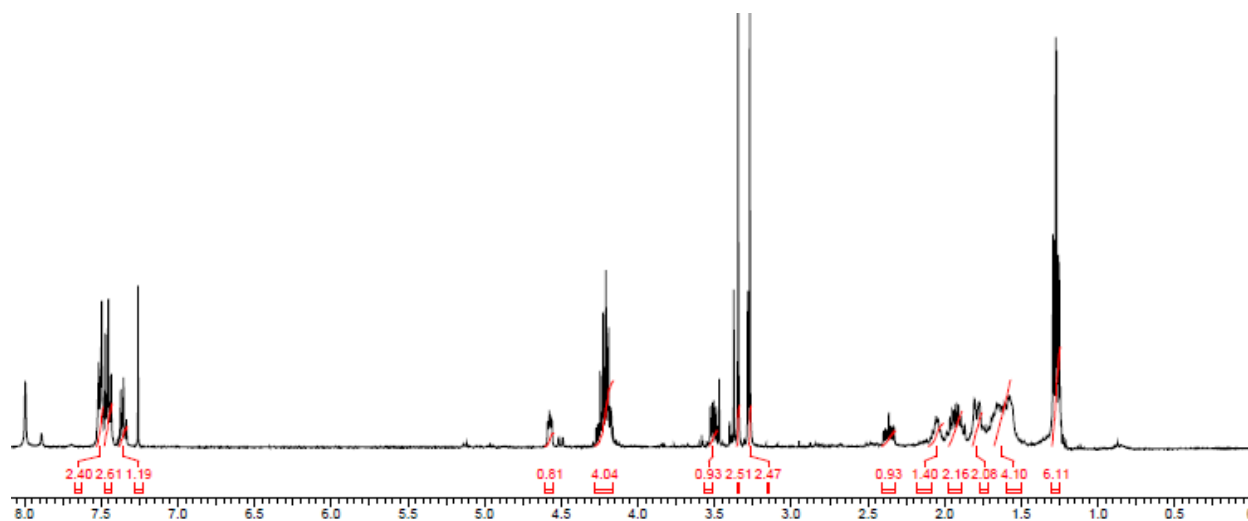

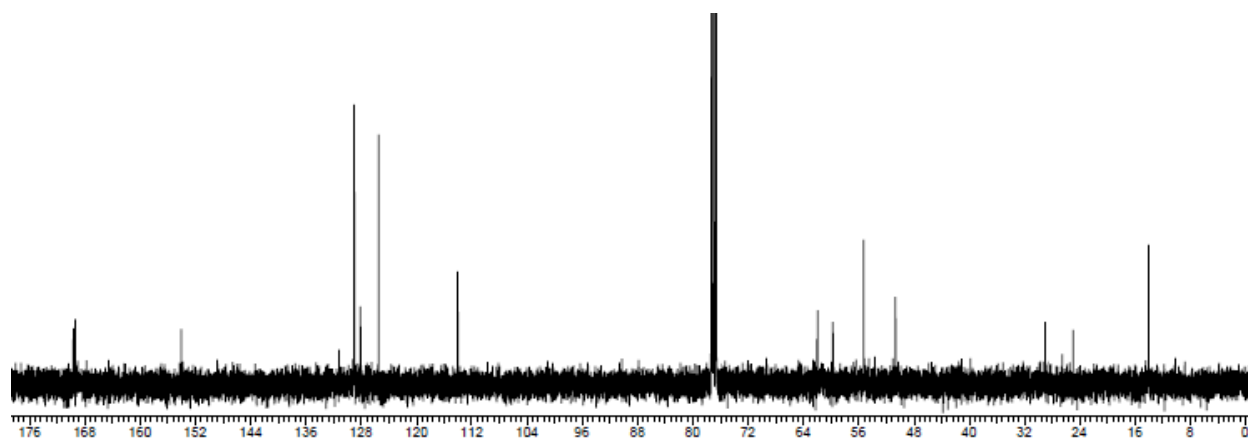
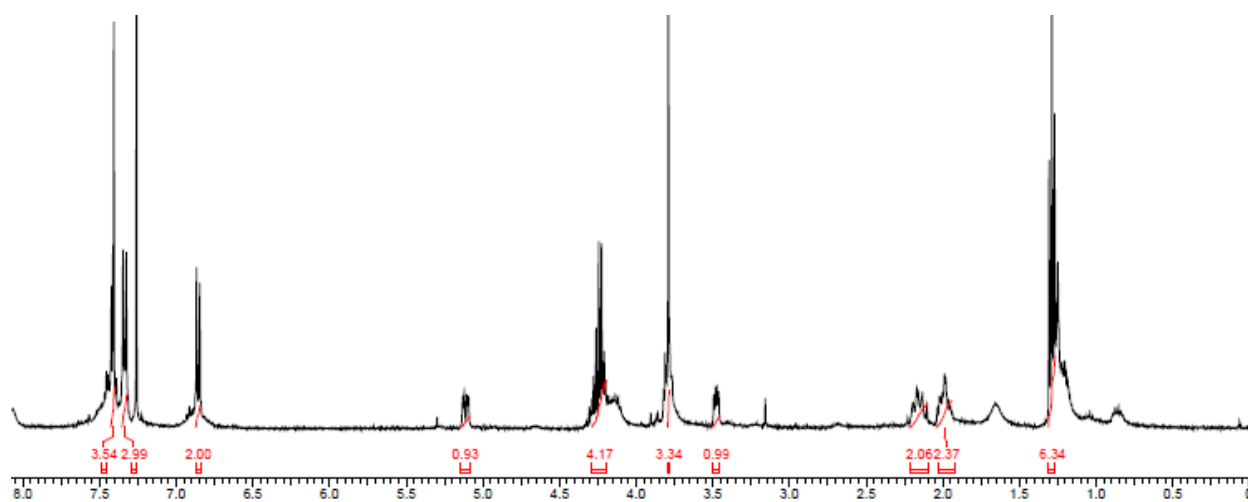
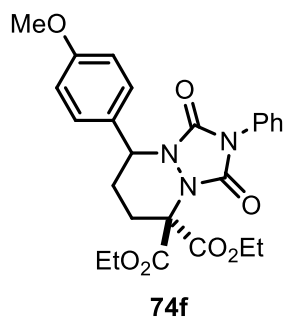

Appendix 4 - GC-MS Data Chapter 2

Standards

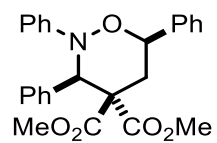
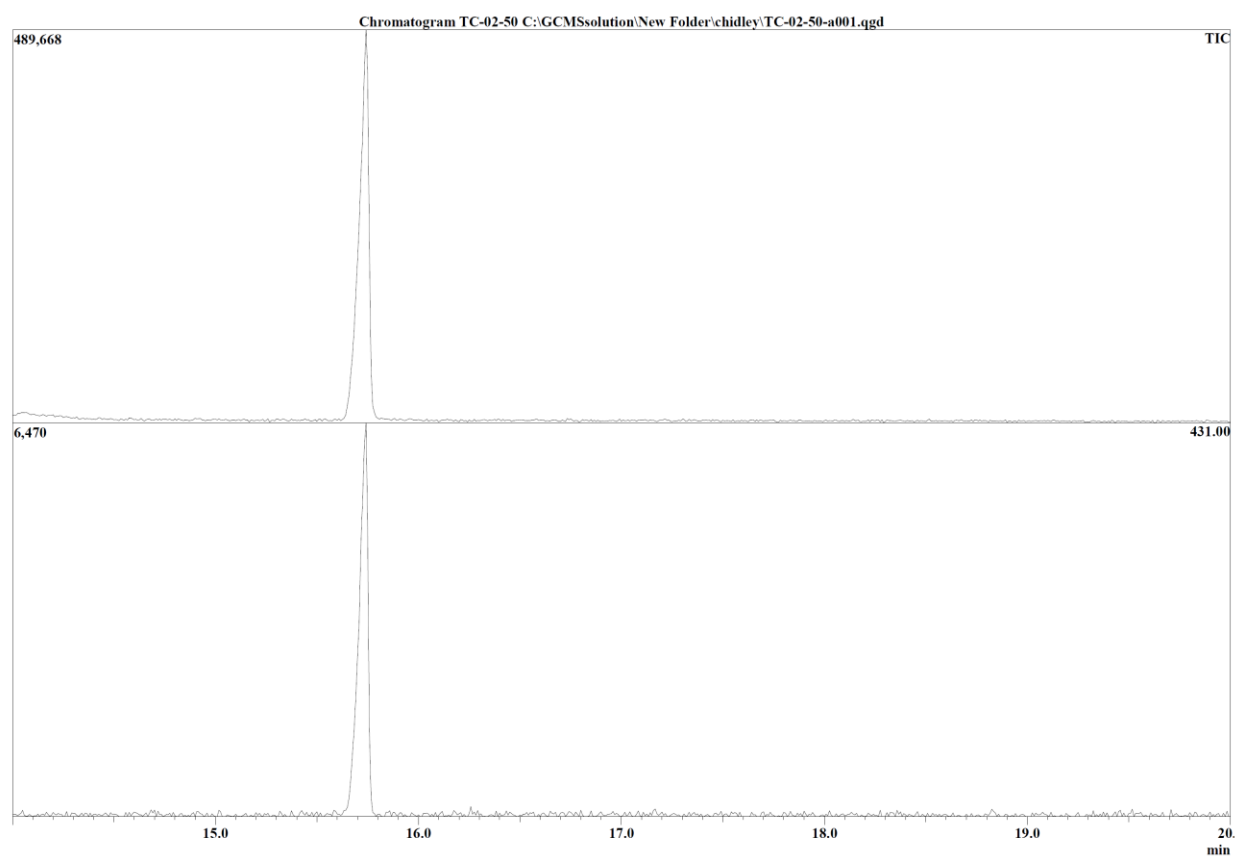
**35a****431.48 g/mol****15.742 min**

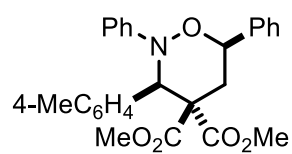
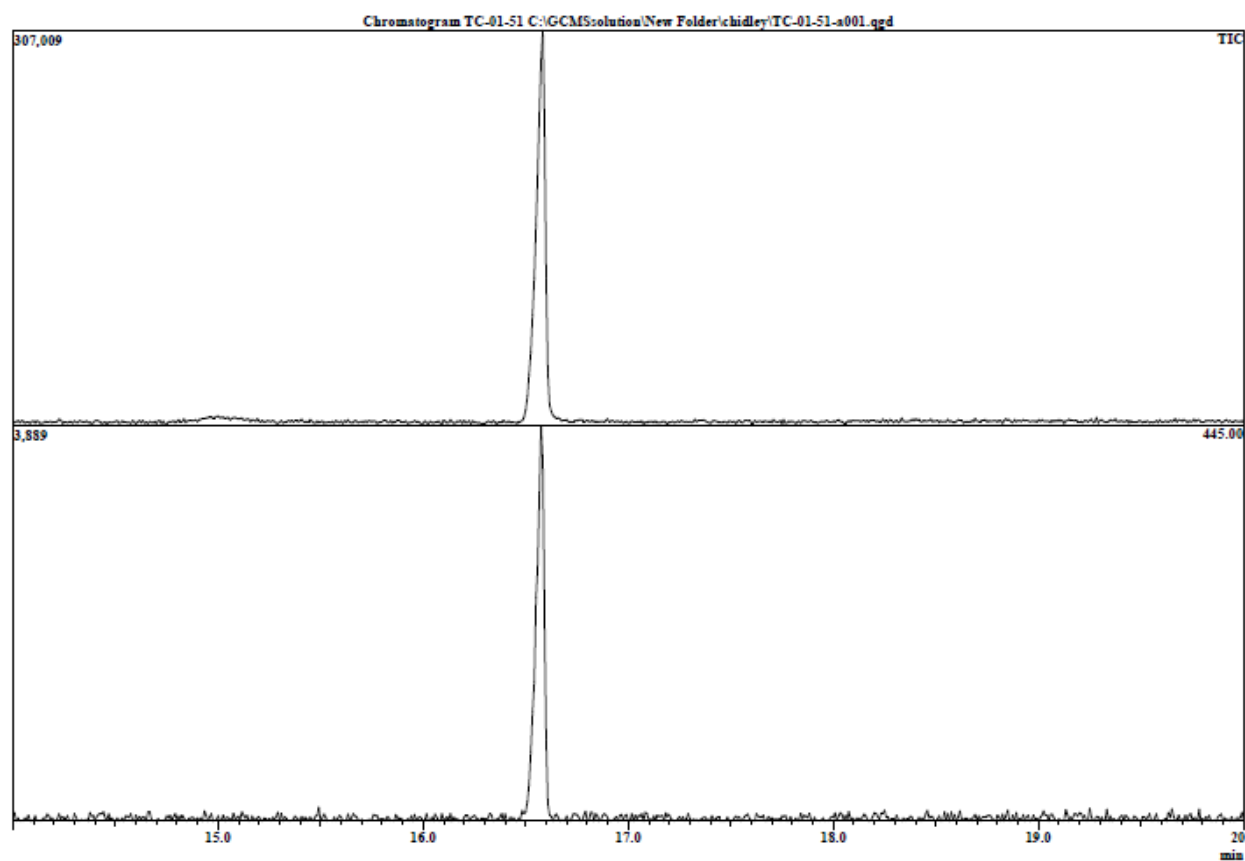
**35b****445.51 g/mol****16.581 min**

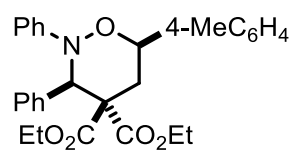
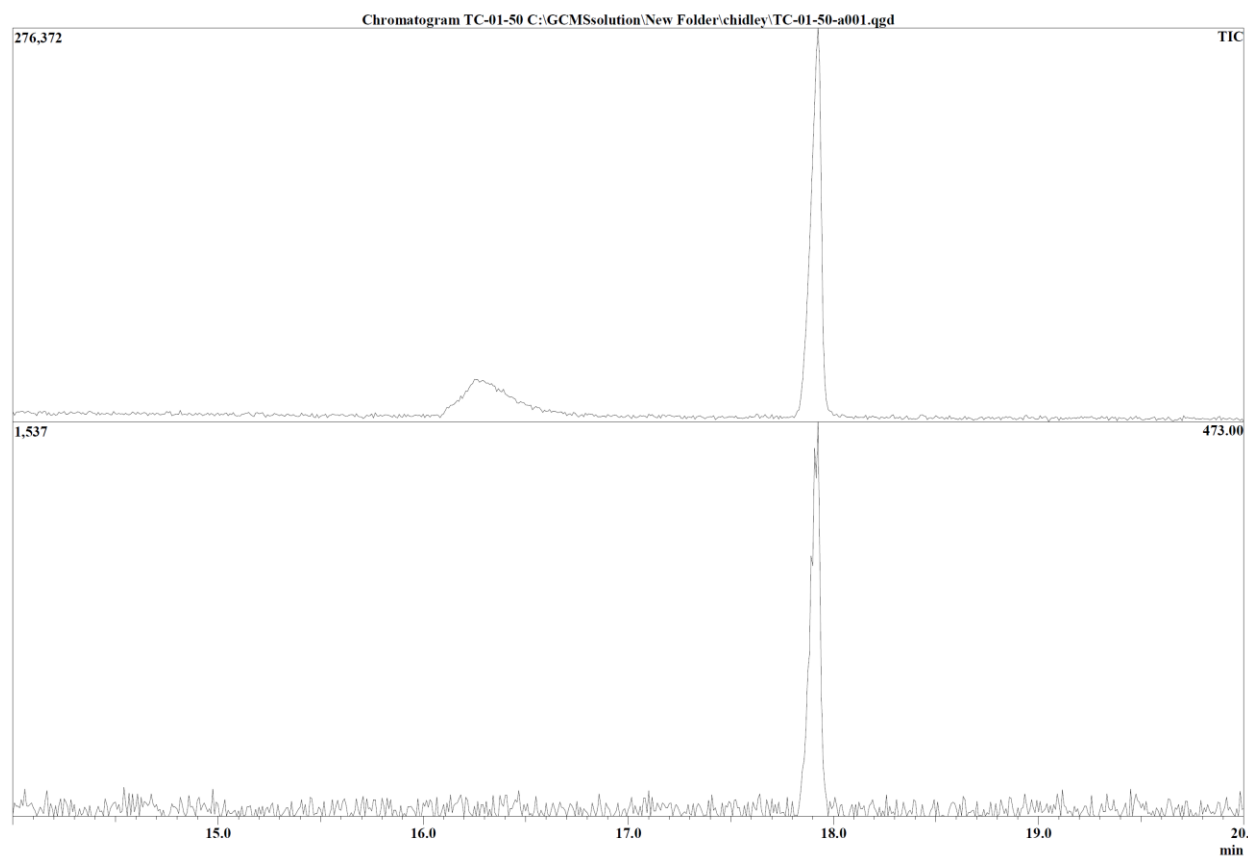
**35c****473.56 g/mol****17.925 min**

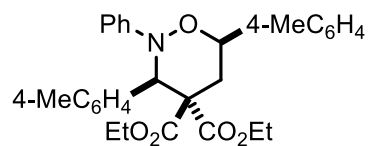
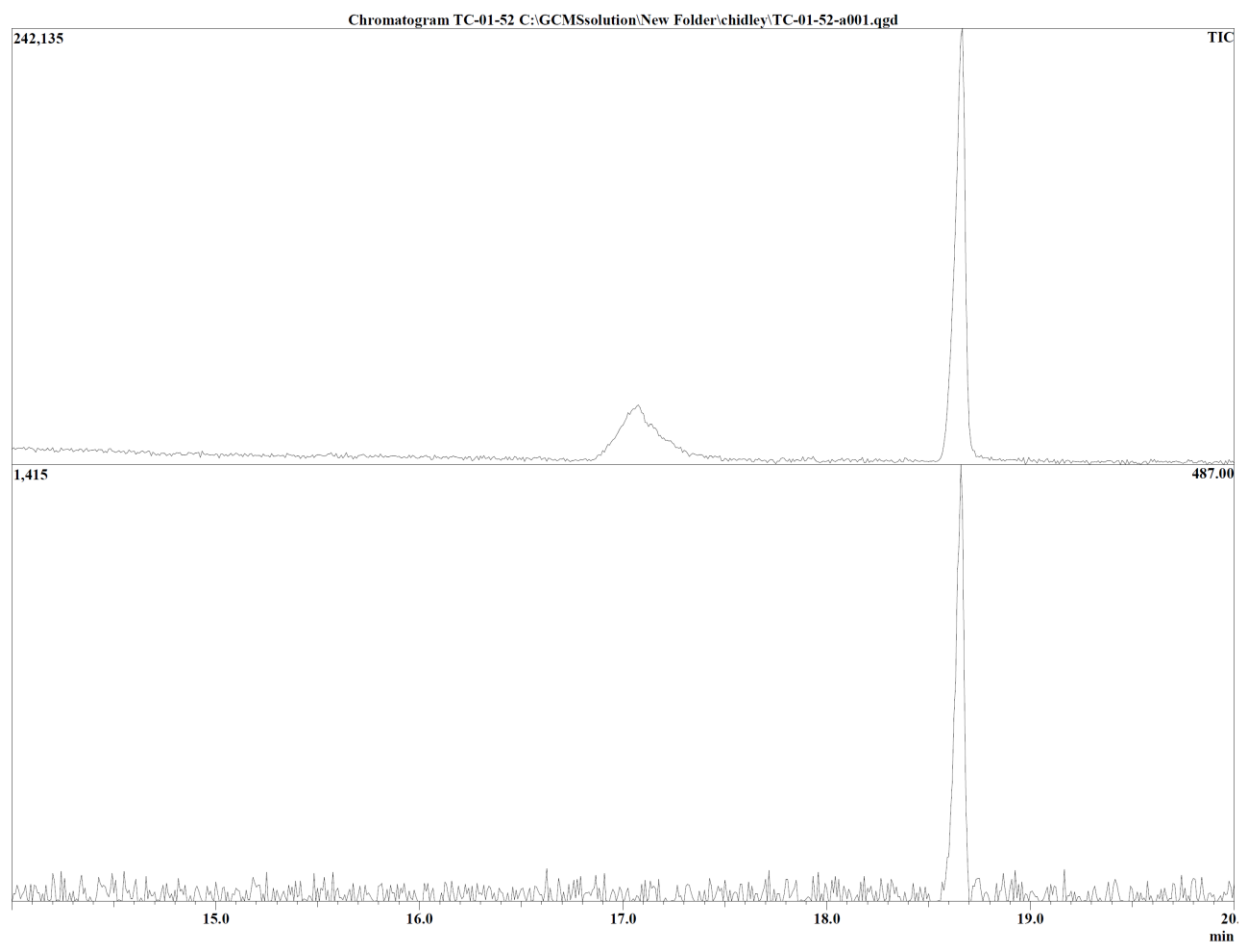
**35d****487.59 g/mol****18.663 min**

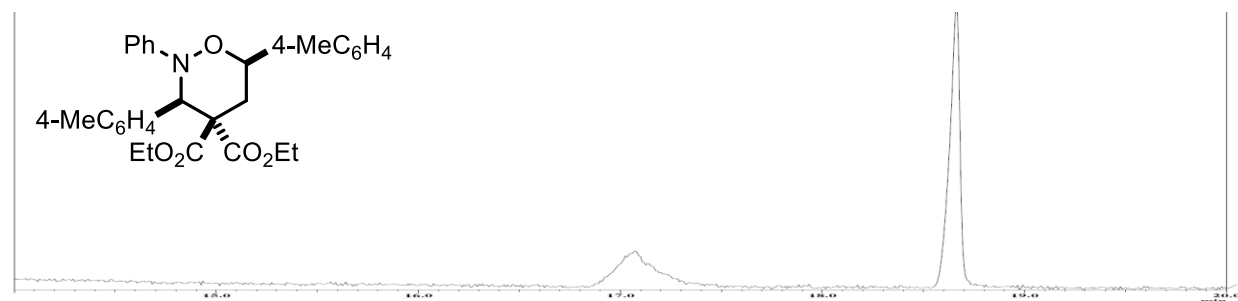
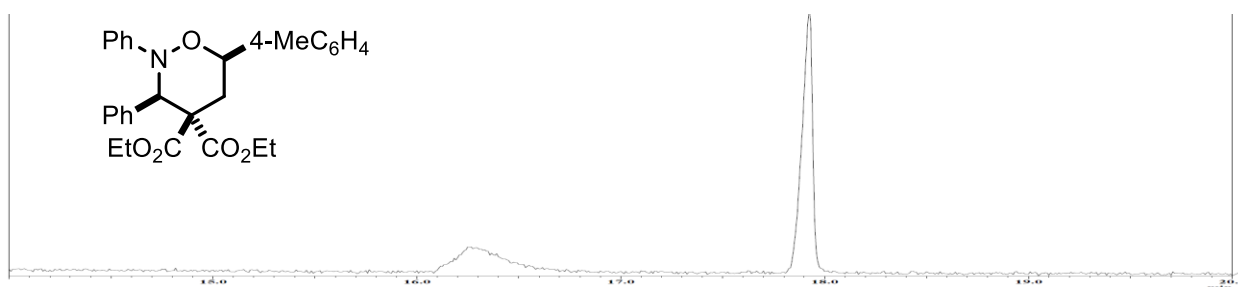
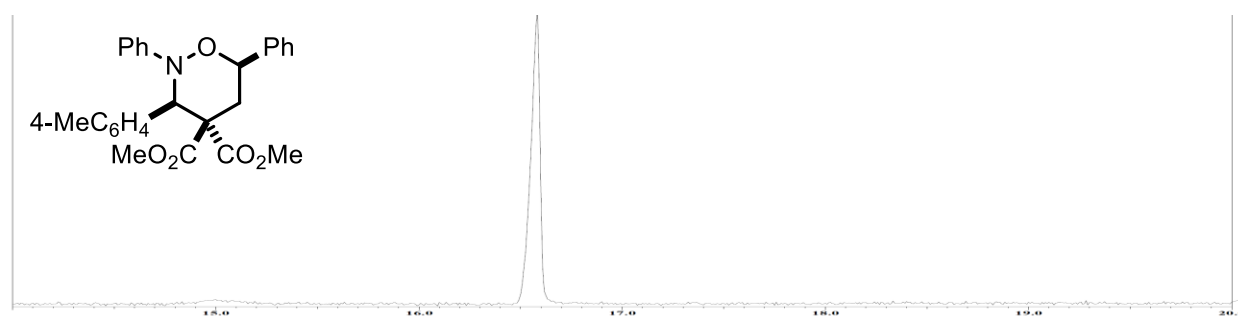

Cross-Over Experiment #1

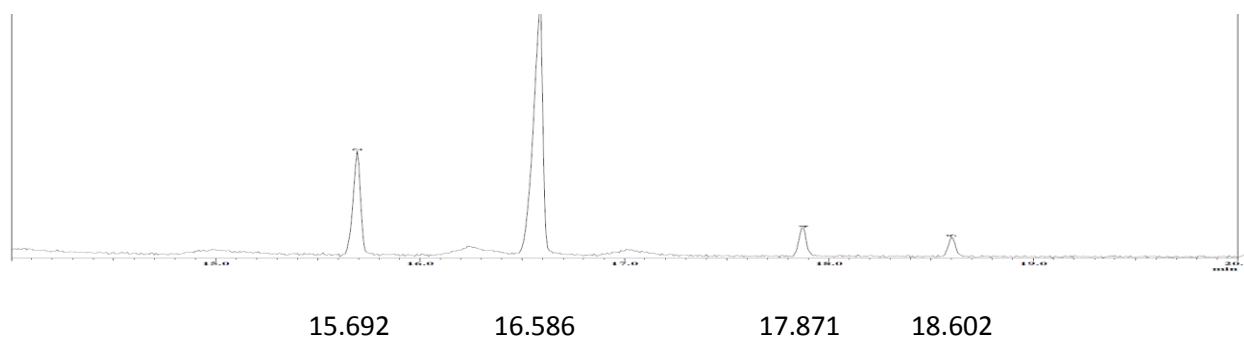

Cross-Over Experiment #1

SCAN GRAPH. Flagging=Low Resolution M/z. Highlighting=Base Peak.

Scan 125#9:31.25 - 140#10:39.91. Entries=978. Base M/z=212. 100% Int.=37.0247.

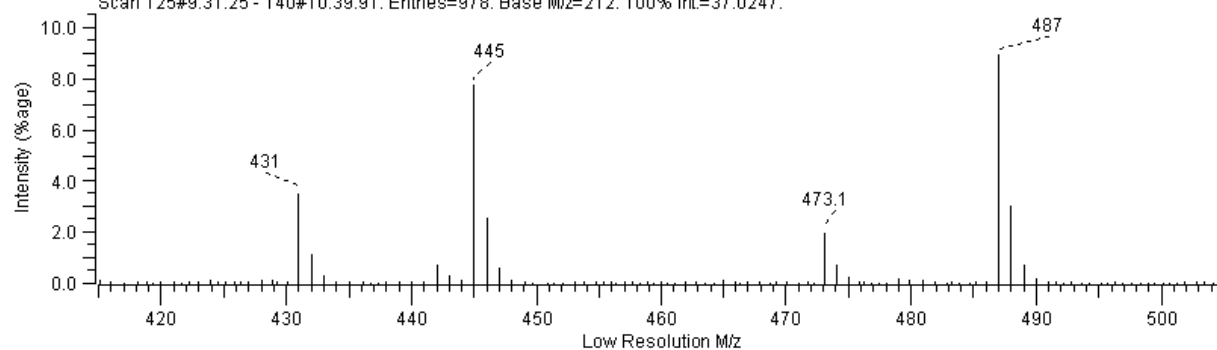

Appendix 5 - GC-MS Data Chapter 3

Standards

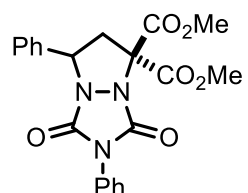

50a

409.39 g/mol

17.497 min

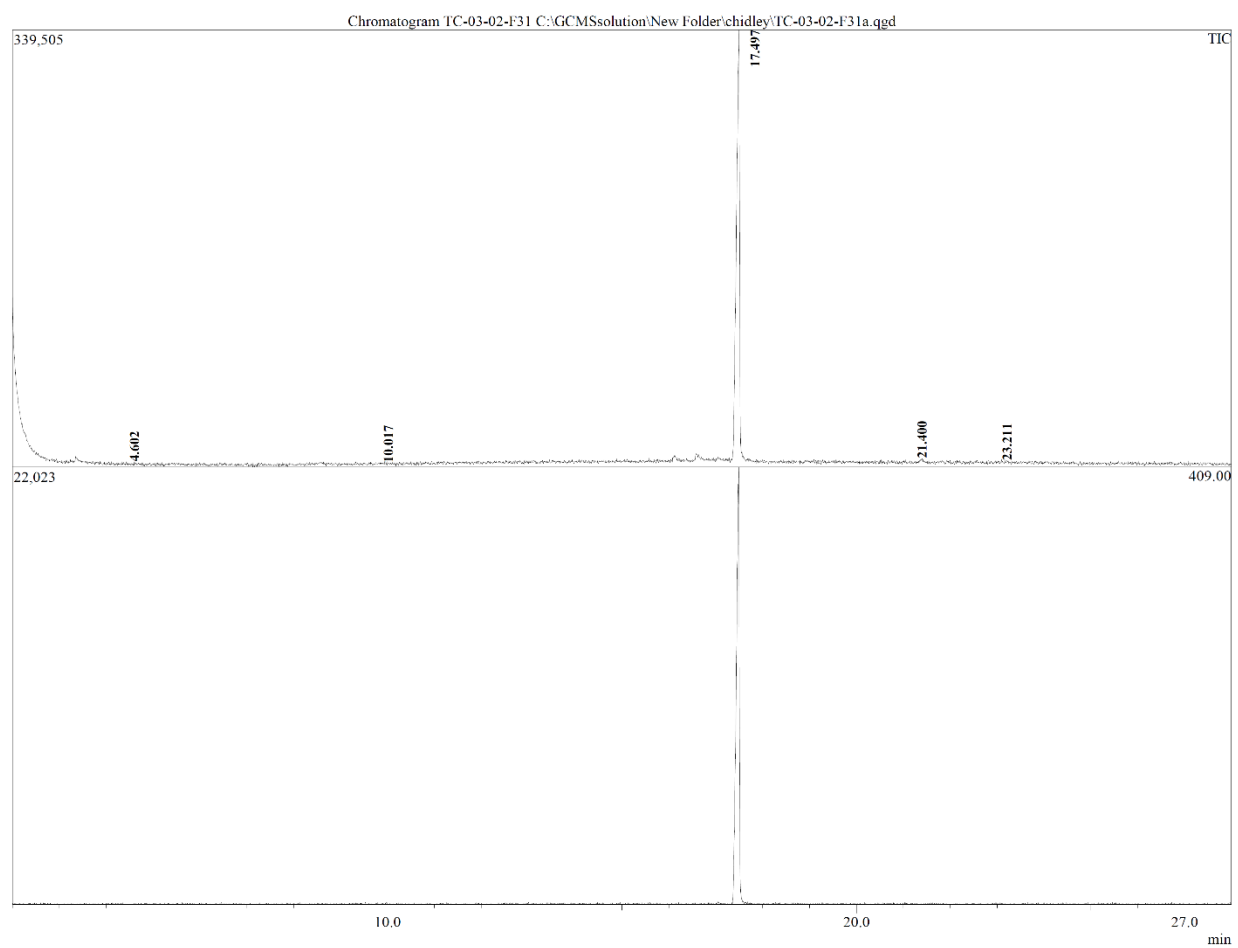

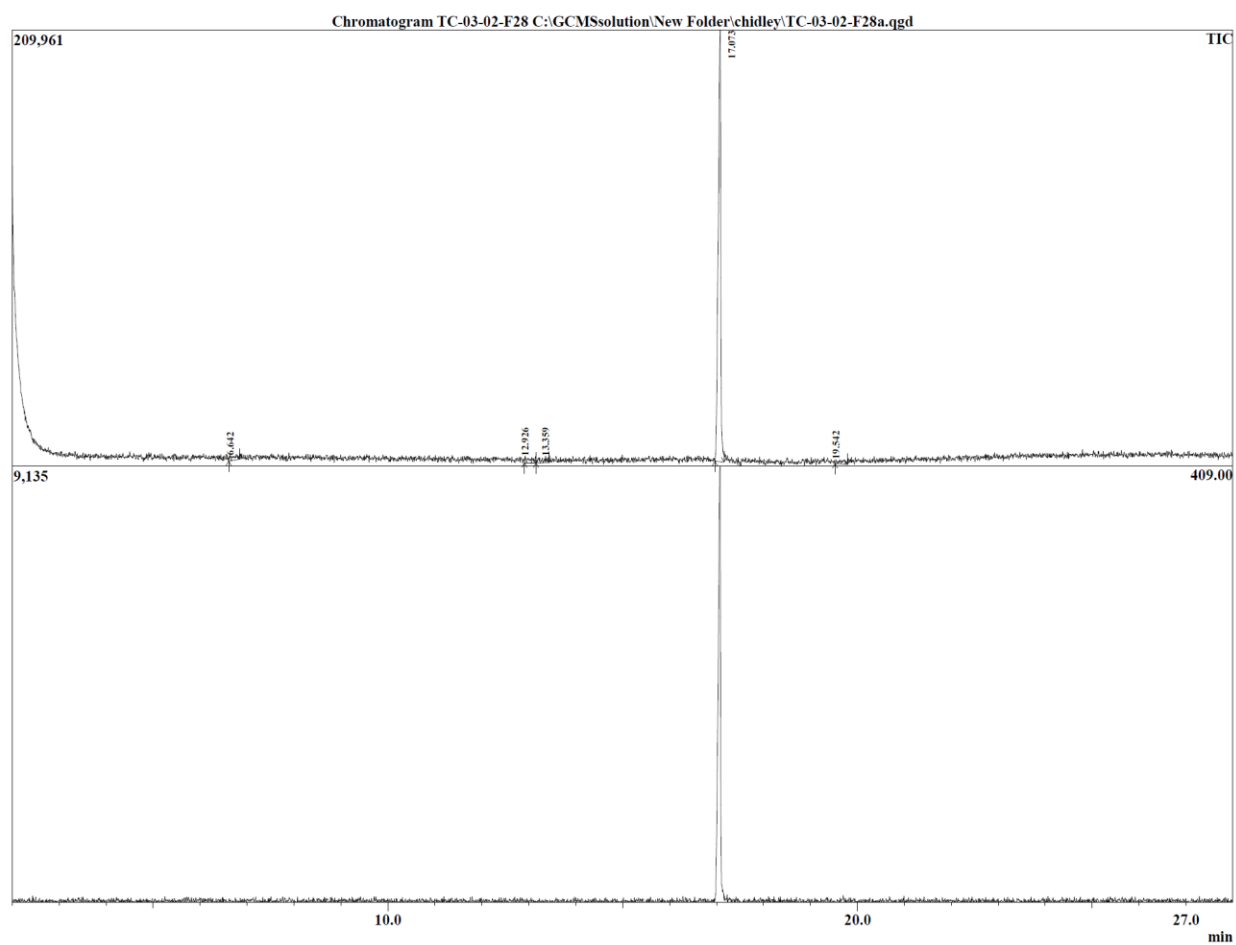
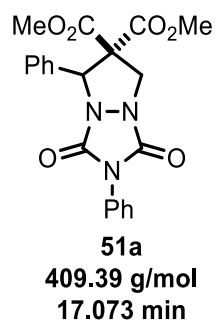

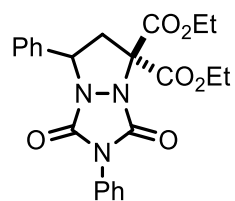
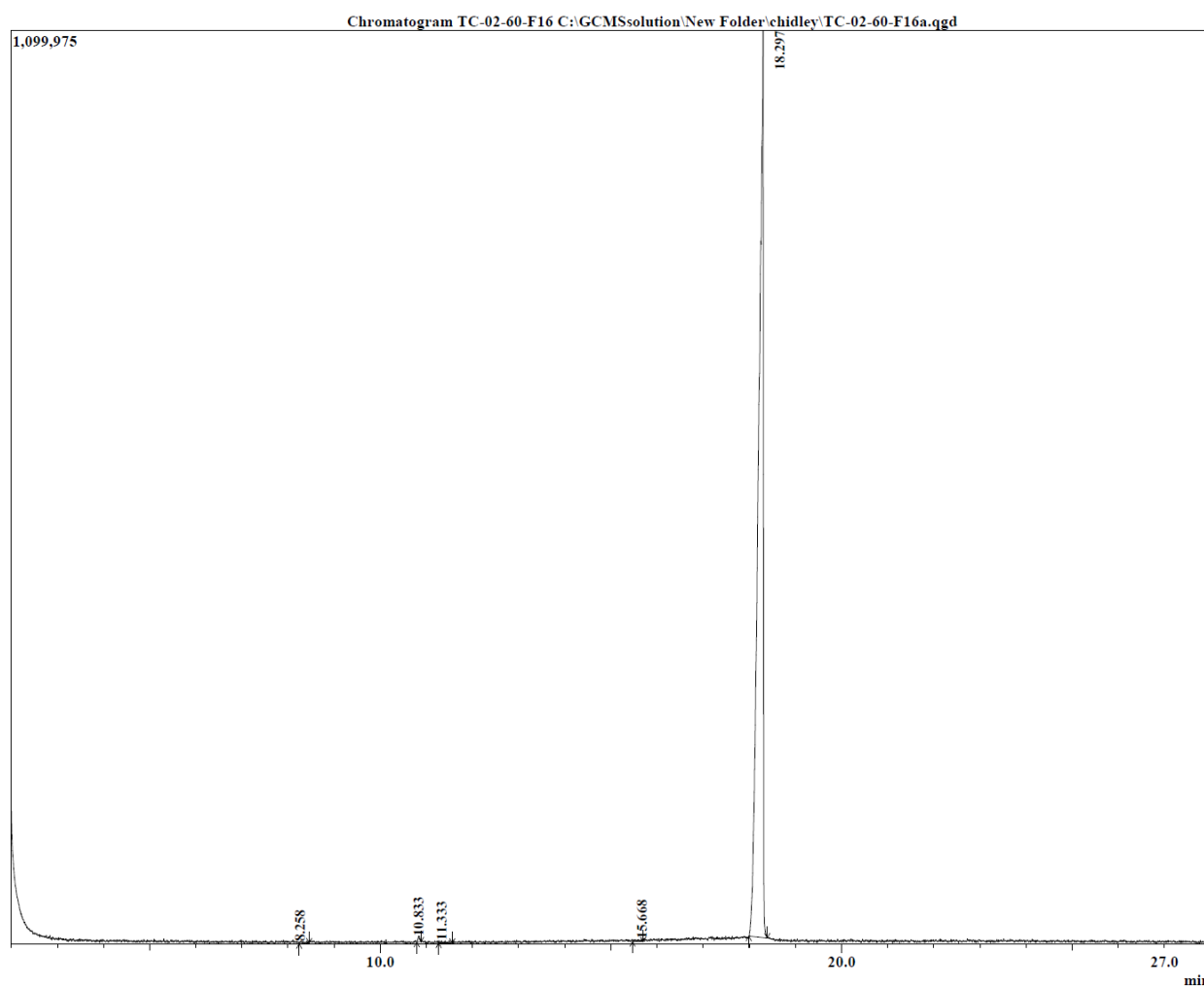
**50b****437.45 g/mol****18.297 min**

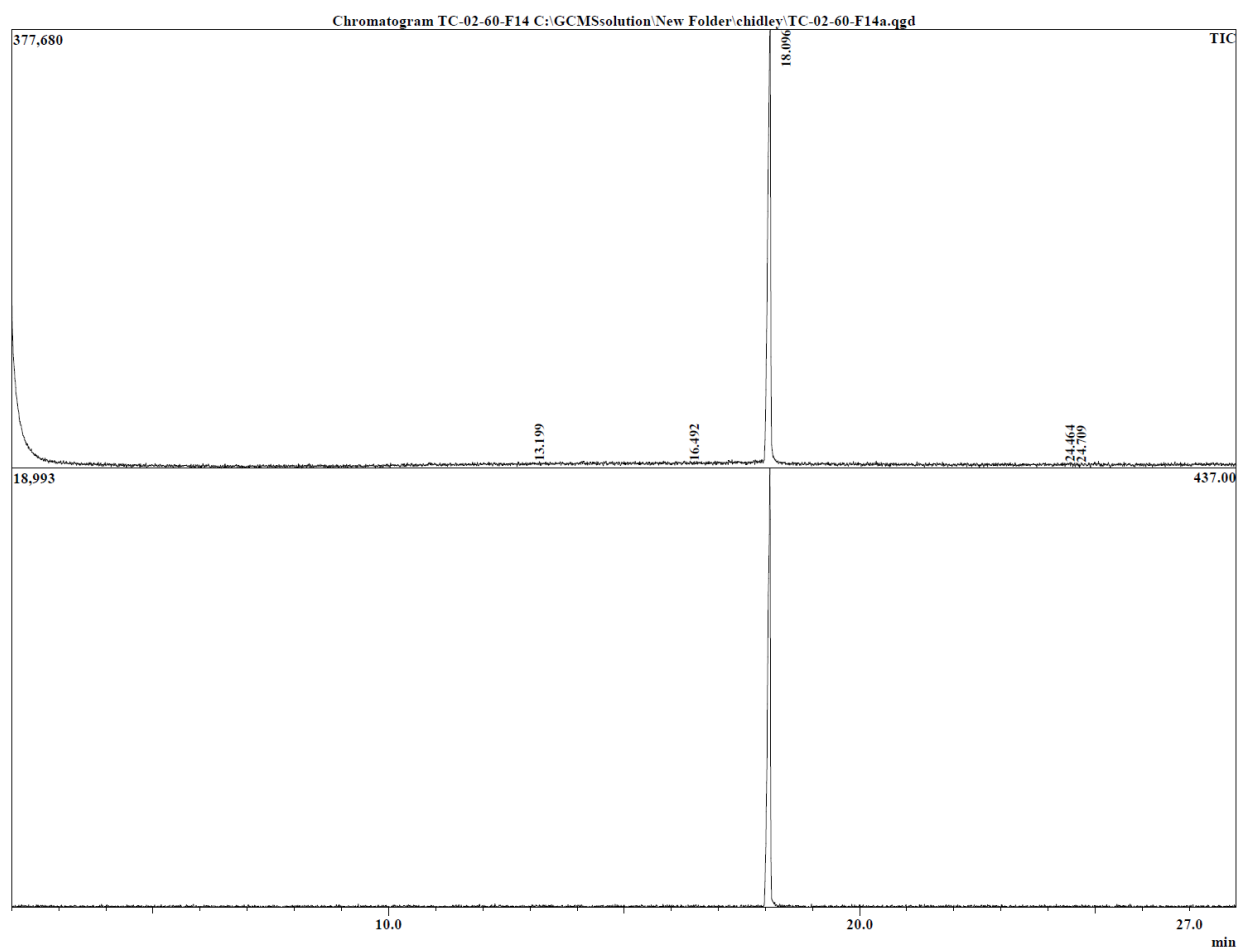
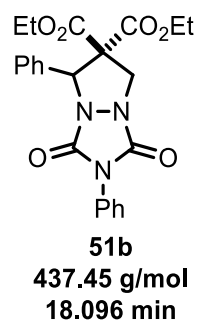

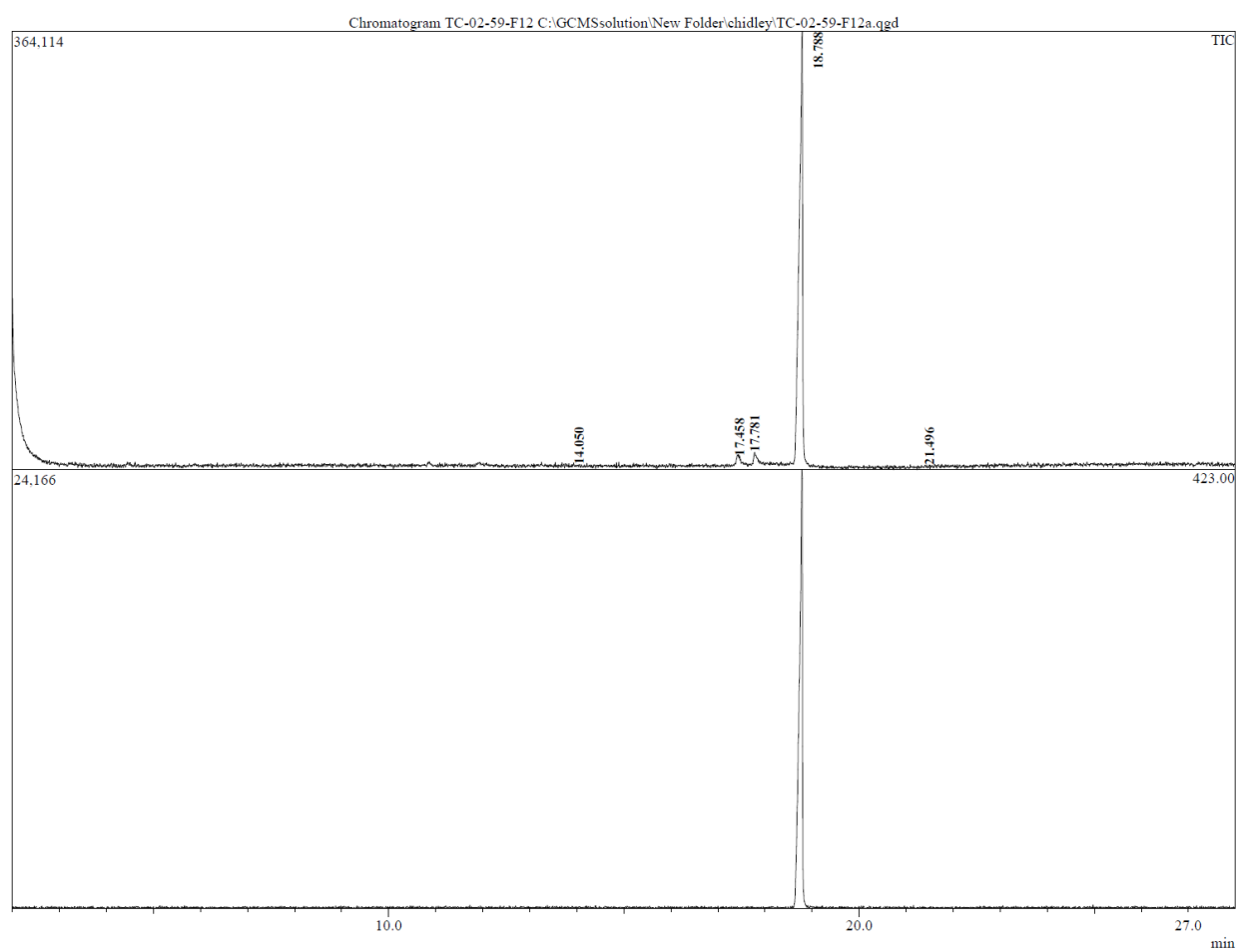
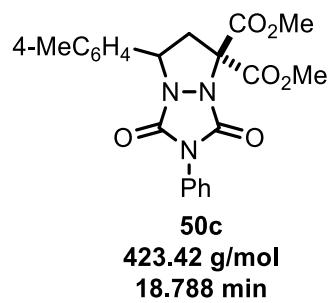

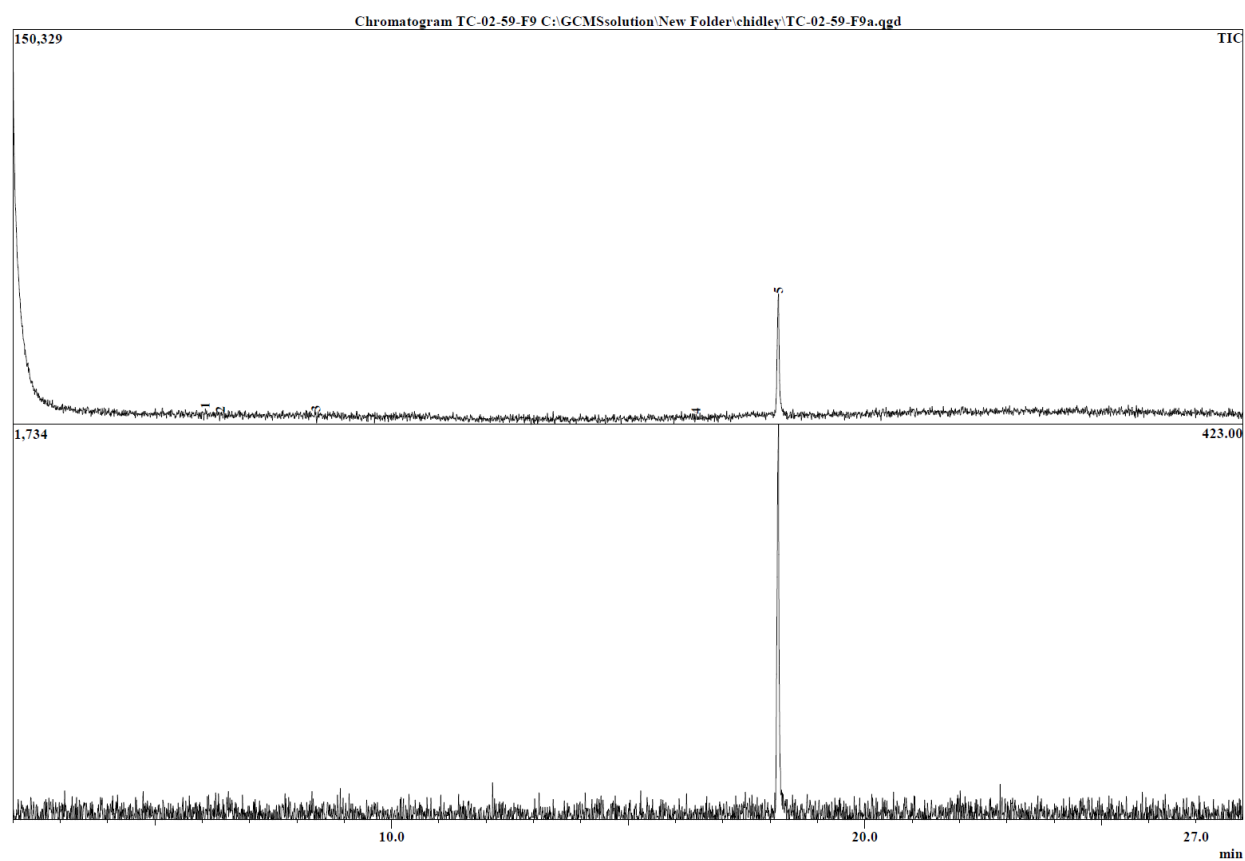
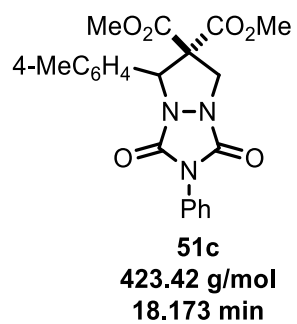

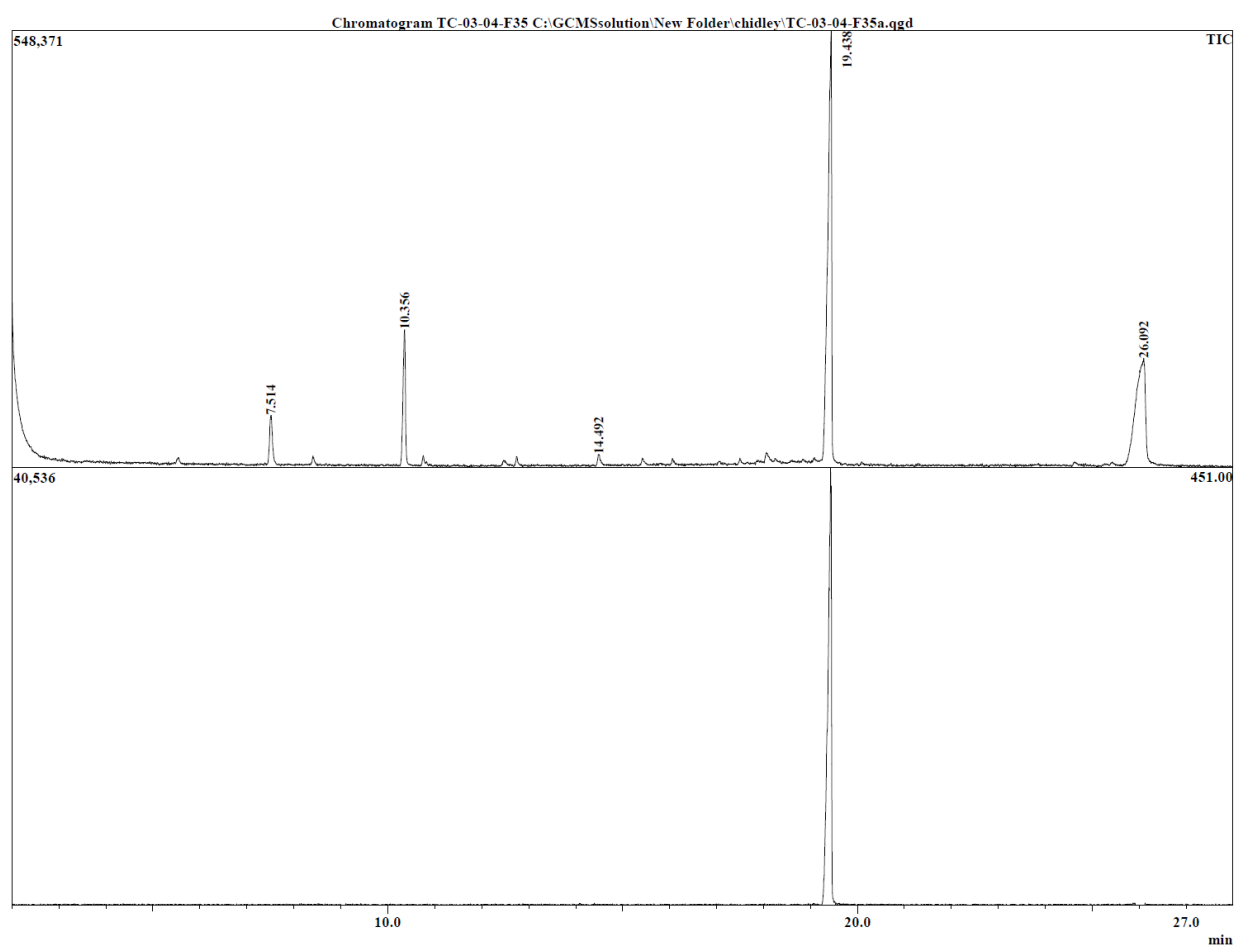
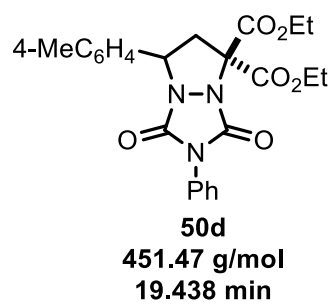

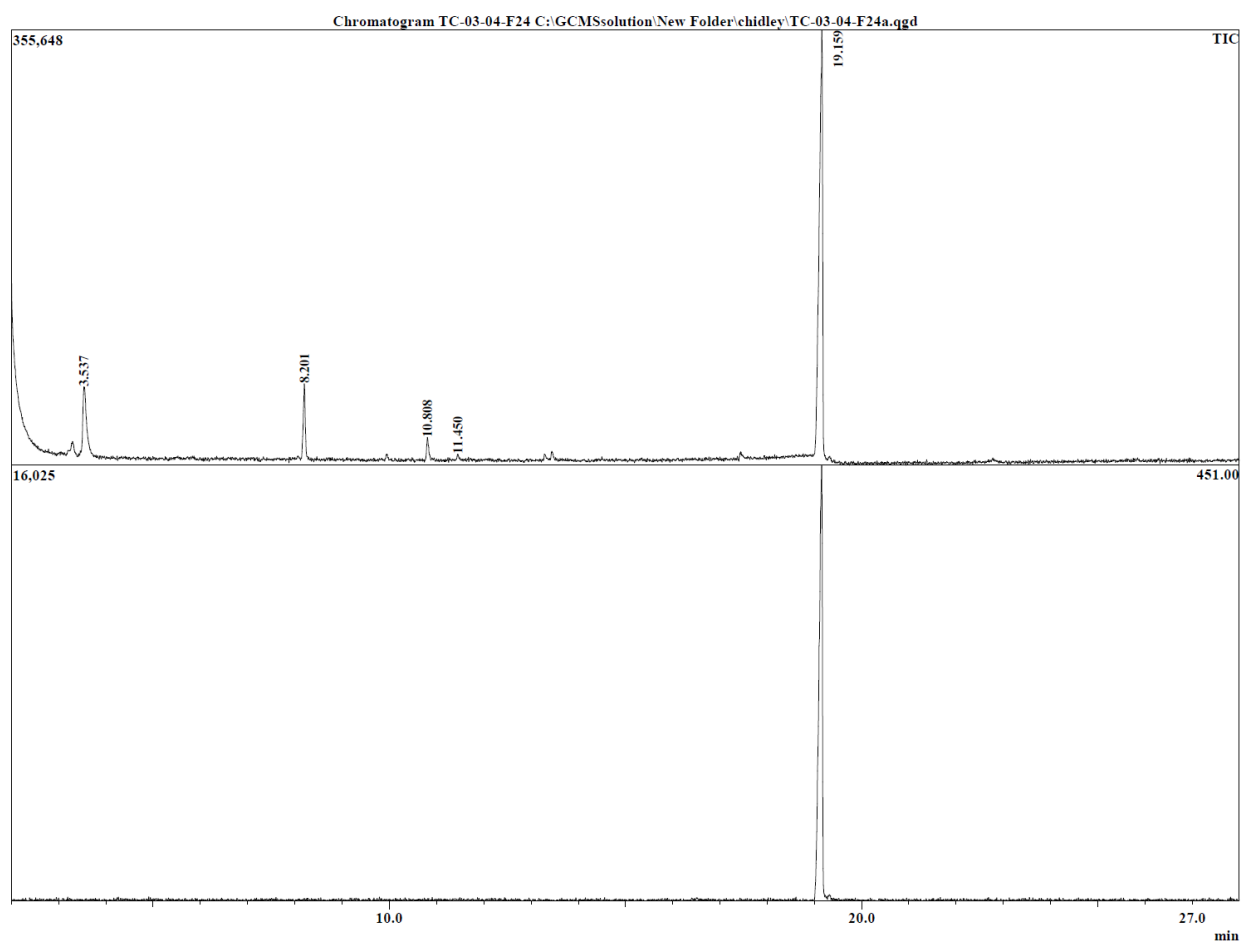
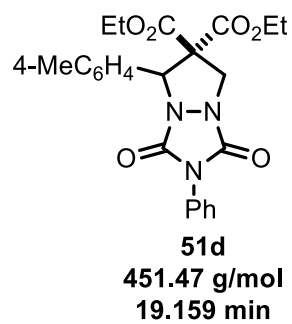

Cross-Over Experiment #3 Standards

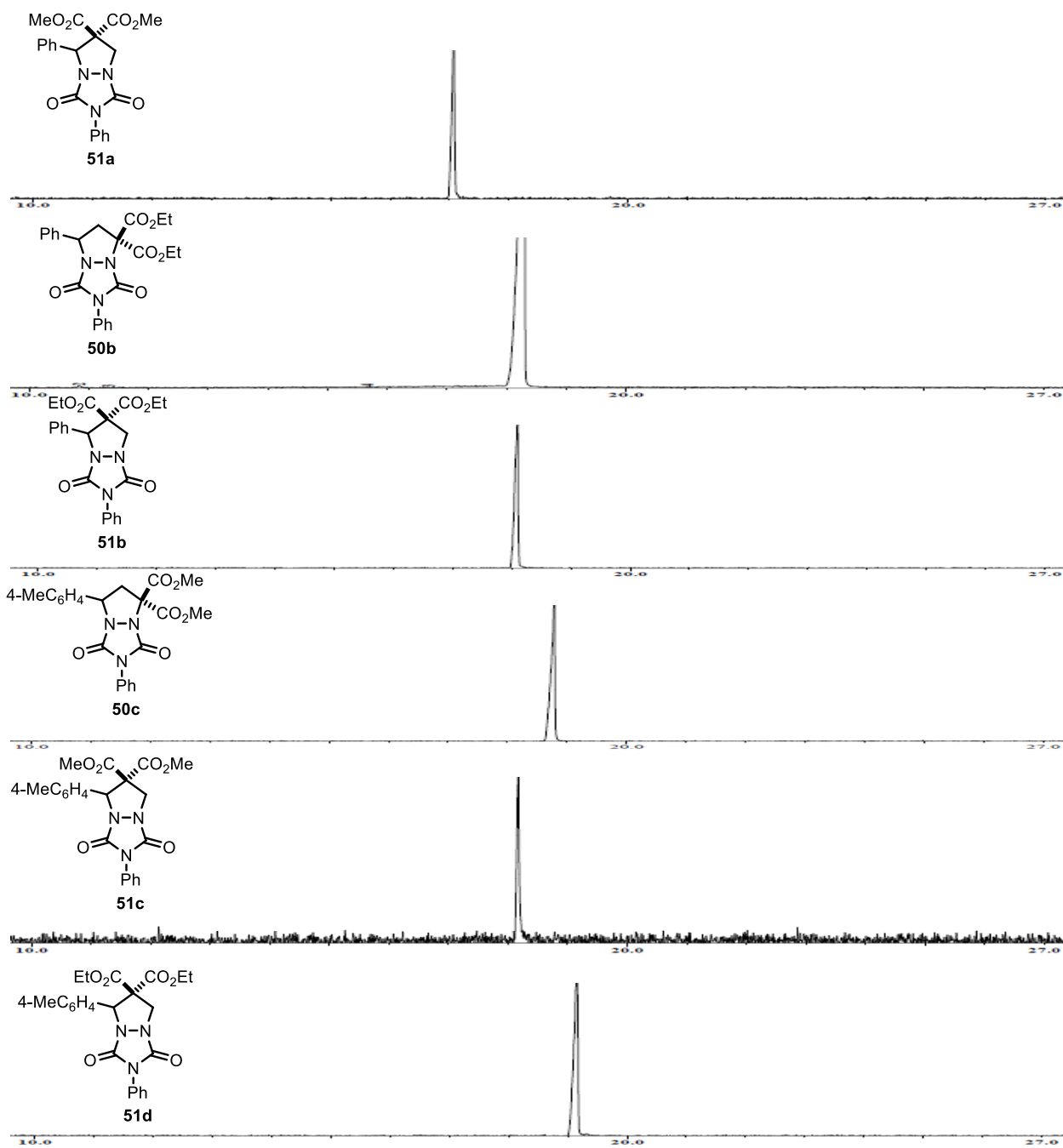

Cross-Over Experiment #3 Reversed (Run #1)

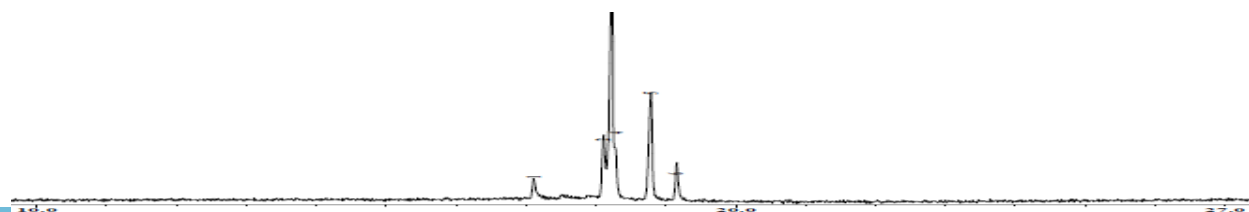

Cross-Over Experiment #3 Reversed (Run #1)

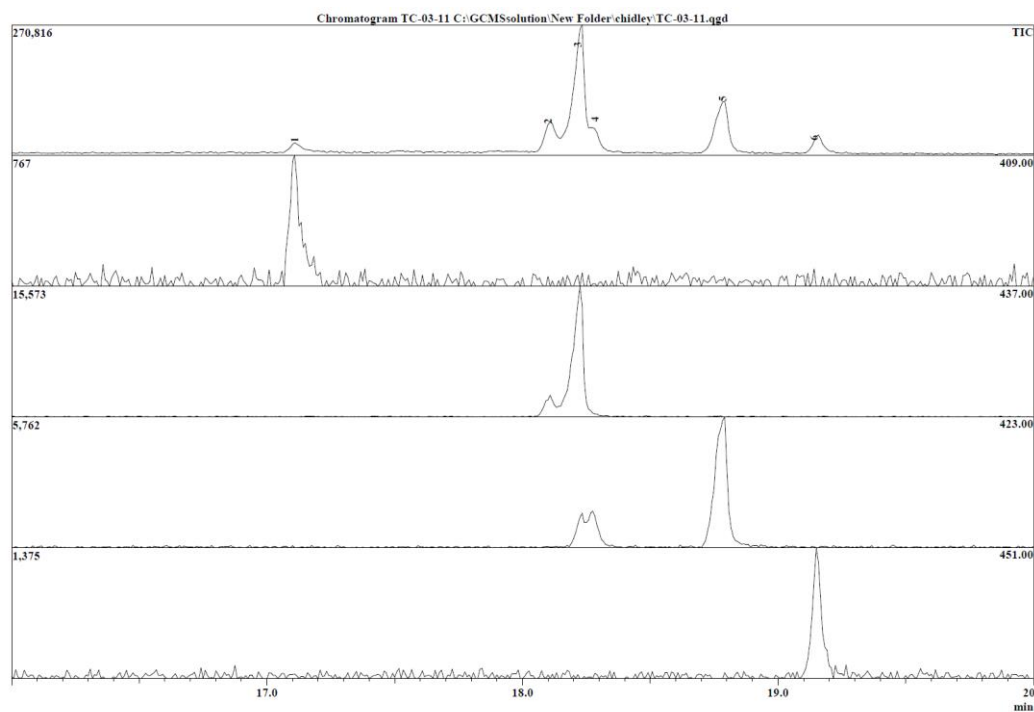
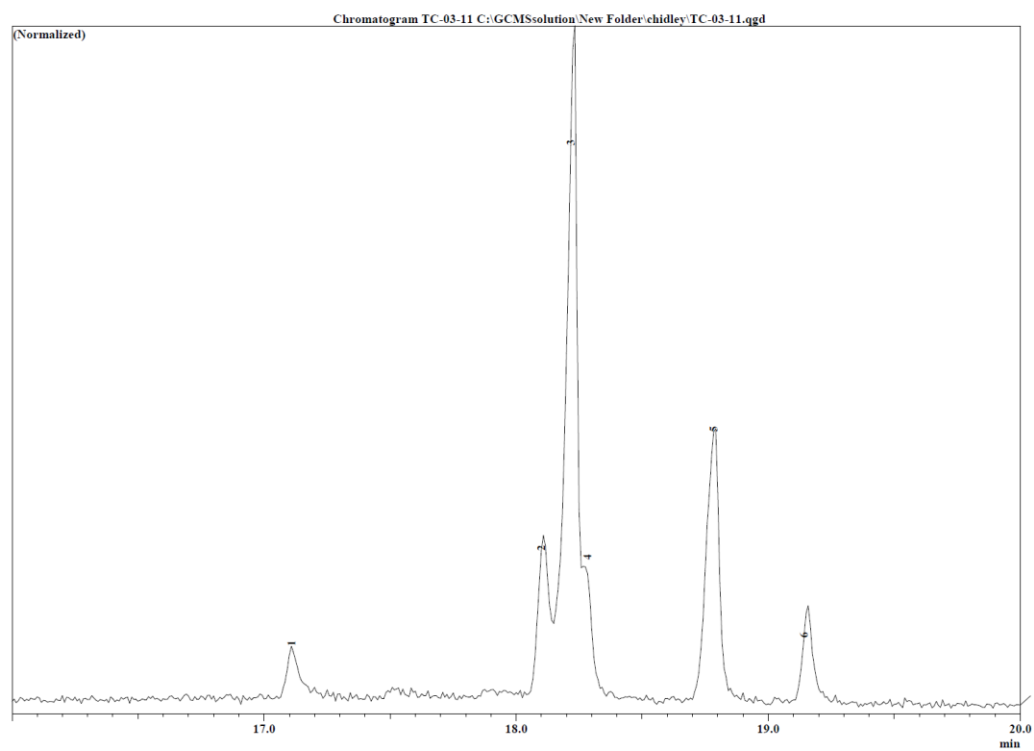

Cross-Over Experiment #3 Reversed (Run #1)

Peak #1

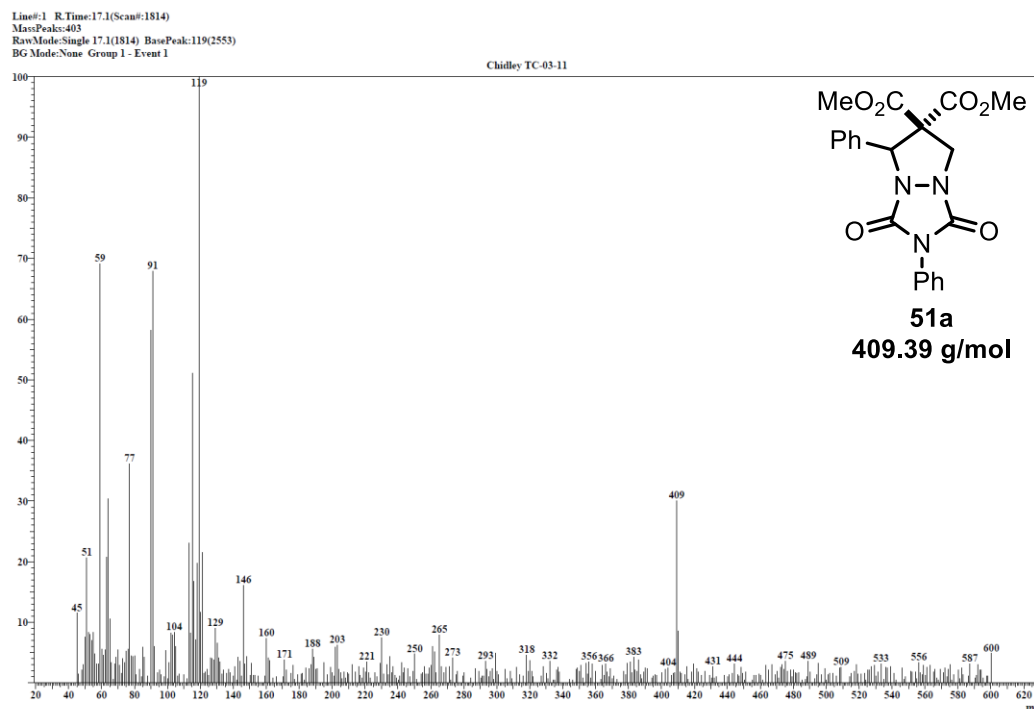

Peak #2

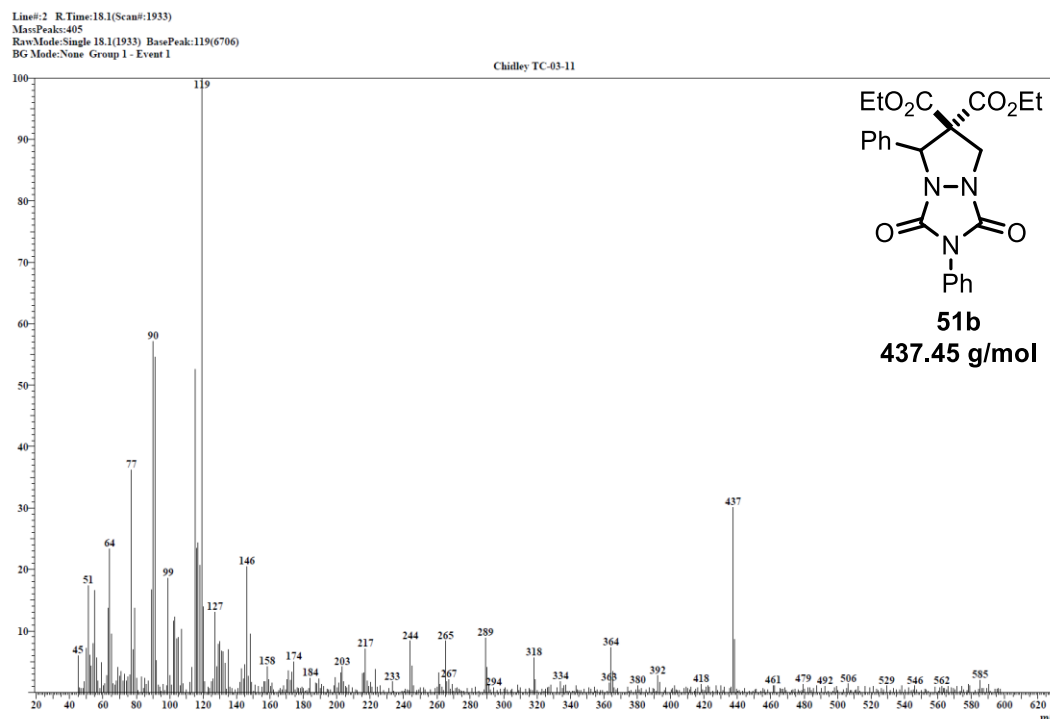

Peak #3

Line#3 RTime:18.2(Scan#:1947)
 MassPeaks:425
 RawMode:Single 18.2(1947) BasePeak:245(25497)
 BG Mode:None Group 1 - Event 1

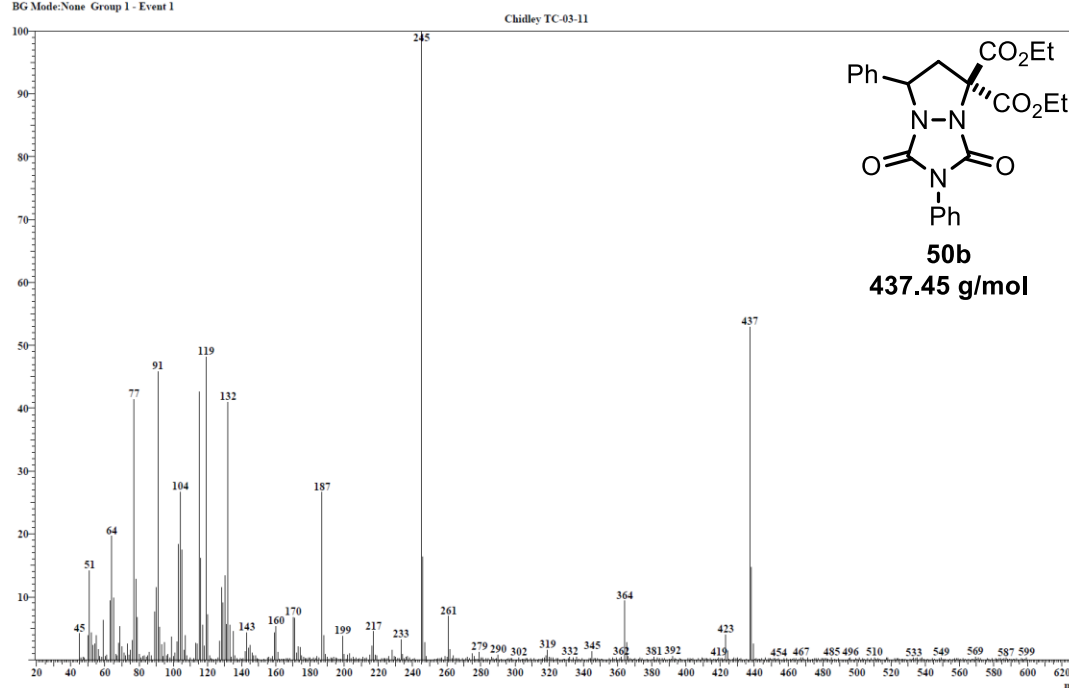

Peak #4

Line#4 RTime:18.3(Scan#:1955)
 MassPeaks:416
 RawMode:Single 18.3(1955) BasePeak:104(4281)
 BG Mode:None Group 1 - Event 1

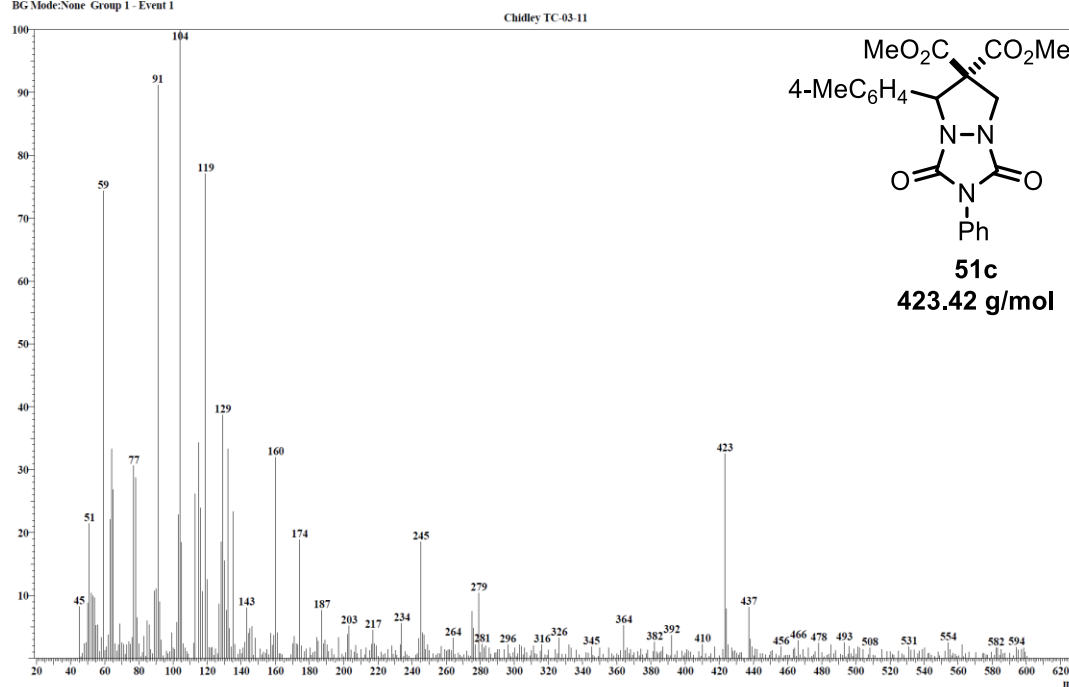

Peak #5

Line#:5 R.Time:18.8(Scan#:2015)
 MassPeaks:400
 RawMode:Single 18.8(2015) BasePeak:59(10440)
 BG Mode:None Group 1 - Event 1

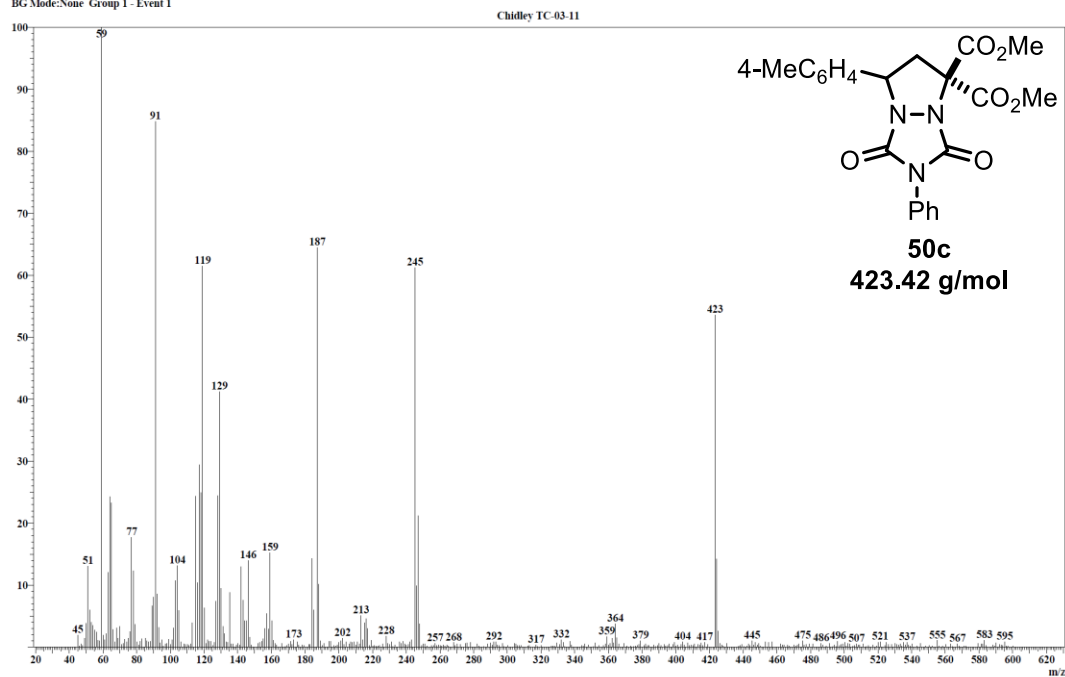

Peak #6

Line#:6 R.Time:19.1(Scan#:2058)
 MassPeaks:400
 RawMode:Single 19.1(2058) BasePeak:104(2207)
 BG Mode:None Group 1 - Event 1

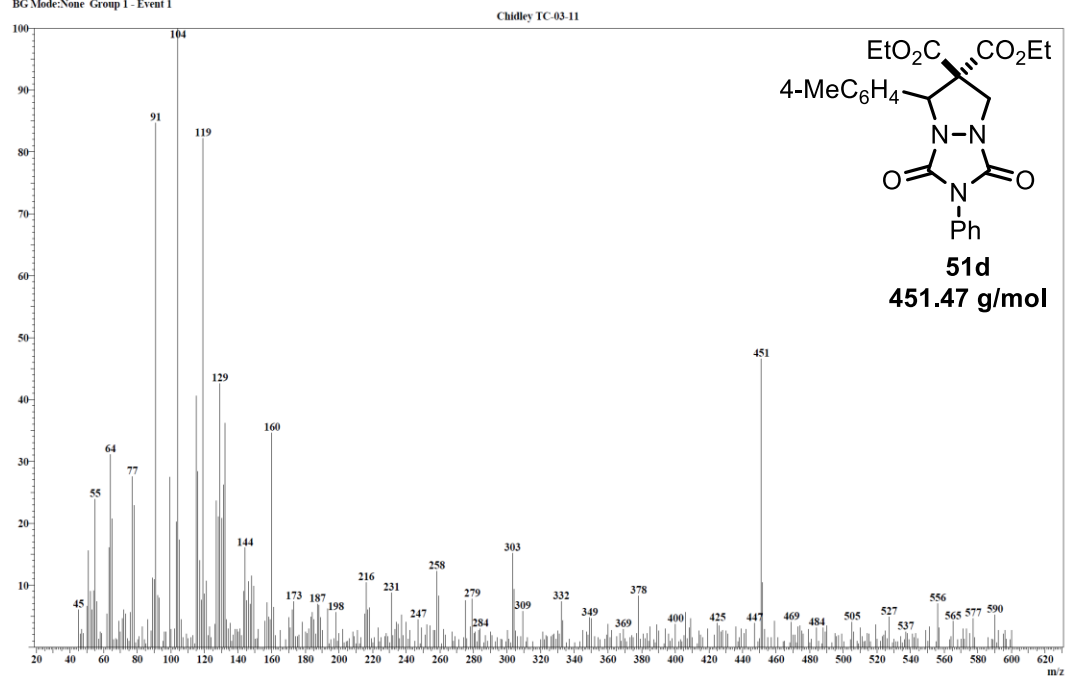

Cross-Over Experiment #3 Reversed (Run #2)

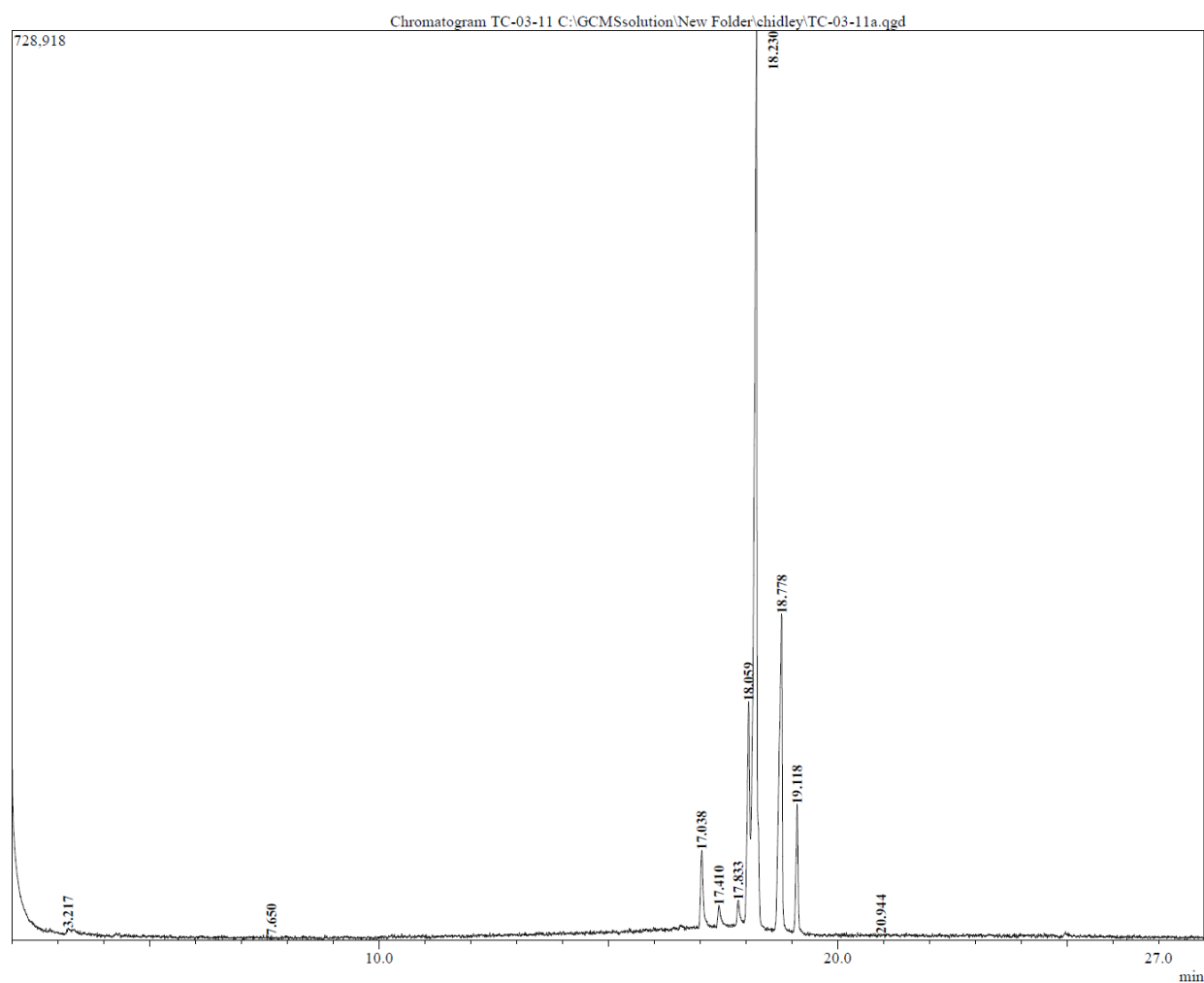

Peak Report TIC										
Peak#	R.Time	I.Time	F.Time	Area	Area%	Height	Height%	A/H	Mark	Name
1	3.217	3.175	3.292	15316	0.26	3900	0.29	3.92		
2	7.650	7.633	7.883	16625	0.28	3303	0.24	5.03		
3	17.038	16.975	17.183	252627	4.32	61958	4.55	4.07	V	
4	17.410	17.333	17.517	64330	1.10	16461	1.21	3.90		
5	17.833	17.775	17.908	76891	1.31	19783	1.45	3.88		
6	18.059	17.908	18.100	712107	12.17	179331	13.17	3.97	V	
7	18.230	18.100	18.358	3158119	53.96	717663	52.72	4.40	V	
8	18.778	18.625	18.900	1218120	20.81	253772	18.64	4.80		
9	19.118	19.033	19.200	320044	5.47	102002	7.49	3.13		
10	20.944	20.875	21.033	18385	0.31	3106	0.23	5.91	V	
				5852564	100.00	1361279	100.00			

Cross-Over Experiment #3 Reversed (Run #3)

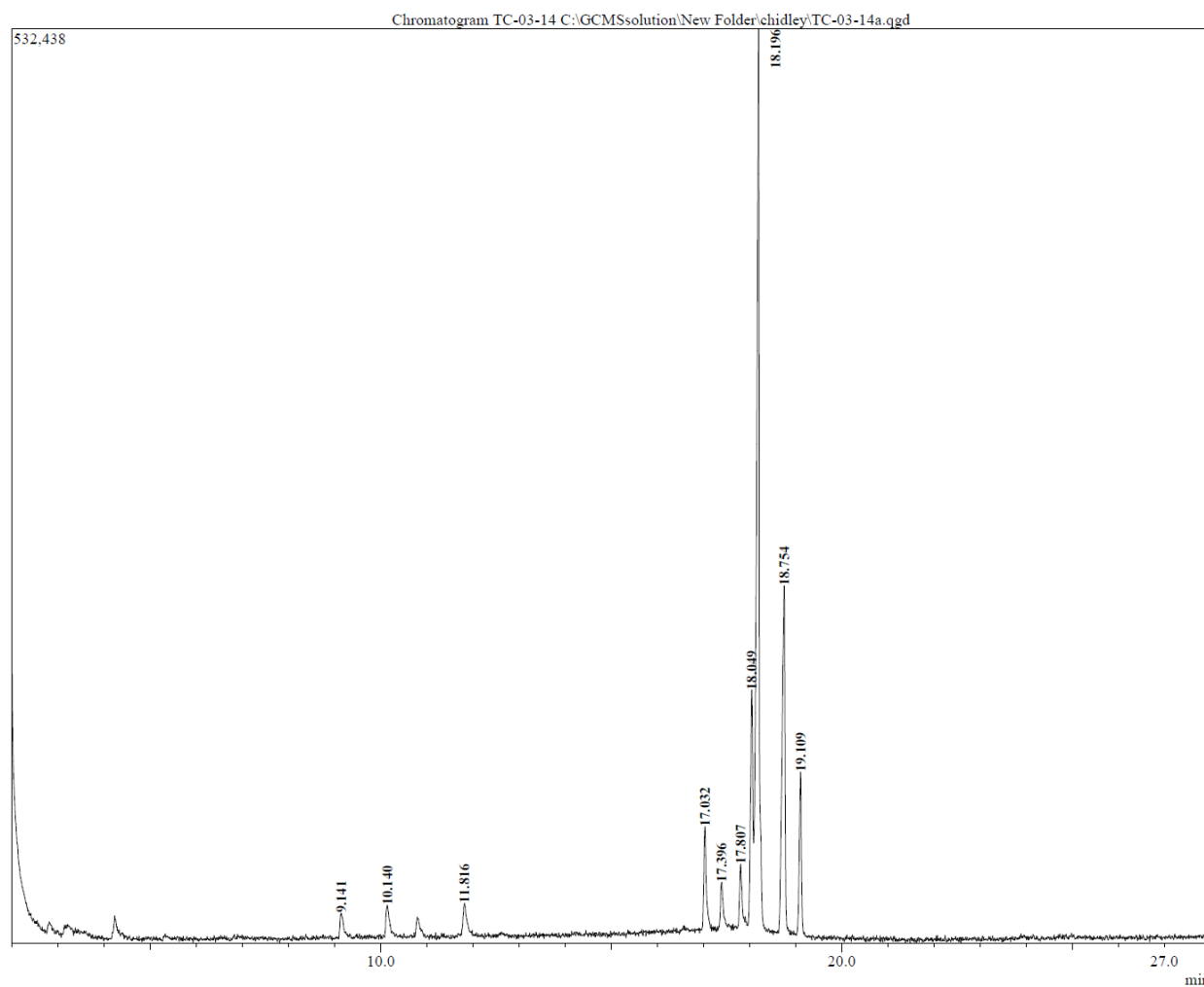

Peak Report TIC										
Peak#	R.Time	I.Time	F.Time	Area	Area%	Height	Height%	A/H	Mark	Name
1	9.141	9.083	9.217	60476	1.33	13443	1.19	4.49		
2	10.140	10.083	10.225	82063	1.80	17612	1.55	4.65		
3	11.816	11.758	11.925	70488	1.55	15649	1.38	4.50		
4	17.032	16.958	17.158	232208	5.09	60274	5.32	3.85		
5	17.396	17.292	17.525	137326	3.01	28432	2.51	4.82		
6	17.807	17.758	17.925	157131	3.45	38219	3.37	4.11	V	
7	18.049	17.925	18.092	528048	11.58	139428	12.30	3.78	V	
8	18.196	18.092	18.325	2087367	45.78	524150	46.24	3.98	V	
9	18.754	18.633	18.825	909174	19.94	202577	17.87	4.48		
10	19.109	19.033	19.183	295777	6.49	93759	8.27	3.15		
				4560058	100.00	1133543	100.00			

Curriculum Vitae

Tristan Chidley

Education

M. Sc. Chemistry 2013 - 2015

The University of Western Ontario

Supervisor: Brian L. Pagenkopf

B. Sc. Biochemistry 2001 - 2005

University of Guelph

Graduation with Honours

Related Work Experience

Graduate Research Assistant 2013 - 2015

The University of Western Ontario

Supervisor: Brian L. Pagenkopf

Graduate Teaching Assistant 2013 - 2015

The University of Western Ontario

CHEM 2223b & CHEM 3373

Summary of Course Work

Course Title	Course Code	Instructor	Grade	Credit
Mechanistic Organic Chemistry	9553	Dr. Hudson	92	0.50
Heterocycles	9823	Dr. Kerr	93	0.25
Total Synthesis	9563	Dr. Kerr	91	0.25